



# European Technical Assessment **ETA 22/0867** of 27/12/2022

## I General Part

<b>Technical Assessment Body issuing the ETA</b>	Eurofins Expert Services Oy
<b>Trade name of the construction product</b>	EJOT Purlin Anchors
<b>Product family to which the construction product belongs</b>	Three-dimensional nailing plates
<b>Manufacturer</b>	<b>EJOT Baubefestigungen GmbH</b> In der Stockwiese 35 D-57334 Bad Laasphe Germany  <a href="http://www.ejot.com">www.ejot.com</a>
<b>Manufacturing plant</b>	EJOT Plant 52
<b>This European Technical Assessment contains</b>	21 pages including 2 Annexes which form an integral part of this assessment
<b>This European Technical Assessment is issued in accordance with regulation (EU) No 305/2011, on the basis of</b>	EAD 130186-00-0603 for Three-dimensional nailing plates

Translations of this European Technical Assessment in other languages shall fully correspond to the original issued document and should be identified as such.

Communication of this European Technical Assessment, including transmission by electronic means, shall be in full excepted the confidential Annex(es) referred to above. However, partial reproduction may be made, with the written consent of the issuing Technical Assessment Body. Any partial reproduction has to be identified as such.

This European Technical Assessment may be withdrawn by the issuing Technical Assessment Body, pursuant to information by the Commission according to Article 25 Paragraph 3 of Regulation (EU) No 305/2011.

## II Specific Part

### 1 Technical description of the product

EJOT Purlin Anchors type 170 R (72101), 170 L (72102), 210 R (72103), 210 L (72104), 250 R (72105), 250 L (72106), 290 R (72107), 290 L (72108), 330 R (72109), 330 L (72110), 370 R (72111) and 370 L (72112) are one piece, non-welded, face-fixed purlin anchors to be used in timber to timber connections. The type of the connector and the typical use of the purlin anchors are shown in Figure 1. The purlin anchors are connected to the timber members by anchor nails or screws.

EJOT Purlin Anchors are made from pre-galvanized steel DX51D+Z275 or S250GD+275Z according to EN 10346:2015 with minimum yield strength  $R_{eL}$  or  $R_{p0.2}$  of 250 N/mm<sup>2</sup> and minimum tensile strength  $R_m$  of 330 N/mm<sup>2</sup>. Dimensions and hole position of the connectors are shown in Annex 1. The purlin anchors are made from steel with tolerances according to EN 10143.

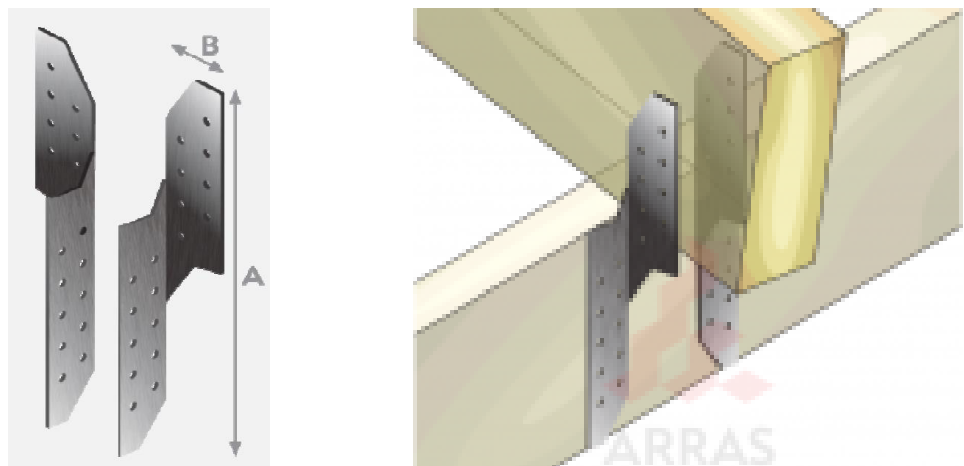

**Figure 1.** Types of right and left hand purlin anchors and the typical use of connectors.

### 2 Specification of the intended uses in accordance with the applicable EAD

#### 2.1 Intended uses

The purlin anchors are intended for use in making connections in load bearing timber structures, as a connection between a beam and a purlin, where requirements for mechanical resistance and stability and safety in use shall fulfilled.

Two same sizes of connectors with the same number of fasteners are always used symmetrically at both sides of the purlin (see Figure 1).

The EJOT Purlin Anchors are used as a purlin to beam or purlin to column connection subjected to a tension load parallel to the length direction of the connector (see Annex 2). The Purlin Anchors are not assumed to have any load-carrying capacity for lateral forces perpendicular to the length direction of the connector.

The static and kinematic behaviour of the timber members or the supports shall be as described in Annex 2. The wood members can be solid timber according to EN 14081, glued laminated timber according to EN 14081 or LVL (Laminated Veneer Lumber) according to EN 14374. The characteristic density  $\rho_k$  of the timber shall not be greater than 500 kg/m<sup>3</sup>. Timber parts are not pre-bored for the fasteners. Nails and screws shall be inserted perpendicular to the grain direction of wood. Purlin anchors shall not be fixed to the edge face of a LVL member.

The EJOT Purlin Anchors shall be fixed by anchor nails or screws according to EN 14592 (see Figure 2). The diameter of the anchor nails  $d$  shall be 4,0 mm and the profiled length shall be at least 24 mm. The diameter of the smooth part of the anchor screws  $d$  shall be 4,5...5,0 mm and the inner diameter of the threaded part  $d_s \geq 3,0$  mm. The length of the threaded part of the screw shall be at least  $6d$ .



**Figure 2.** Fasteners: a) anchor nail and b) anchor screw.

The design of the connections shall be in accordance with Eurocode 5. The timber members shall have a thickness which is larger than the penetration depth of fasteners into members.

The purlin anchors are intended for use for connections subject to static and quasi-static loading.

The purlin anchors are for use in timber structures subject to the dry, internal conditions defined by the service classes 1 and 2 of EN 1995-1-1.

## 2.2 Working life

The provisions made in this European Technical Assessment are based on an assumed intended working life of the purlin anchors of 50 years.<sup>1</sup>

## 2.3 Identification

EJOT Purlin Anchors are identified by product labels that are marked with "EJOT" logo.

---

<sup>1</sup> This means that it is expected that when this working life has elapsed, the real working life may be, in normal use conditions, considerably longer without major degradation affecting the essential requirements of the works. The indications given as to the working life of a product cannot be interpreted as a guarantee given by the producer or the assessment body. They should only be regarded as a means for the specifiers to choose the appropriate criteria for products in relation to the expected, economically reasonable working life of the works.

### 3 Performance of the product and references to the methods used for its assessment

**Table 1.** Handling of basic requirements for construction works

Basic requirement and essential characteristics	Performance
<b>BWR 1. Mechanical resistance and stability</b>	
Joint strength	Clause 3.1
Joint stiffness	No performance assessed
Joint ductility	No performance assessed
Resistance to seismic actions	No performance assessed
Resistance to corrosion and deterioration	Clause 3.1
<b>BWR 2. Safety in case of fire</b>	
Reaction to fire	Clause 3.2
Resistance to fire	No performance assessed

#### 3.1 Mechanical resistance and stability, BWR 1

##### 3.1.1 Joint strength

Characteristic resistance values of EJOT Purlin Anchors are given in Annex 2.

##### 3.1.2 Resistance to corrosion and deterioration

EJOT Purlin Anchors have been assessed as having satisfactory durability and serviceability when used in timber structures when the timber species (including timbers preserved with organic solvent, boron diffusion and related preservatives) described in Eurocode 5 (EN 1995-1-1: 2004) are used and the structures are subject to the dry, internal conditions defined by service classes 1 and 2.

#### 3.2 Safety in case of fire, BWR 2

##### 3.2.1 Reaction to fire

EJOT Purlin Anchors are made of materials classified to have reaction to fire class A1 according to EN 13501-1.

**4 Assessment and verification of constancy of performance (hereinafter AVCP) system applied, with reference to its legal base**

According to the Decision 97/638/EC of the European Commission<sup>2</sup>, the system of assessment and verification of constancy of performance (see Annex V to the regulation (EU) No 305/2011) is System 2+.

**5 Technical details necessary for the implementation of the AVCP system, as provided for in the applicable EAD**

Technical details necessary for the implementation of the AVCP system are laid down in the control plan deposited at Eurofins Expert Services Oy prior to CE marking.

Issued in Espoo on December 27, 2022<sup>3</sup>  
by Eurofins Expert Services Oy

Katja Vahtikari  
Manager, Construction Certification

Saija Korpijaakko  
Expert, Construction Certification

---

<sup>2</sup> Official Journal of the European Communities L 268 of 1/10/1997

<sup>3</sup> This ETA is a reproduction of ETA 17/0244 issued 23/09/2022.

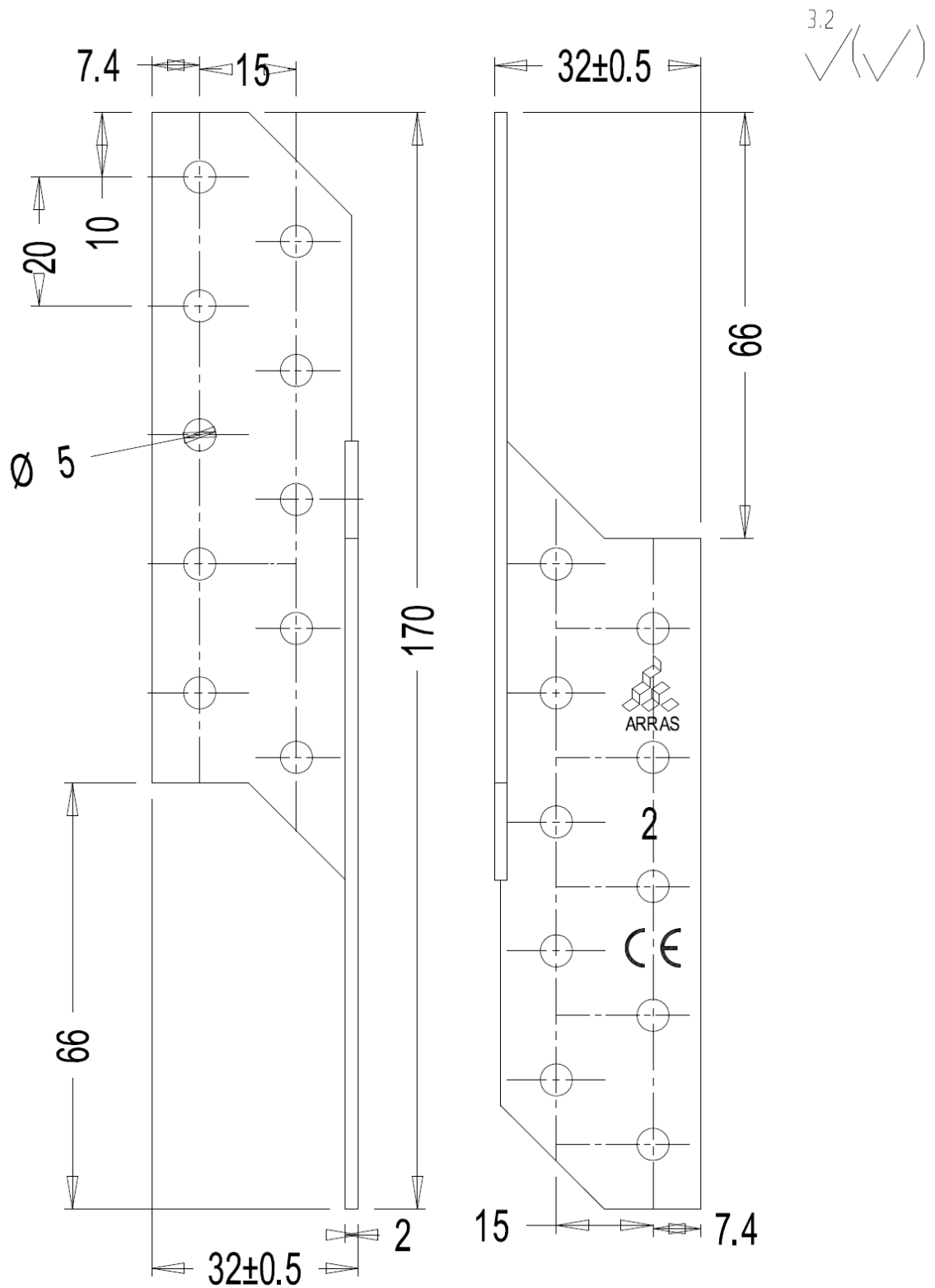

Materjal: HDG DX51D Z275 MAC				Arv: X tk.	Mass:	Mõõt: M1:1	A4
Konstruktor	R.K.		12,09,16	Nimetus: Sarikaankur 170x32x2.0 72101 parem			
Kontrollis							
			Lehti: 1 Lehti: 1	Tähis: KR320		Muudot. -XX	Tootekaart

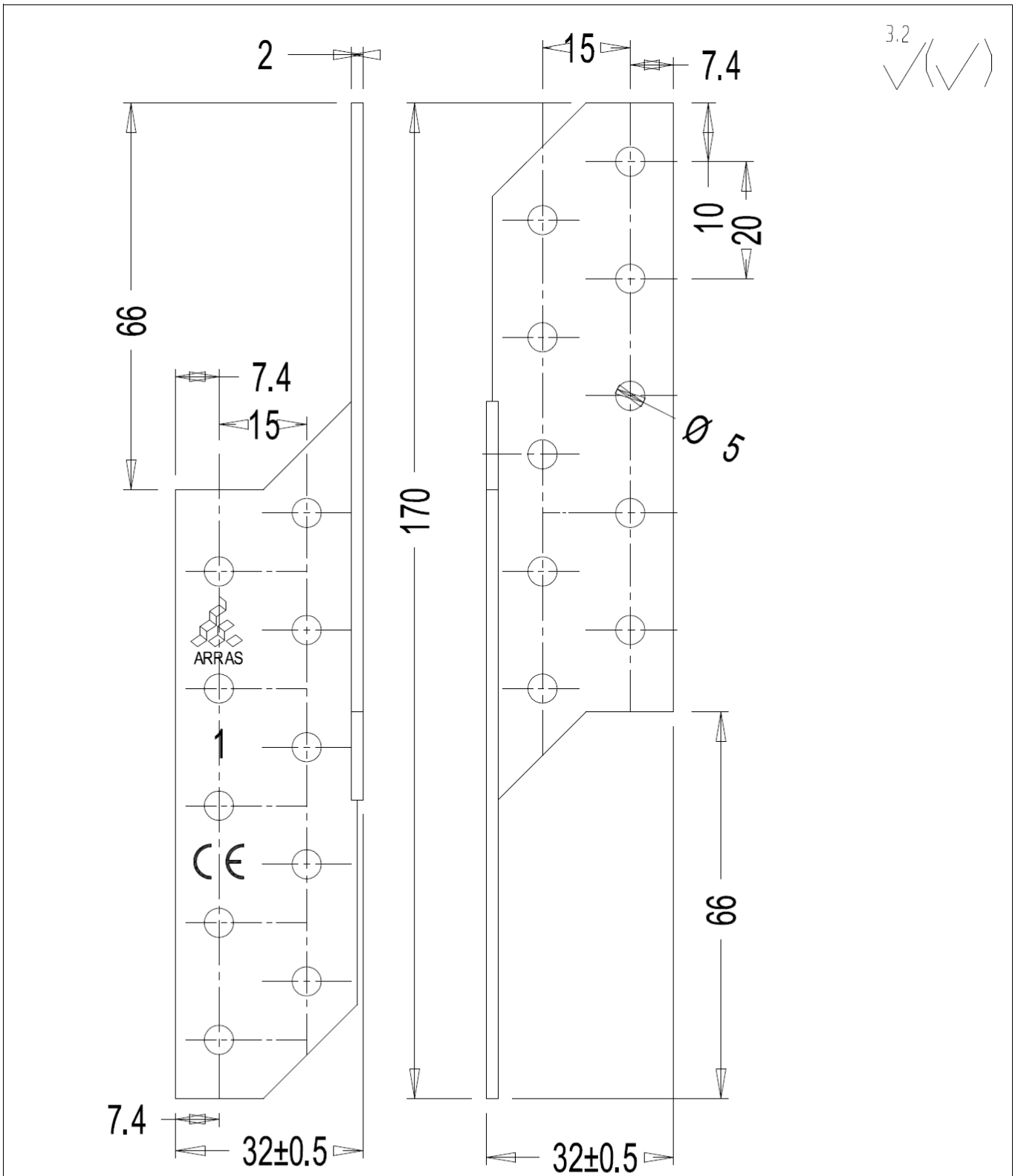

Materjal: HDG DX51D Z275 MAC				Arv: X tk.	Mass:	Mõõt: M1:1	A4
Konstruktor	R.K.	12,09,16	Ninetus: Sarikaankur 170x32x2.0		72102 vasak		
Kontrollis			Tõhis: KR320		Muudat. -XX	Tootekaart	
			Leht: 1				
			Leht: 1				

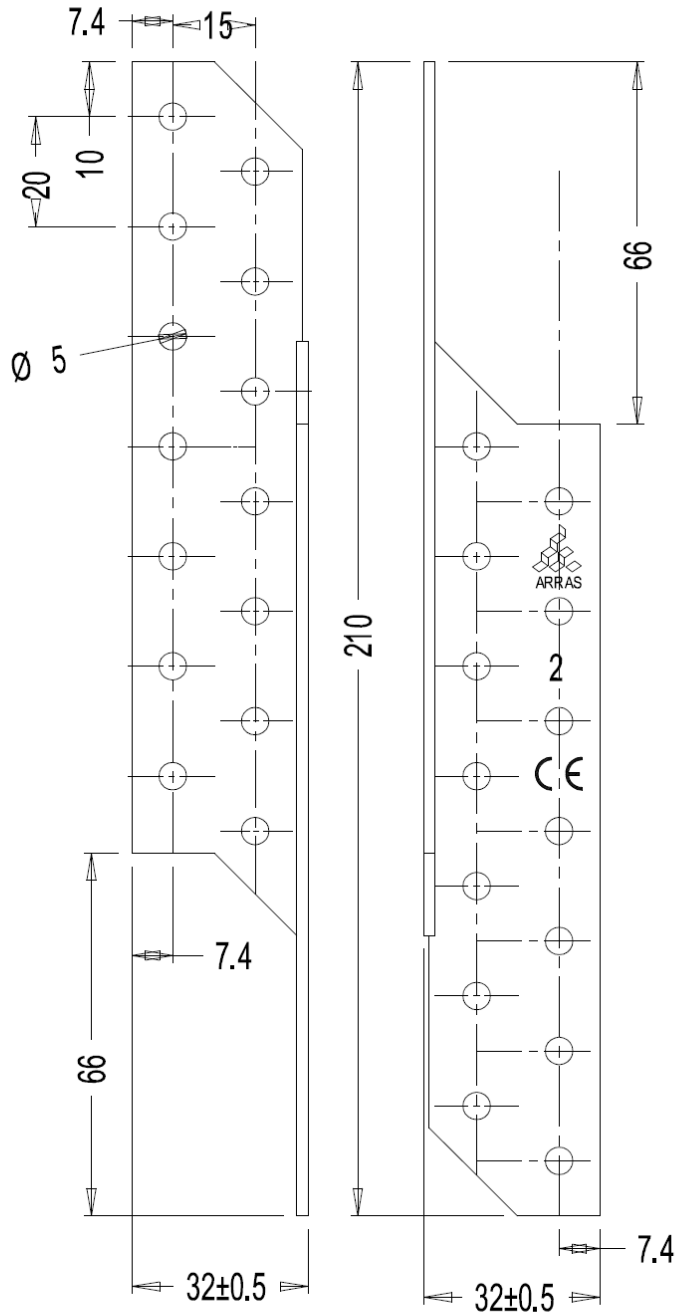

Materjal: HDG DX51D Z275 MAC				Arv: X tk.	Moss:	Mõõt: M1:1	A4
Konstruktor	R.K.		12,09,16	Ninetus Sarikaankur 210x32x2.0 72103 parem			
Kontrollis							
			Leht: 1 Lehti: 1	Tähis: KR320		Muudot. -XX	Tootekaart



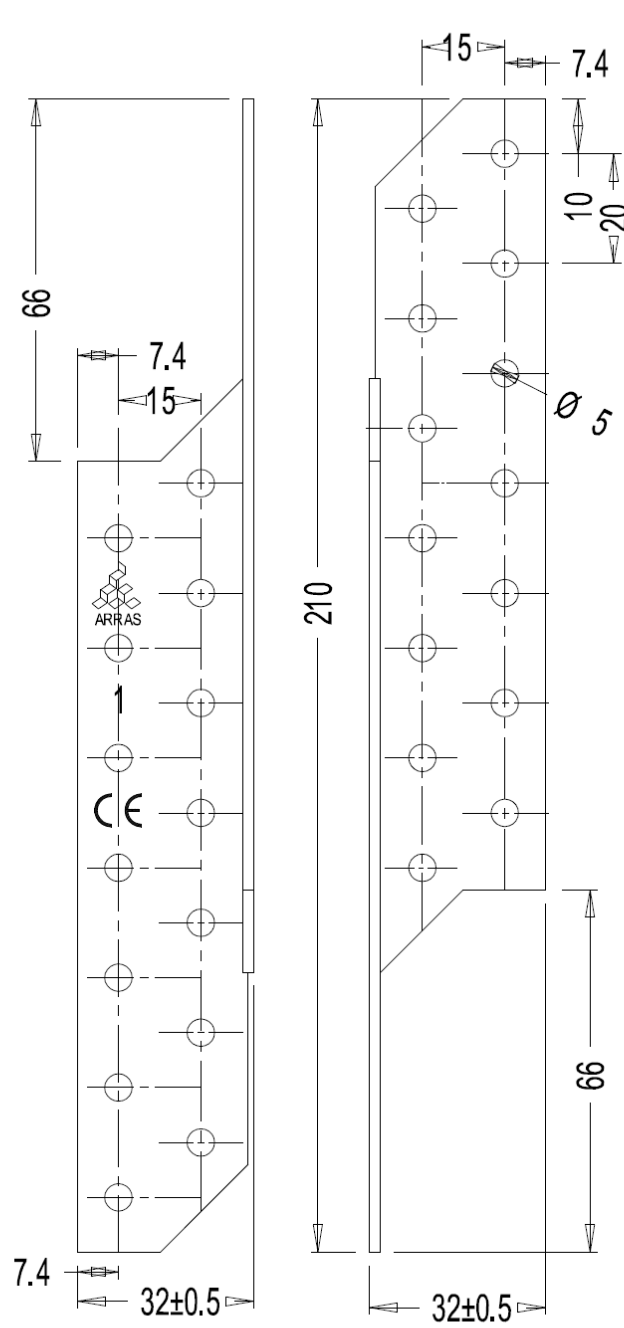

3.2

Materjal: HDG DX51D Z275 MAC.				Arv: X tk.	Moss:	Mõõt: M1:1	A4
Konstruktor	R.K.		12,09,16	Nimetus: Sarikaankur 210x32x2.0 72104 vasak			
Kontrollis				Tähis: KR320			
			Leht: 1 Lehti: 1	Muudat. -XX		Tootekaart	

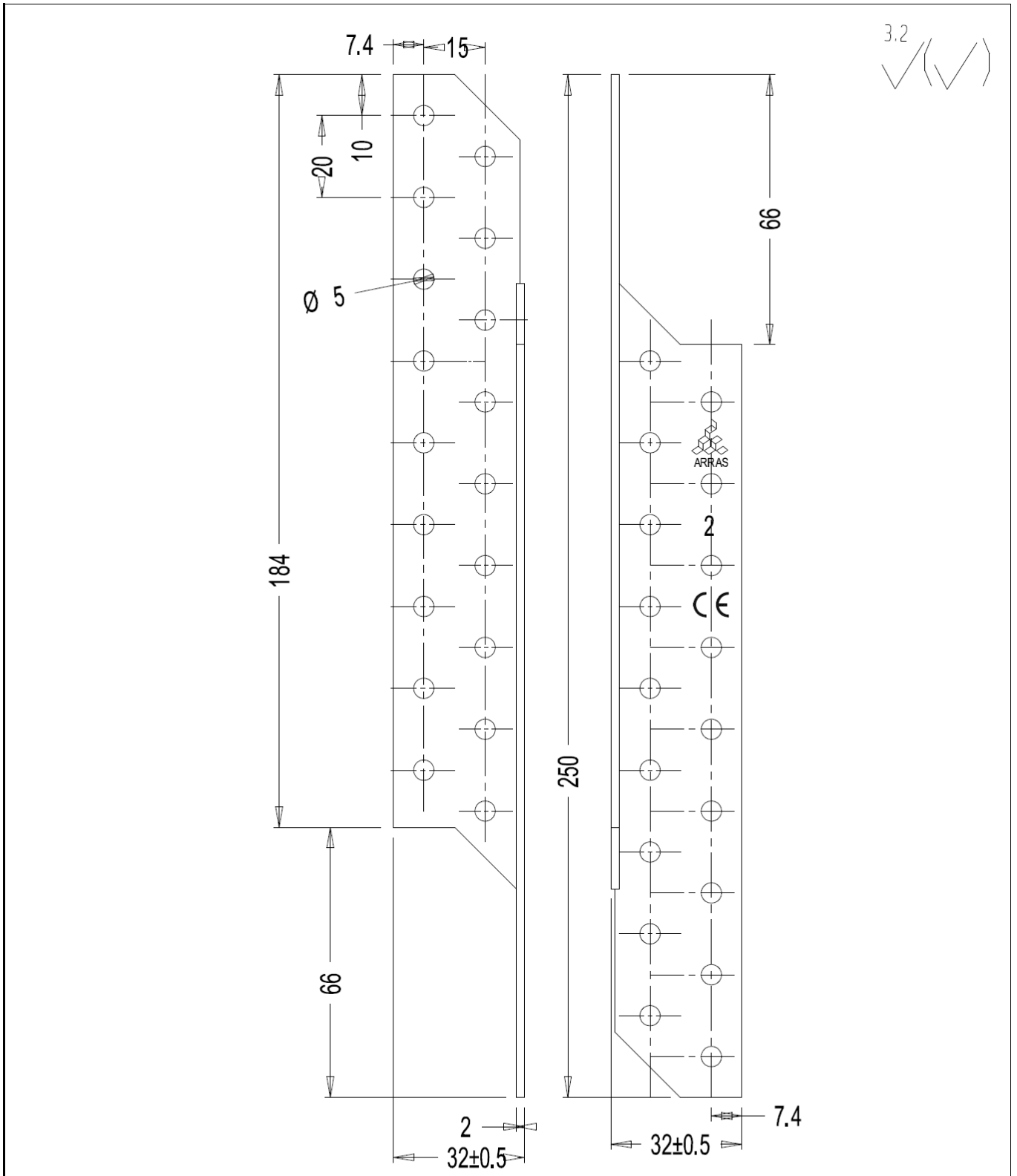

Materjal: HDG DX51D Z275 MAC				Arv: X tk.	Mass:	Mõõt: M1:1	A4
Konstruktor	R.K.		12,09,16	Ninetus: Sarikaankur 250x32x2.0 72105 parem			
Kontrollis							
			Lehti: 1 Lehti: 1	Tõhis: KR320		Muudot: -XX	Tootekaart

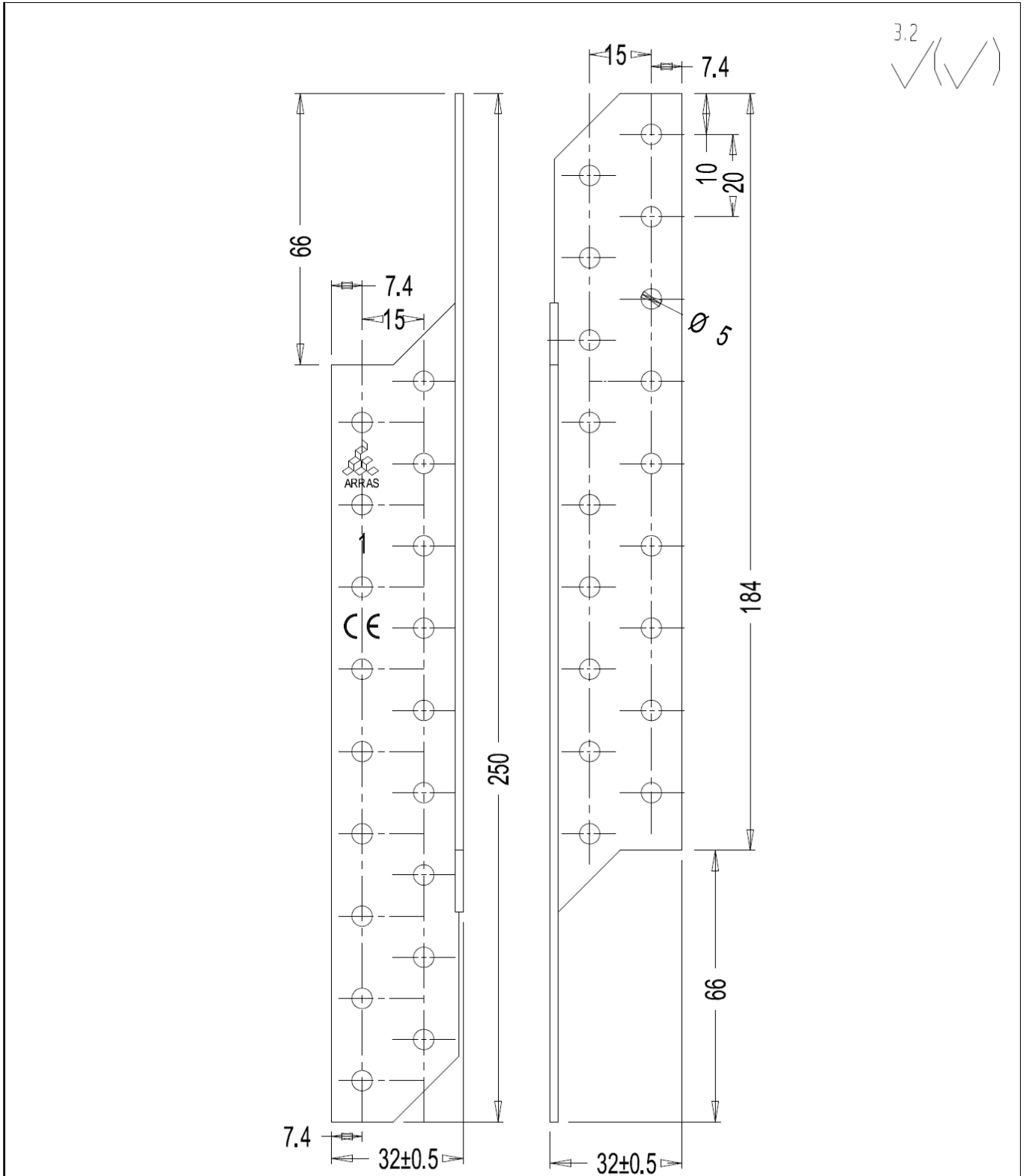

Materiaali: HDG DX51D Z275 MAC.				Arv: X tk.	Määr: _____	Määr: M1:1	A4
Konstruktori	R.K.	12,09,16	Nimetus: Sarikaankur 250x32x2.0 72106 vasak				
Kontrollis			Tähis: KR320				
		Lehti: 1 Lehti: 1	Muudat. -XX		Tootekaart		

ANNEX 1: Product details and definitions

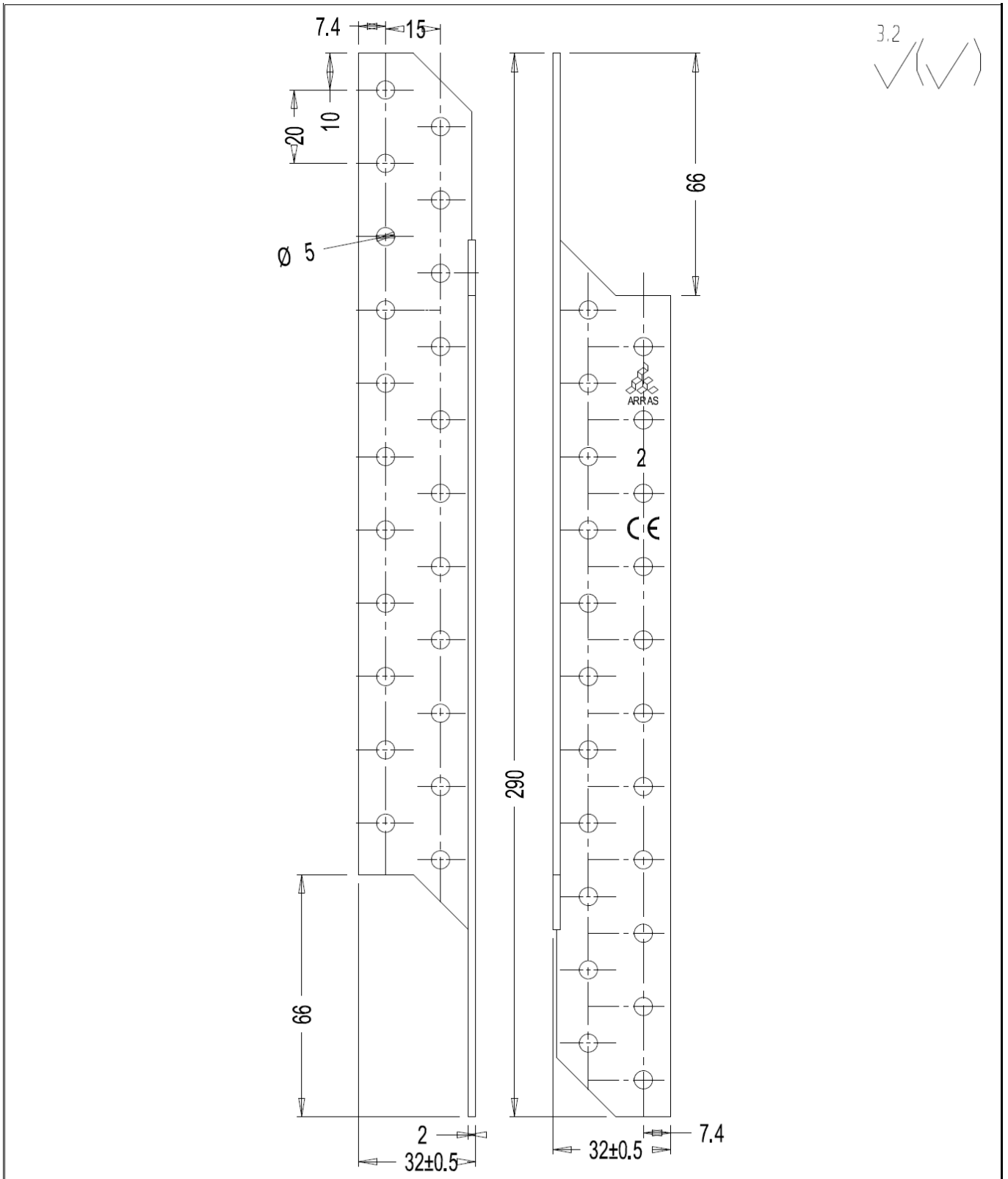

Materjal: HDG DX51D Z275 MAC			Arv: X tk.	Moss:	Mõõt: M1:1	A4
Konstruktor	R.K.	12,09,16	Nimetus: Sarikaankur 290x32x2.0 72107 parem			
Kontrollis						
		Leht: 1 Lehti: 1	Tähis: KR320		Muudat. -XX	Tootekaart

ANNEX 1: Product details and definitions

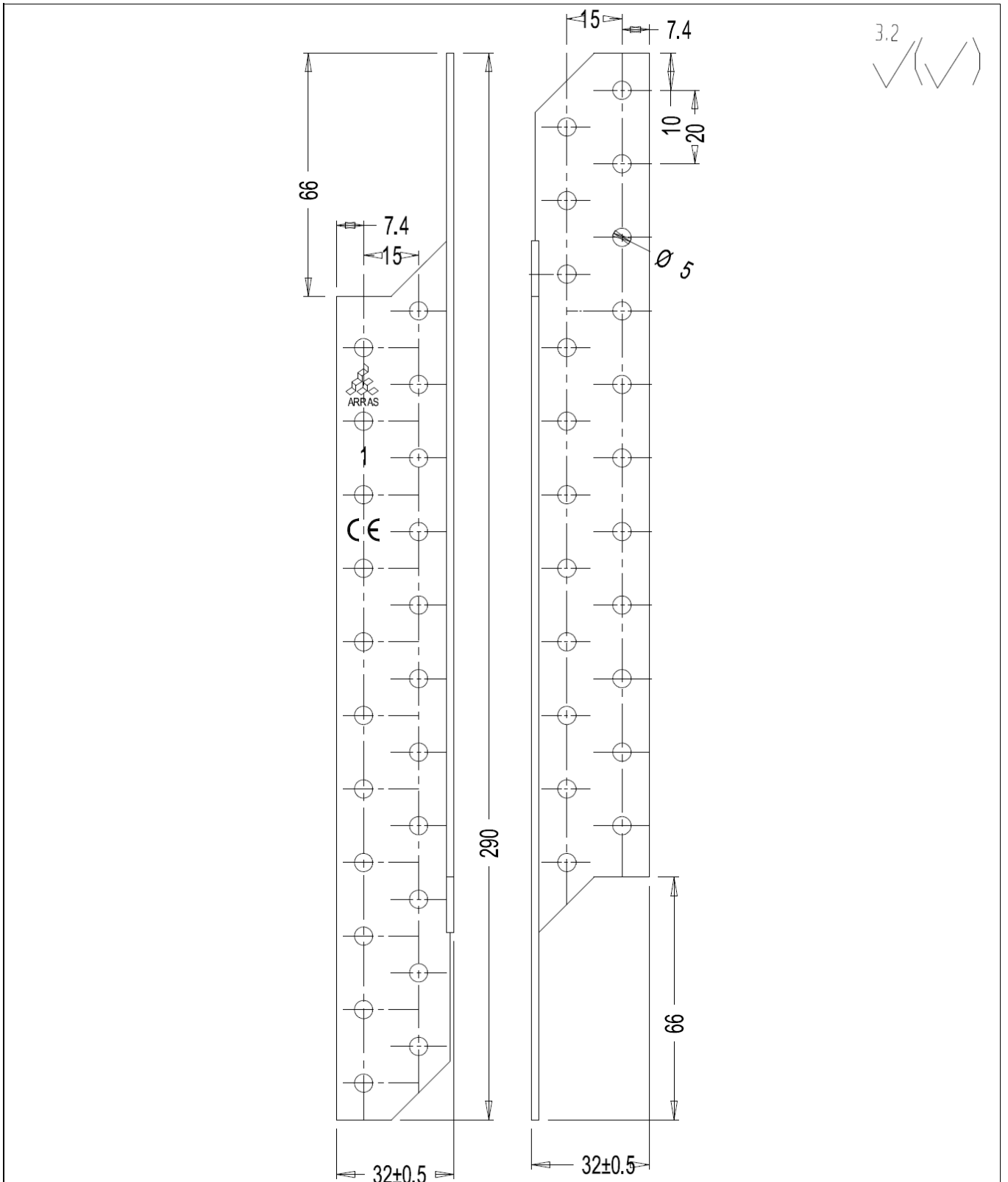

Materjal: HDG DX51D Z275 MAC				Arv: X tk.	Mass:	Mõõt: M1:1	A4
Konstruktor	R.K.	12,09,16	Ninetus Sarikaankur 290x32x2.0 72108 vasak				
Kontrollis							
			Leht: 1	Tähis: KR320		Muudat. -XX	Tootekaart
			Lehti: 1				

ANNEX 1: Product details and definitions

3.2

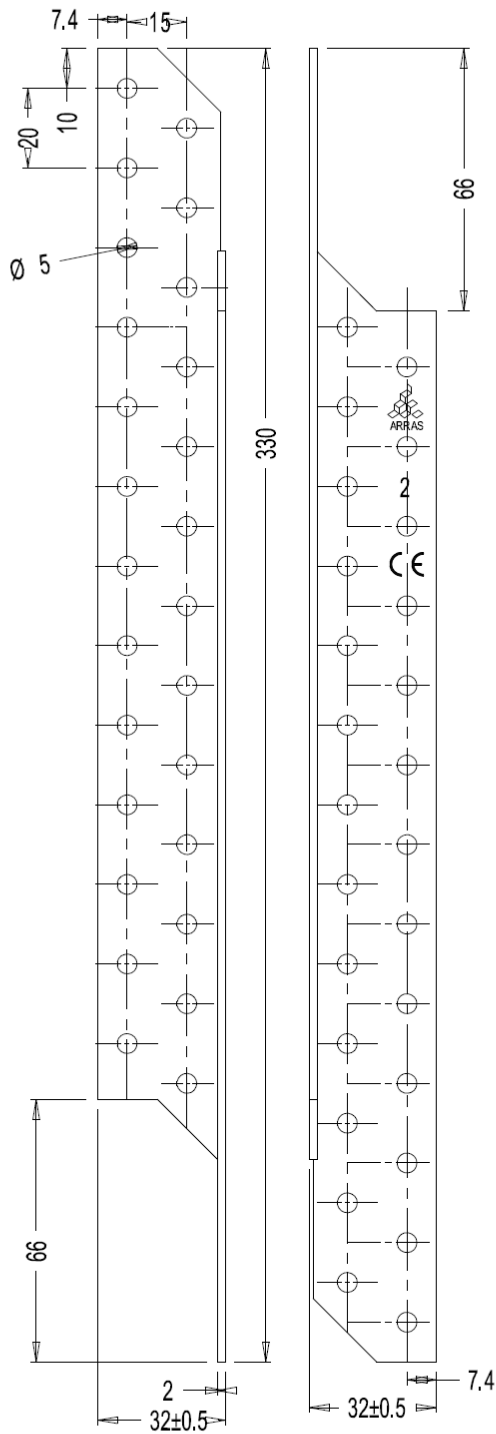

Materjal:		HDG DX51D Z275 MAC.		Arv: X tk.	Mass:	Mõõt: M1:1	A4
Konstruktor	R.K.		12,09,16	Ninetus: Sarikaankur 330x32x2.0 parem 72109			
Kontrollis							
			Lehti: 1	Tähis: KR320	Muudot: -XX	Tootekaart	
			Lehti: 1				

ANNEX 1: Product details and definitions

3.2

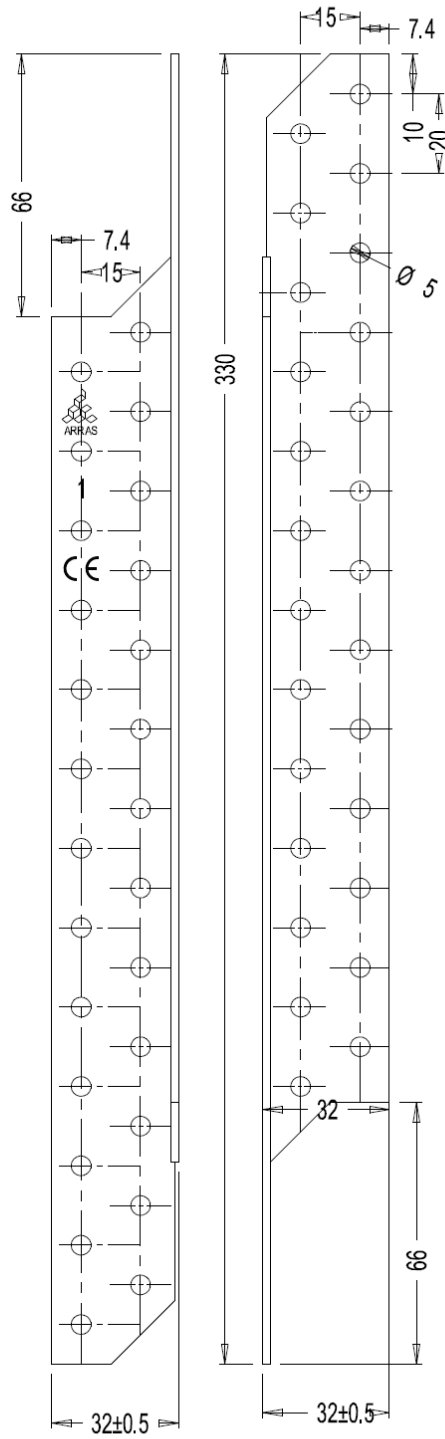

Materjal:		HDG DX51D Z275 MAC.		Arv:	X tk.	Moss:	M6õt: M1:1	A4	
Konstruktor	R.K.		12,09,16	Ninetus:					
Kontrollis				Sarikoankur 330x32x2.0					
				vasak 72110					
				Leht:	1	Tõhis:		Muudot.	Tootekaart
				Lehti:	1				

ANNEX 1: Product details and definitions

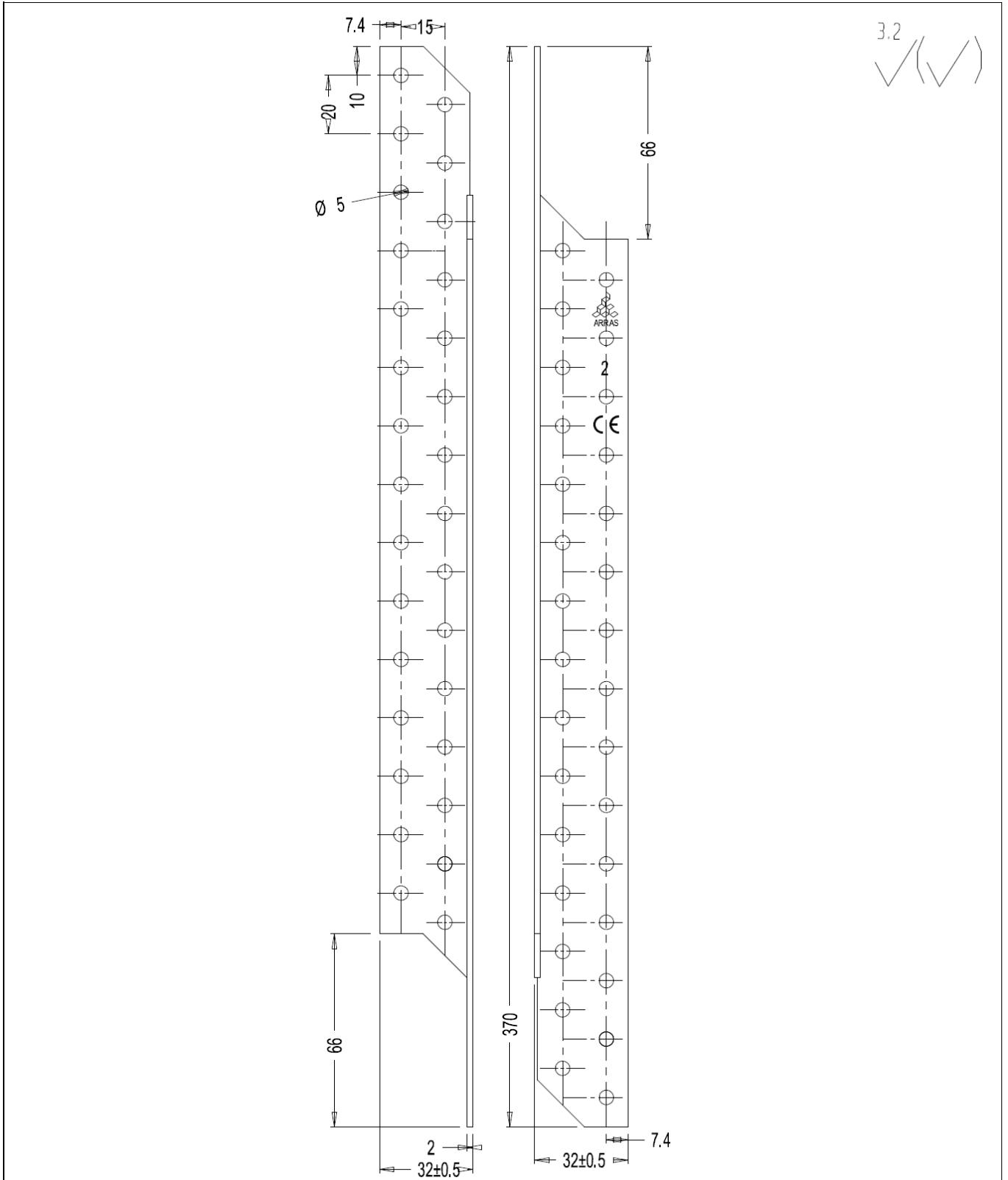

Materjal:		HDG DX51D Z275 MAC.		Arv:	X tk.	Moss:	Mõõt: M1:1	A4
Konstruktor	R.K.		12,09,16	Ninetus: Sarikoankur 370x32x2.0 parem 72111				
Kontrollis				Tähis:		Muudat.	Tootekaart	
			Leht: 1	KR320		-XX		
			Lehti: 1					

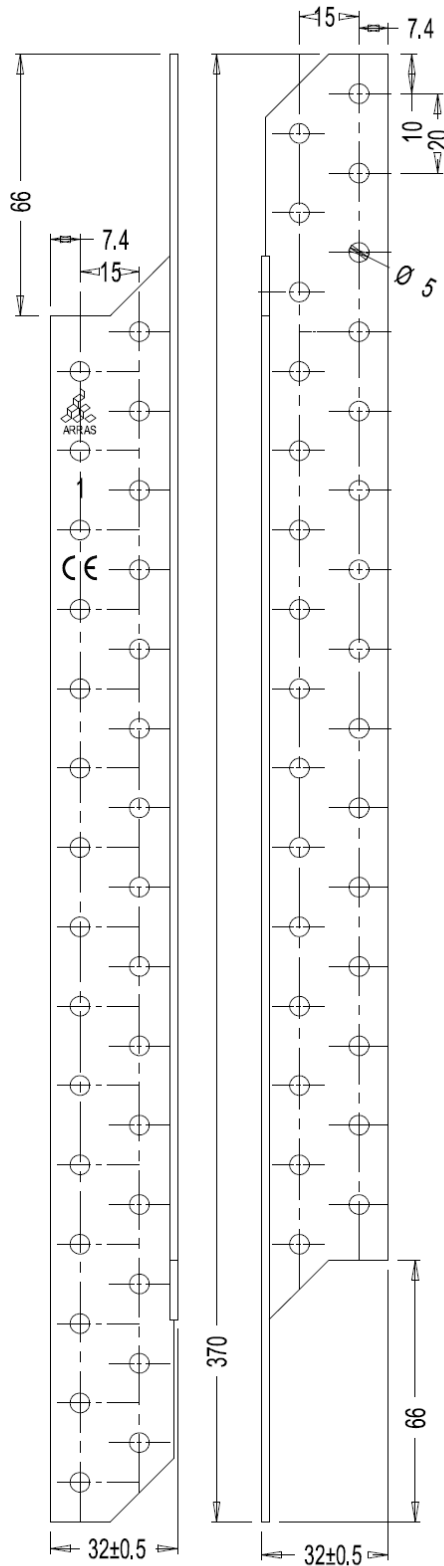

3.2  

Materjal:		HDG DX51D Z275 MAC.		Arv:	X tk.	Mass:	Mõõt:	M1:1	A4
Konstruktor	R.K.		12,09,16	Ninetus:					
Kontrollis				Sarikaankur 370x32x2.0					
				vasak 72112					
				Leht:	1	Tõhis:	KR320		
				Lehti:	1	Muudot.	-XX		
							Tootekoart		

## ANNEX 2. CHARACTERISTIC LOAD-CARRYING CAPACITIES

### Characteristic resistances for EJOT Purlin Anchors - calculation method

#### Lateral load-carrying capacity of fastener

The characteristic load-carrying capacity for nails and screws in EJOT Purlin Anchor connections per fastener should be taken as the minimum value found from the following expressions:

- for a thick fastener  $d \geq 4$  mm:

$$F_{v,Rk} = \min \begin{cases} 0,4f_{h,k}t_1d & \text{(a)} \\ 1,15\sqrt{2M_{y,Rk}f_{h,k}d} + \frac{F_{ax,Rk}}{4} & \text{(b)} \end{cases} \quad (1)$$

- for a thin fastener  $d \leq 2$  mm:

$$F_{v,Rk} = \min \begin{cases} f_{h,k}t_1d & \text{(a)} \\ f_{h,k}t_1d \left[ \sqrt{2 + \frac{4M_{y,Rk}}{f_{h,k}dt_1^2}} - 1 \right] + \frac{F_{ax,Rk}}{4} & \text{(b)} \\ 2,3\sqrt{M_{y,Rk}f_{h,k}d} + \frac{F_{ax,Rk}}{4} & \text{(c)} \end{cases} \quad (2)$$

- for a fastener  $2 \text{ mm} < d < 4 \text{ mm}$ , linear interpolation between equations (1) and (2) is used.

In equations (1) and (2) the penetration length of fastener in timber  $t_1 = L - t$ , when  $L$  is the length of fastener and  $t$  is the thickness of steel plate,  $d$  is the nominal diameter of nail or the effective diameter of screw  $= 1,1\bar{d}$ , when  $\bar{d}$  is the inner diameter of threaded part of screw,  $M_{y,k}$  is the characteristic yield moment of the fastener determined according to standards EN 14952 and EN 409,  $F_{ax,k}$  is the characteristic withdrawal capacity of the fastener with a limitation of term  $F_{ax,k}/4$  at maximum to 1/3 with nails and to 1/2 with screws from the load-carrying capacity  $F_{v,Rk}$  and the characteristic embedding strength

$$f_{h,k} = 0,082\rho_k d^{-0,3} \quad \text{N/mm}^2 \quad (3)$$

where  $\rho_k$  is the characteristic density of timber.

The capacity according to equation (2) may be used for anchor nails of diameter 4,0 mm provided, that it has a cone head with minimum conical part length of 4 mm and the minimum cone diameter of 5,2 mm at the head of nail.

#### Load-carrying capacity of Purlin Anchor connection

The Purlin Anchors are used as a purlin to beam or a purlin to column connection subjected to a tension load  $F_d$  parallel to the length direction of the connector (see Figure A.2.1). The Purlin Anchors are not assumed to have any load-carrying capacity for lateral forces perpendicular to the length direction of the connector. Two same sizes of connectors with the same number of fasteners are always used symmetrically at both sides of the beam for that a pure tension force would act on the plane of the flange of the connector without any eccentricity.

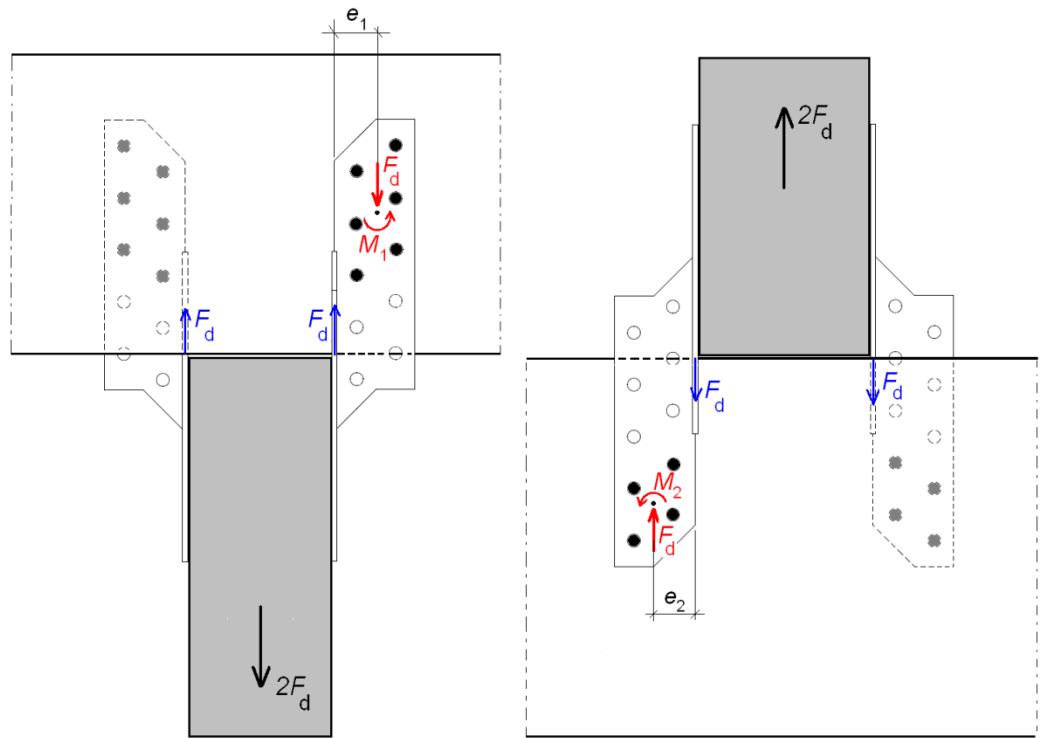

**Figure A.2.1** Use of Purlin Anchors as tension connectors and the forces and moments acting in the Purlin Anchor.

The characteristic load-carrying capacity per purlin anchor should be taken as follows:

- for failure in steel:

$$F_{Rk,S} = 3,66 \text{ kN} \quad (4)$$

- for failure in nailed or screwed timber-to-steel connection:

$$F_{Rk,H} = \min \left\{ \begin{array}{l} \frac{F_{v,Rk,1}}{n_1 + \frac{e_1}{\sum_{i=1}^{n_1} r_{i,1}}} \\ \frac{F_{v,Rk,2}}{n_2 + \frac{e_2}{\sum_{i=1}^{n_2} r_{i,2}}} \end{array} \right. \quad (5)$$

where:

$F_{v,Rk,j}$  is the characteristic lateral load-carrying resistance of the fastener in the timber member of flange  $j = 1$  or 2 calculated according to expressions (1) and (2);

$e_j$  is the eccentricity of the fastener group from the line of bent edge in the flange  $j = 1$  or 2 (see Figure A.2.1);

$r_{i,j}$  is the distance of fastener  $i$  from the centroid of the fastener group in flange  $j$ ;

$n_j$  is the number of fasteners in flange  $j = 1$  or 2.

Values of  $e_j$  and  $\sum r_{i,j}$  for the certain number of fasteners  $n_1$  and  $n_2$  are presented in Table A.2.1, when the fasteners are inserted to the all holes from the ends of the connector (see Figure A.2.1).

**Table A.2.1** Purlin Anchors – article numbers and nominal dimensions. Presented eccentricities  $e_j$  and moments arms  $\Sigma n_j$  are valid for the given number of fasteners  $n_j$ .

Product type name	Art. No.	size (mm)	$e_1$ (mm)	$e_2$ (mm)	$n_1$	$n_2$	$S_{n_1,1}$ (mm)	$S_{n_1,2}$ (mm)
Purlin anchor 170 R	72101 Right	170x32x2,0	16,1	16,1	6	4	103,8	51,6
Purlin anchor 170 L	72102 Left	170x32x2,0	16,1	16,1	6	4	103,8	51,6
Purlin anchor 210 R	72103 Right	210x32x2,0	16,1	16,1	8	6	175,4	103,8
Purlin anchor 210 L	72104 Left	210x32x2,0	16,1	16,1	8	6	175,4	103,8
Purlin anchor 250 R	72105 Right	250x32x2,0	16,1	16,1	10	8	266,6	175,4
Purlin anchor 250 L	72106 Left	250x32x2,0	16,1	16,1	10	8	266,6	175,4
Purlin anchor 290 R	72107 Right	290x32x2,0	16,1	16,1	12	10	377,6	266,6
Purlin anchor 290 L	72108 Left	290x32x2,0	16,1	16,1	12	10	377,6	266,6
Purlin anchor 330 R	72109 Right	330x32x2,0	16,1	16,1	14	12	508,5	377,6
Purlin anchor 330 L	72110 Left	330x32x2,0	16,1	16,1	14	12	508,5	377,6
Purlin anchor 370 R	72111 Right	370x32x2,0	16,1	16,1	16	14	659,2	508,5
Purlin anchor 370 L	72112 Left	370x32x2,0	16,1	16,1	16	14	659,2	508,5

### Design condition

The following design condition shall be satisfied:

$$F_d \leq \min \left\{ \begin{array}{l} k_{\text{mod}} \cdot F_{Rk,H} \\ \gamma_M \\ F_{Rk,S} \\ \gamma_{M0} \end{array} \right. \quad (6)$$

where

- $F_d$  is the design tension force per connector according to Figure A.2.1;
- $k_{\text{mod}}$  is the modification factor according to Eurocode 5 taking into account the effect of the duration of the load and moisture content for the timber member;
- $\gamma_M$  is the partial safety factor for the resistance of connections according to the actual National annex of EN 1995-1-1;
- $F_{Rk,H}$  is the characteristic load-carrying capacity of the connector according to the expression (5);
- $\gamma_{M0}$  is the partial safety factor for the resistance of steel cross-section according to the actual National annex of EN 1993-1-1;
- $F_{Rk,S}$  is the characteristic load-carrying capacity of connector according to the expression (4).

### Structural requirements

The following provisions apply:

- The nailing pattern may be determined by case by case. However, at least two fasteners shall be used in both flanges of the connector.
- All minimum spacings and edge/end distances in accordance with Eurocode 5 shall be complied with.
- The splitting resistance of the timber members shall be verified according to Eurocode 5.
- The cross section of the connected timber members shall have a plane surface without wane against the purling anchor.

- There are no specific requirements relating to preparation of the timber members.
- In service class 2, the nails and screws shall have an electroplated zinc coating according to EN ISO 2081 at least of type and thickness Fe/Zn 12 c, or they shall be hot dip zinc coated according to EN ISO 1461, thickness at least 39 µm.
- The purlin anchors shall not be used without adequate protection for connections where resistance to fire is required.