



European Technical Assessment **ETA 22/0868** of 27/12/2022

I General Part

Technical Assessment Body issuing the ETA	Eurofins Expert Services Oy
Trade name of the construction product	EJOT Angle Brackets
Product family to which the construction product belongs	Three-dimensional nailing plates
Manufacturer	EJOT Baubefestigungen GmbH In der Stockwiese 35 D-57334 Bad Laasphe Germany www.ejot.com
Manufacturing plant	EJOT Plant 52
This European Technical Assessment contains	98 pages including 2 Annexes which form an integral part of this assessment
This European Technical Assessment is issued in accordance with regulation (EU) No 305/2011, on the basis of	EAD 130186-00-0603 for Three-dimensional nailing plates

Translations of this European Technical Assessment in other languages shall fully correspond to the original issued document and should be identified as such.

Communication of this European Technical Assessment, including transmission by electronic means, shall be in full excepted the confidential Annex(es) referred to above. However, partial reproduction may be made, with the written consent of the issuing Technical Assessment Body. Any partial reproduction has to be identified as such.

This European Technical Assessment may be withdrawn by the issuing Technical Assessment Body, pursuant to information by the Commission according to Article 25 Paragraph 3 of Regulation (EU) No 305/2011.

II Specific Part

1 Technical description of the product

The angle brackets covered by this ETA are stated in Tables A2.1 and A2.2 of Annex 2.

EJOT Angle Brackets are one-piece non-welded three-dimensional nailing plates to be used in timber-to-timber or timber-to-concrete connections. The angle brackets are connected to the timber members by anchor nails or screws.

The EJOT Angle Brackets are made from pre-galvanized steel DX51D+Z275 or S250GD+275Z according to EN 10346:2015 or from cold rolled austenitic stainless steel plate of grade 1.4301, 1.4307, 1.4401 or 1.4404 according to the standard EN 10088-2 / EN10088-4 or from grade AISI 304, AISI 304L, AISI 316 or AISI 316L according to the standard ASTM A240/A240M.

In the zinc coated connectors, the yield strength R_{e1} or R_{02} of the steel is at least 250 N/mm², the tensile strength R_m at least 330 N/mm² and elongation at failure A_{80} at least 19 %. Amount of the zinc coating is at least 275 g/m². In stainless steel connectors A4, the yield strength R_{02} of the steel is at least 240 N/mm², the tensile strength R_m at least 530 N/mm² and the elongation at failure A_{80} at least 40 %. In stainless steel connectors A2, the yield strength R_{02} of the steel is at least 220 N/mm², the tensile strength R_m at least 520 N/mm² and the elongation at failure A_{80} at least 45 %.

The product drawings are in Annex 1 and the sizes of EJOT Angle Brackets are listed in tables of Annex 2. The steel material thickness of the zinc coated connectors is $2,00 \pm 0,15$ mm, $2,50 \pm 0,17$ mm or $3,00 \pm 0,20$ mm. The material thickness of stainless steel connectors is $2,00 \pm 0,10$ mm or $2,50 \pm 0,12$ mm. Tolerance for the position of the holes is within $\pm 1,00$ mm.

2 Specification of the intended uses in accordance with the applicable EAD

2.1 Intended uses

Intended use of EJOT Angle Brackets are timber constructions, where both flanges of the bracket are fixed to strength graded timber according to EN 14081-1, glulam according to EN 14080, softwood- or laminated logs, laminated veneer lumber (LVL) according to EN 14374, plywood according to EN 13986, cross laminated timber (CLT) with edge glued lamellas, or corresponding timber material. The characteristic density ρ_k of the timber shall not be greater than 500 kg/m³. This ETA does not cover angle brackets fixed in the end of a timber member or in the edge of a LVL member.

The forces to be transferred by the angle bracket shall act at the centre of the fastener group on the plane defined by flange A. For non-symmetric connections the flange A means the bigger flange. For unclear cases the flange A is presented in figures of Appendix 1. Shear capacity represents the force component that is in effect in direction of a flange surface. Tensile and compression force are the force components that are in effect in direction perpendicular to a flange surface. The obtuse-angled Angle Bracket 135° connectors (angle bracket types 90/40/135° (73104), 90R/135° (73107) and 35/50/135° (73111)) may be loaded only by a shear force parallel to the bent edge of the connector. The long adjustable hole brackets (angle bracket types 35/35/130 (74402) 35/35/130R (74406)) are used typically for fixing non-settling construction members to a log wall and they may be loaded only by tension loads.

EJOT Angle Brackets shall be fixed to timber by anchor nails or anchor screws (see Figure 1) according to EN 14592. The diameter of the anchor nails shall be $d = 4,0$ mm and the profiled length at least 24 mm. The anchor screw shall have a conical head, the diameter of the smooth part of the screw shall

be $d = 4,5 \dots 5,0$ mm and the inner diameter of the threaded part $d_1 \geq 3,0$ mm. The length of the threaded part of the screw shall be at least $6d$.

Connections with EJOT angle brackets shall fulfil the minimum spacing and edge distance requirement specified in EN 1995-1-1. Timber parts shall not be pre-drilled for the nails or screws. Fasteners shall be perpendicular to the grain of the timber.



Figure 1. Fasteners: a) anchor nail and b) anchor screw.

The flange B of the Angle Bracket may be connected also to other applicable rigid material such as concrete or steel (support side material). In this case, the angle bracket shall be fixed with CE-marked bolts, threaded bars, anchor bolts or concrete screws with diameter 8/10/12 mm through the 9/11/13 mm holes to the rigid material or with concrete screws with diameter of 6 mm through the 7 mm holes. The concrete screws shall have been ETA assessed in accordance with EAD 330232-00-0601 or EAD 330499-01-0601.

For EJOT Angle Brackets made of hot-dip zinc coated steel, the intended service classes according to EN 1995-1-1 are classes 1 and 2. Angle Brackets made of stainless steel can also be used in service class 3.

In service class 2, the nails or screws shall have an electroplated zinc coating according to EN ISO 2081 at least of type and thickness Fe/Zn 12c, or they shall be hot dip zinc coated according to EN ISO 1461, thickness at least 39 μm . In service class 3, the nails or screws shall be made of stainless steel.

2.2 Working life

The provisions made in this European Technical Assessment are based on an assumed intended working life of the angle brackets of 50 years.¹

2.3 Identification

EJOT Angle Brackets are identified by product labels that are marked with "EJOT" logo.

¹ This means that it is expected that when this working life has elapsed, the real working life may be, in normal use conditions, considerably longer without major degradation affecting the essential requirements of the works. The indications given as to the working life of a product cannot be interpreted as a guarantee given by the producer or the assessment body. They should only be regarded as a means for the specifiers to choose the appropriate criteria for products in relation to the expected, economically reasonable working life of the works.

3 Performance of the product and references to the methods used for its assessment

Table 1. Basic requirements for construction works and essential characteristics

Basic requirement and essential characteristics	Performance
BWR 1. Mechanical resistance and stability	
Joint strength	Clause 3.1
Joint stiffness	No performance assessed
Joint ductility	No performance assessed
Resistance to seismic actions	No performance assessed
Resistance to corrosion and deterioration	Clause 3.1
BWR 2. Safety in case of fire	
Reaction to fire	Clause 3.2
Resistance to fire	No performance assessed

3.1 Mechanical resistance and stability, BWR 1

3.1.1 Joint strength

Characteristic resistance values of EJOT Angle Brackets are given in Annex 2.

3.1.2 Resistance to corrosion and deterioration

EJOT Angle Brackets have been assessed as having satisfactory durability and serviceability when used in timber structures when the timber species (including timbers preserved with organic solvent, boron diffusion and related preservatives) described in Eurocode 5 (EN 1995-1-1: 2004) are used and the structures are subject to the dry, internal conditions defined by service classes 1 and 2. Angle Brackets manufactured from stainless steel can also be used in service class 3 provided that also the nails and screws used together with them are made of stainless steel.

3.2 Safety in case of fire, BWR 2

3.2.1 Reaction to fire

EJOT Angle Brackets are made of materials classified to have reaction to fire class A1 according to EN 13501-1.

4 Assessment and verification of constancy of performance (hereinafter AVCP) system applied, with reference to its legal base

According to the Decision 97/638/EC of the European Commission², the system of assessment and verification of constancy of performance (see Annex V to the regulation (EU) No 305/2011) is System 2+.

5 Technical details necessary for the implementation of the AVCP system, as provided for in the applicable EAD.

Technical details necessary for the implementation of the AVCP system are laid down in the control plan deposited at Eurofins Expert Services Oy prior to CE marking.

Issued in Espoo on December 27, 2022³
by Eurofins Expert Services Oy

Katja Vahtikari
Manager, Construction Certification

Saija Korpijaakko
Expert, Construction Certification

² Official Journal of the European Communities L 268 of 1/10/1997

³ This ETA is a reproduction of ETA 20/0273 issued 19/08/2022.

3.2

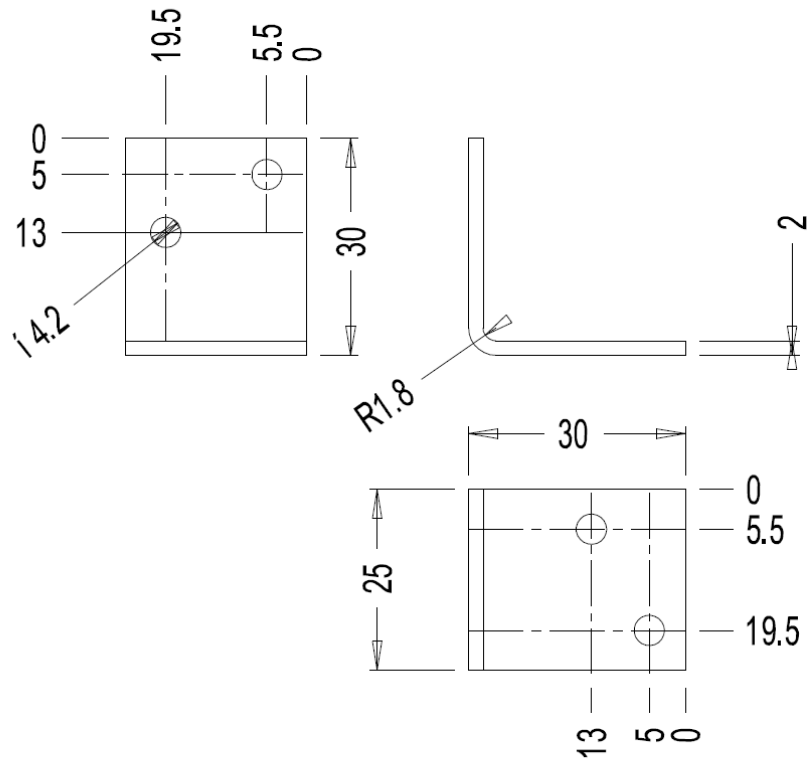
Materjal: HDG DX51D Z275 MAC				Arv: 1 tk,	Moss:	Mõõt: M1:1	A4
Konstruktor	R.K.		10.06.15	Ninetus: Nurgik 30x30x25x2.0 71101			
Kontrollis				Tähis:		Muudot.	Tootekaart
			Leht: 1 Lehti: 1			-XX	

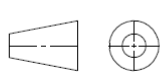
3.2

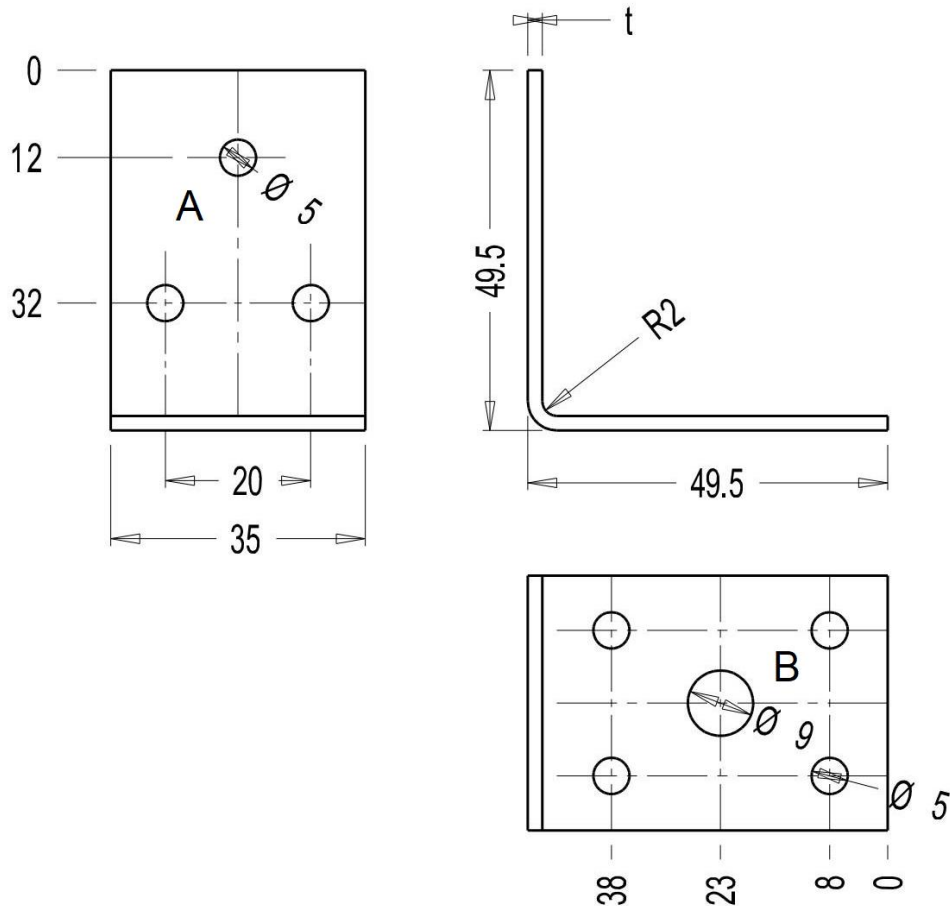

t 2,0 71102

Lubatud toote nimimõõtude tolerantsid:

Haarade pikkused	± 2 mm
Toote samm	± 1 mm
Laius	± 1 mm
Paksus	
2,0 mm	$\pm 0,15$ mm
2,5 mm	$\pm 0,17$ mm
3,0 mm	$\pm 0,20$ mm

Materjal: HDG DX 510 Z275 MAC			Arv: X tk.	Moss:	Mõõt: M1:1	A4
Konstruktor	R.K.	8.05.11	Ninetus: Nurgik 50x50x35 71102			
Kontrollis						
		Leht: 1	Tõhis: KR 184		Muudot. -XX	Tootekoart
		Lehti: 1				

3.2

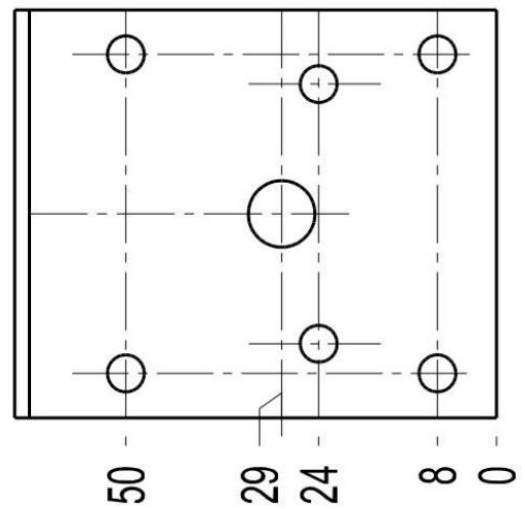
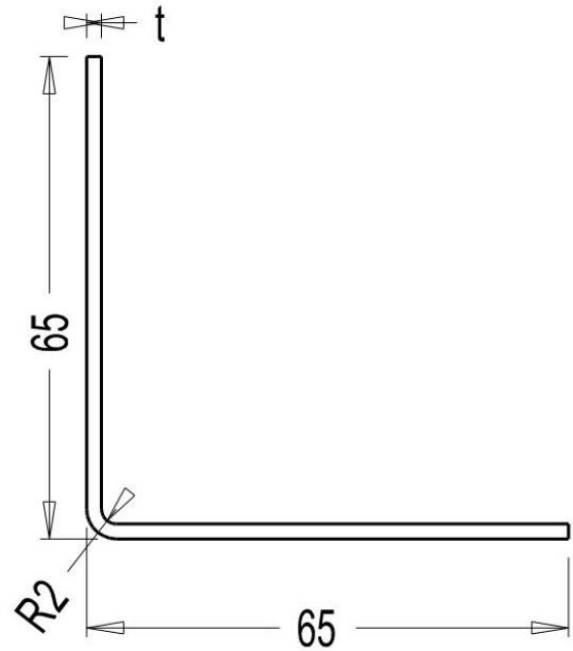
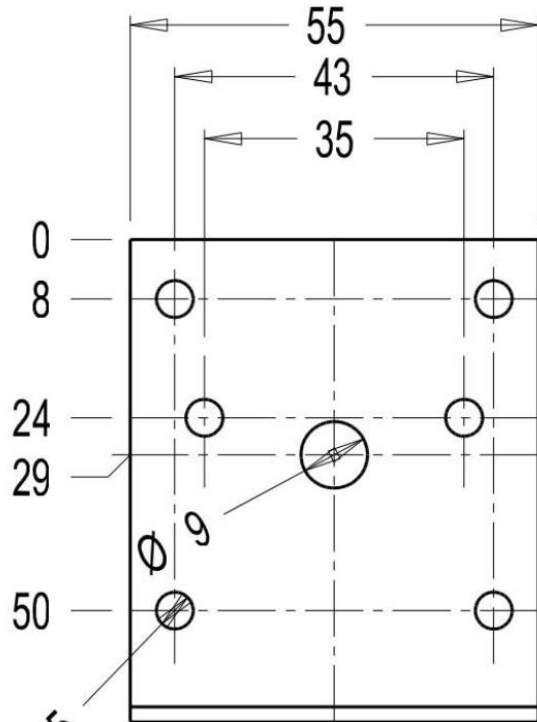

Lubatud toote nimimõõtude tolerantsid:

Haarade pikkused ± 2 mm

Toote samm ± 1 mm

Laius ± 1 mm

Paksus

2,0 mm $\pm 0,15$ mm

2,5 mm $\pm 0,17$ mm

3,0 mm $\pm 0,20$ mm

t 2.0 71103

Materjal: HDG DX51D Z275 MAC				Arv: 1 tk.	Moss:	Mõõt: M1:1	A4
Konstruktor	R.K.		14.05.09	Ninetus: Nurgik 65x65x55 71103			
Kontrollis							
			Leht: 1	Tahis: KR 212	Muudat. -XX	Tootekaart	
			Lehti: 1				

3.2

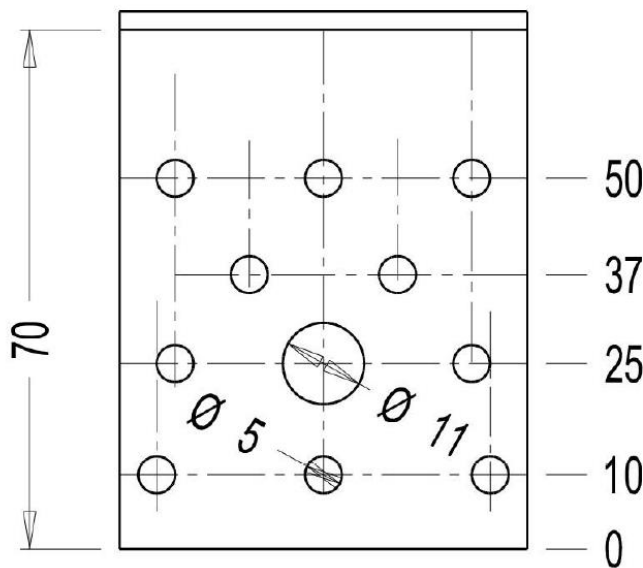
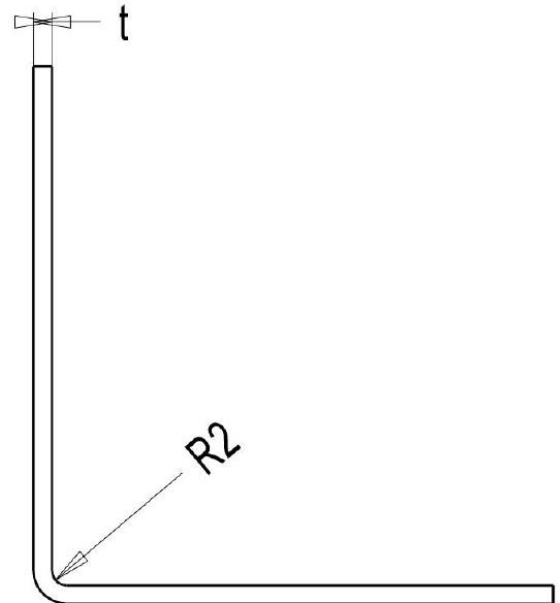
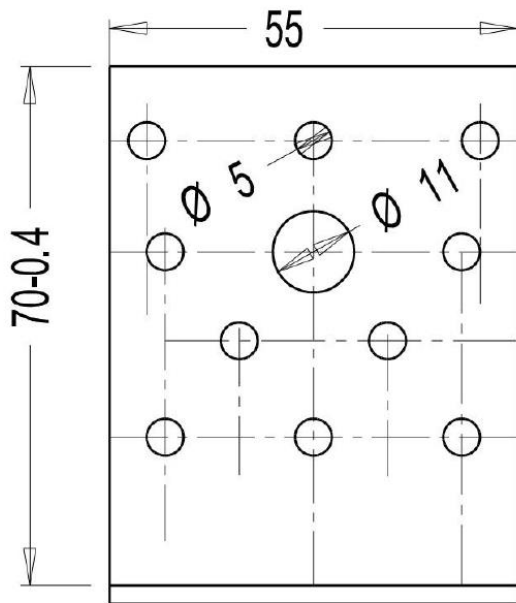

Lubatud toote nimimõõtude tolerantsid:

Haarade pikkused '+/-2 mm

Toote samm '+/-1 mm

Laius '+/-1 mm

Paksus

2,0 mm '+/- 0,15 mm

2,5 mm '+/- 0,17 mm

3,0 mm '+/- 0,20mm

t 2,0 71104

Materjal: HDG DX 510 Z275 MAC				Arv: X tk.	Mass:	Mõõt: M1:1	A4
Konstruktor	R.K.		28.08.10	Ninetus: Nurgik 70x70x55 71104			
Kontrollis							
			Leht: 1 Lehti: 1	Tähis: KR 188	Muudat. -XX	Tootekaart	

3.2

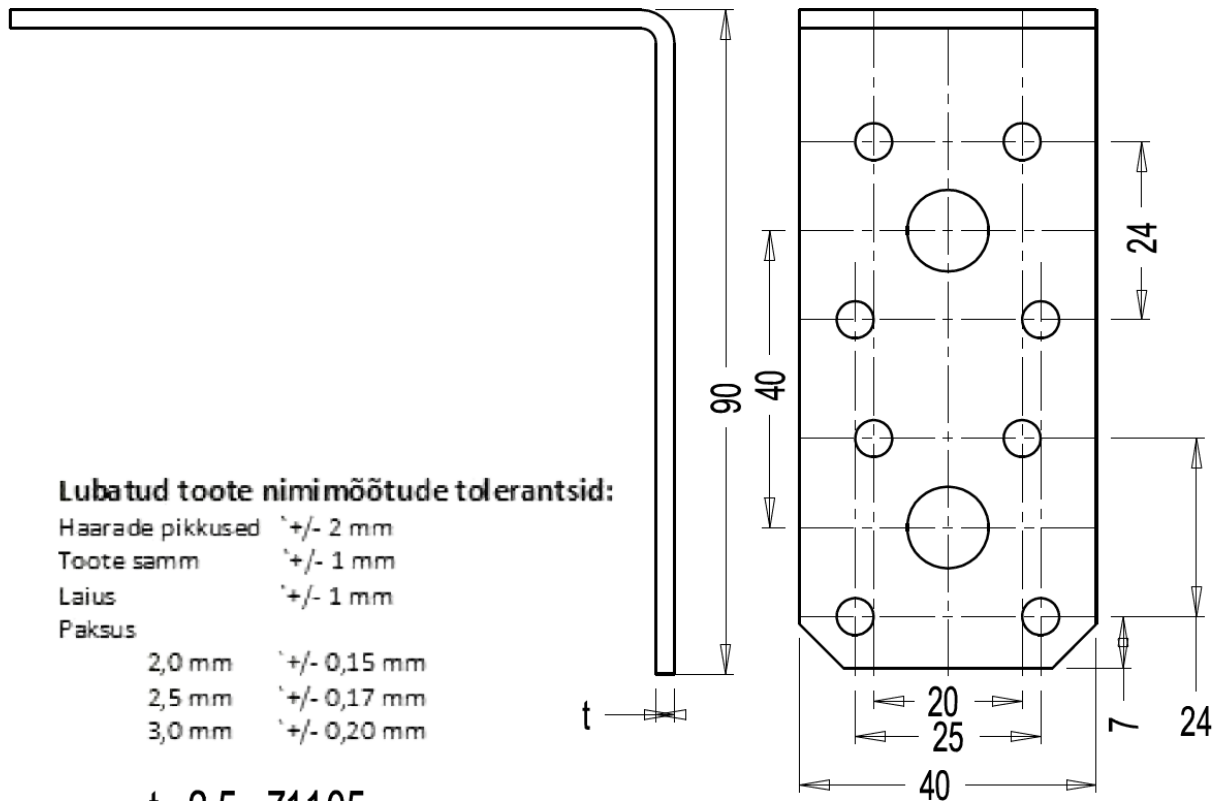
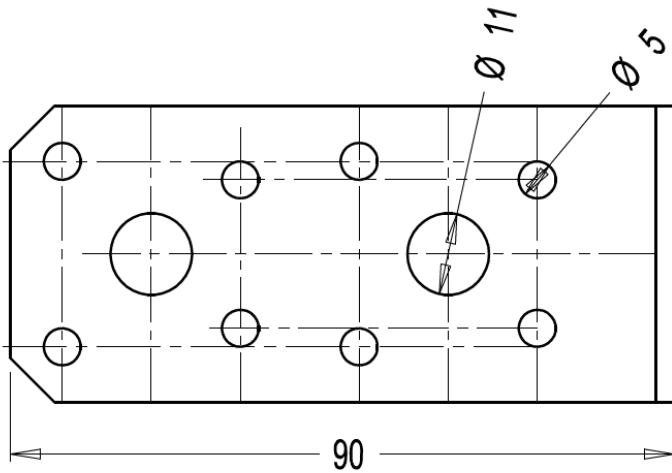

Lubatud toote nimimõõtude tolerantsid:

Haarade pikkused	± 2 mm
Toote samm	± 1 mm
Laius	± 1 mm
Paksus	
2,0 mm	$\pm 0,15$ mm
2,5 mm	$\pm 0,17$ mm
3,0 mm	$\pm 0,20$ mm

t 2.5 71105

Materjal: HDG DX51D Z275 MAC				Arv: 1 tk.	Moss:	Mõõt: M1:1	A4
Konstruktor	R.K.	28.07.10	Ninetus: Nurgik 90x90x40 71105				
Kontrollis							
			Leht: 1	Tõhis: KR198		Muudat. -XX	Tootekoort
			Lehti: 1				

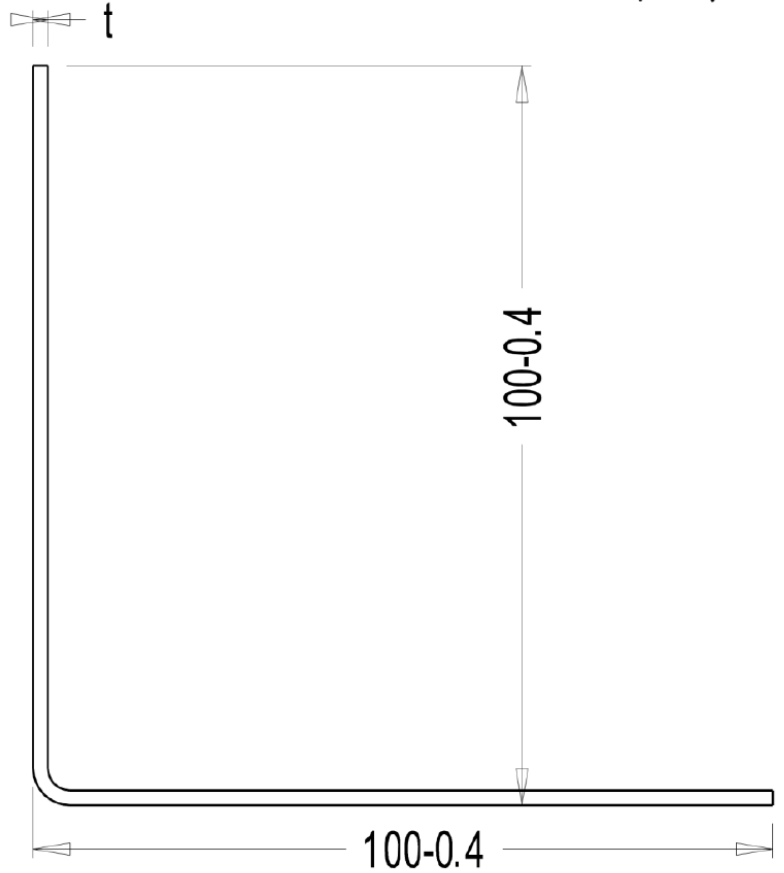
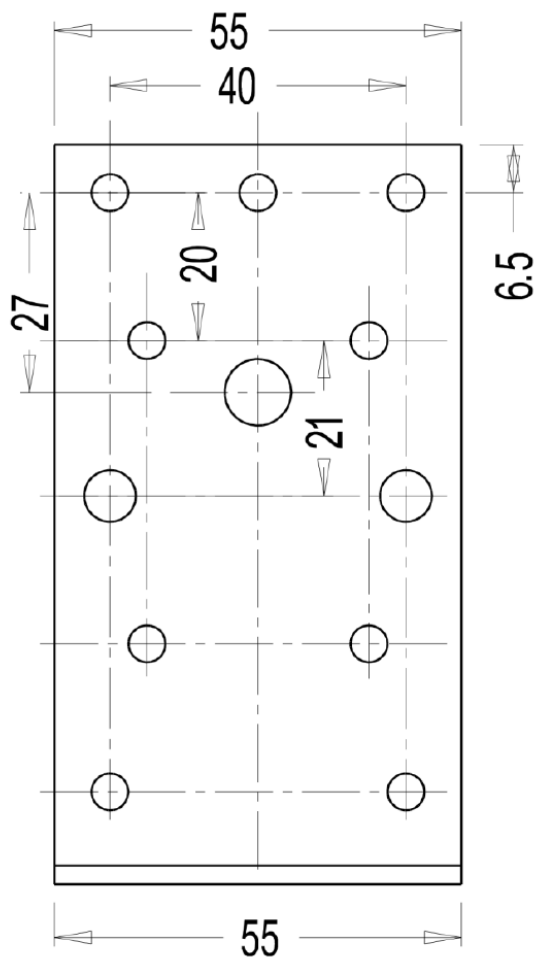

Lubatud toote nimimõõtude tolerantsid:

Haarade pikkused ± 2 mm

Toote samm ± 1 mm

Laius ± 1 mm

Paksus

2,0 mm $\pm 0,15$ mm

2,5 mm $\pm 0,17$ mm

3,0 mm $\pm 0,20$ mm

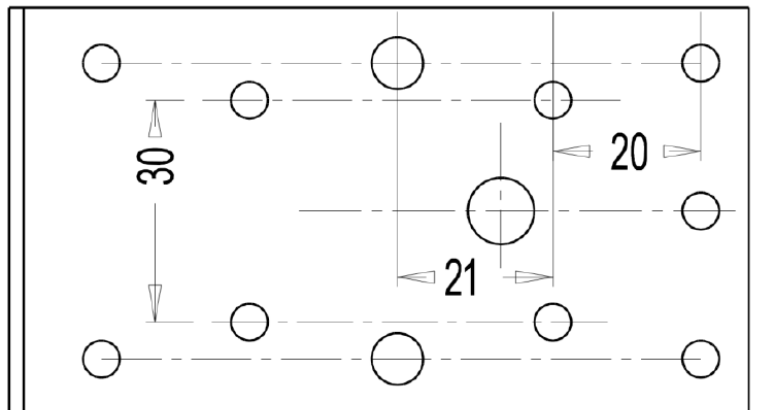

t 2,5 71107

Materjal: HDG DX51D Z275 MAC			Arv: 1 tk.	Mass:	Mõõt: M1:1	A4
Konstruktor	R.K.	15.05.07	Ninetus: Nurgik 100x100x55 71107			
Kontrollis						
		Leht: 1 Lehti: 1	Tähis: KR195	Muudat. -XX	Tootekaart	

3.2

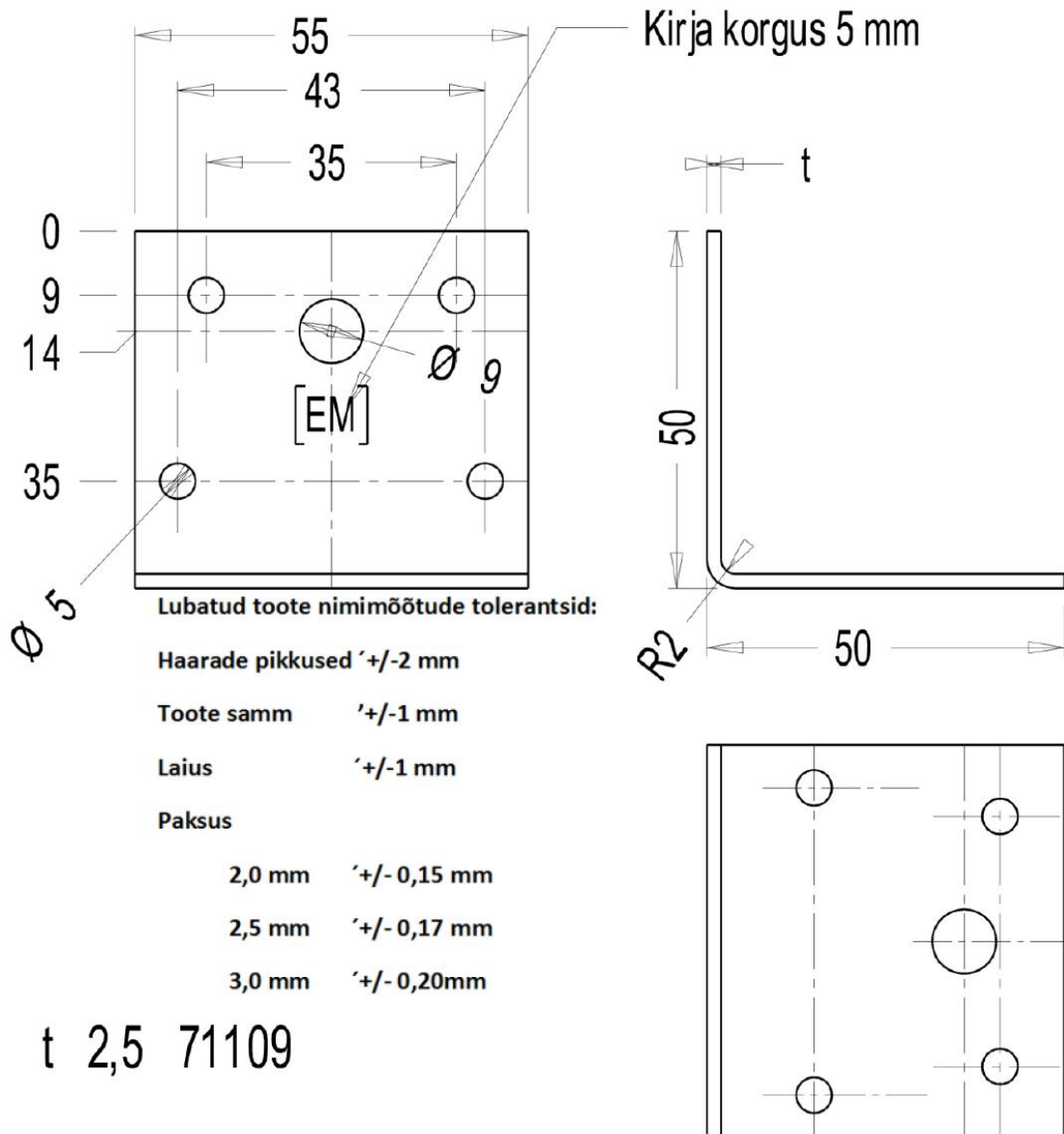
Materjal: HDG DX51D Z275 MAC				Arv: 1 tk.	Mass:	Mõõt: M1:1	A4
Konstruktor	R.K.		14.05.09	Ninetus: Nurgik 50x50x55 71109			
Kontrollis							
			Leht: 1 Lehti: 1	Tähis: KR 212.4	Muudat. -XX	Tootekaart	

3.2

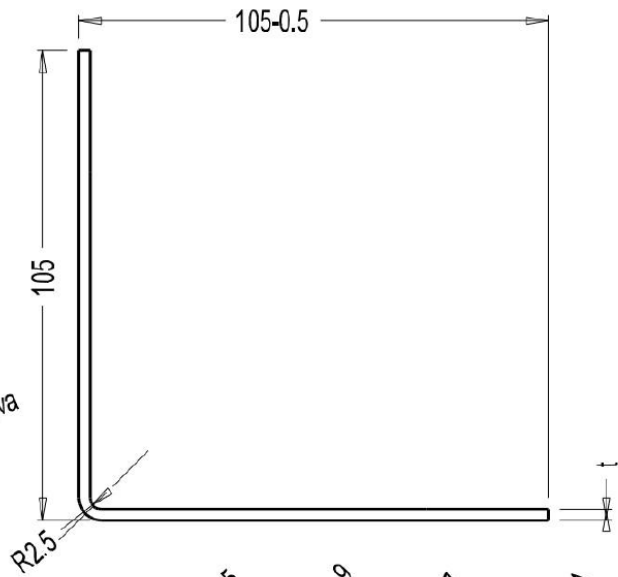
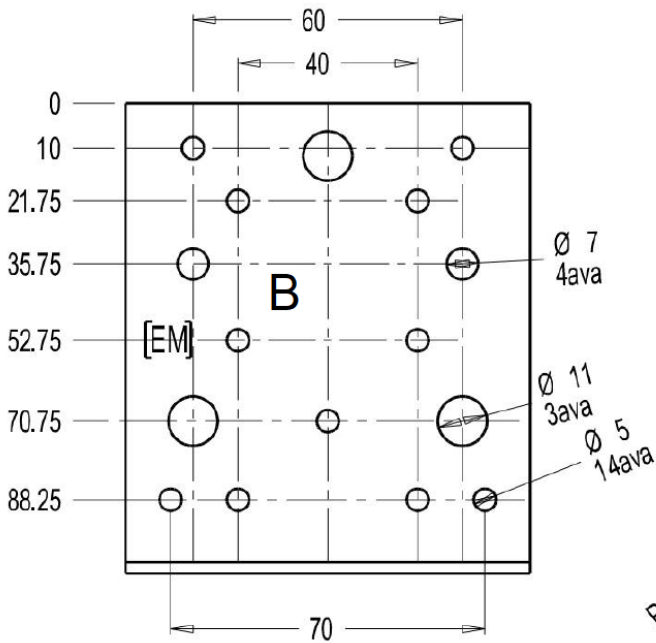

Lubatud toote nimimõõtude tolerantsid:

Haarade pikkused '+/-2 mm

Toote samm '+/-1 mm

Laius '+/-1 mm

Paksus

2,0 mm '+/- 0,15 mm

2,5 mm '+/- 0,17 mm

3,0 mm '+/- 0,20mm

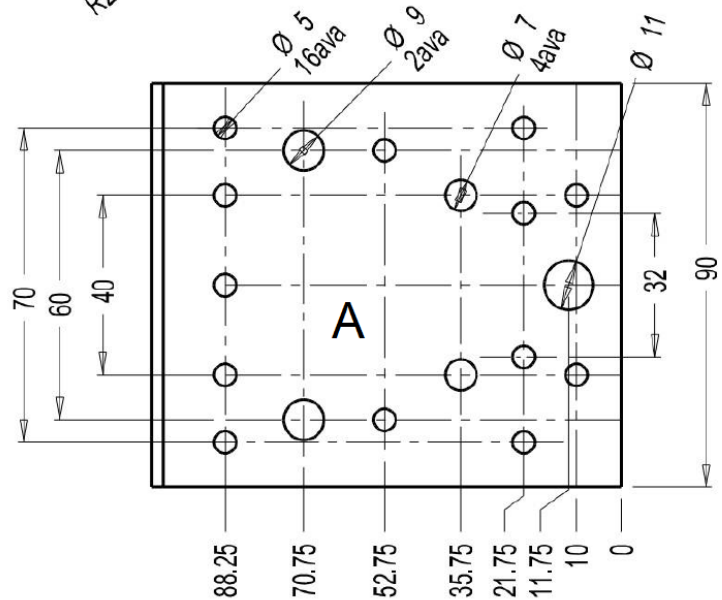

t 2,0 71112

Materjal: HDG DX51D Z275 MAC				Arv: 1 tk.	Mass:	Mõõt: M1:1	A4
Konstruktor	R.K.		30.10.09	Ninetus: Nurgik 105x105x90 71112			
Kontrollis							
			Leht: 1 Lehti: 1	Tähis: KR 217	Muudat. -XX	Tootekoart	

3.2

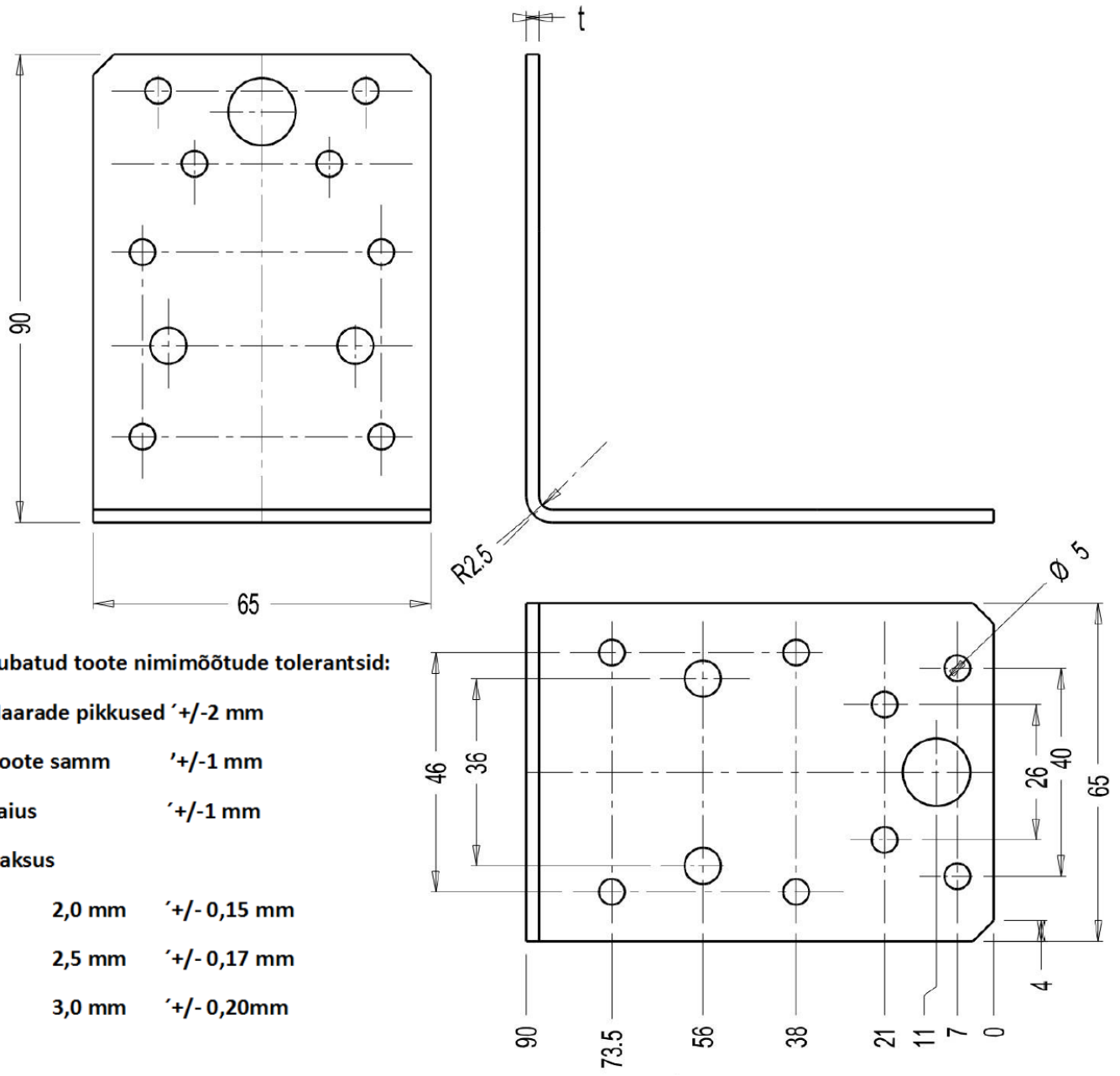
Lubatud toote nimimõõtude tolerantsid:

Haarade pikkused ± 2 mm

Toote samm ± 1 mm

Laius ± 1 mm

Paksus

- 2,0 mm $\pm 0,15$ mm
- 2,5 mm $\pm 0,17$ mm
- 3,0 mm $\pm 0,20$ mm

t 2,0 71115

Materjal: HDG DX 510 Z275 MAC			Arv: X tk.	Mass:	Mõõt: M1:1	A4	
Konstruktor	R.K.	XX.XX.XX	Ninetus: Nurgik 90x90x65 71115				
Kontrollis							
				Leht: 1	Tähis: KR 186	Muudat. -XX	Tootekaart
				Lehti: 1			

3.2

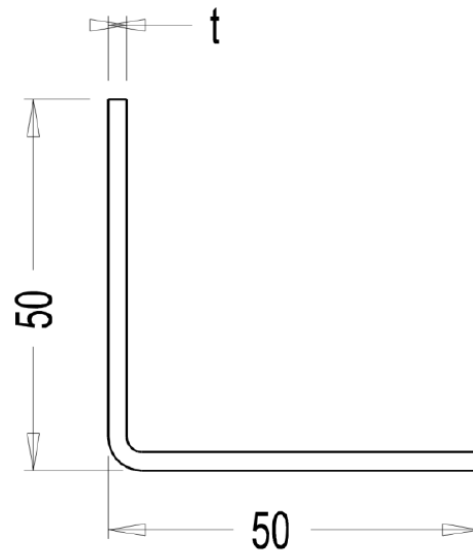
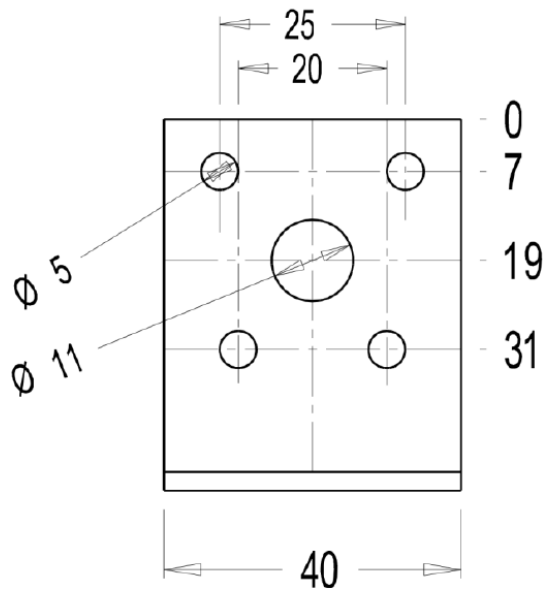

Lubatud toote nimimõõtude tolerantsid:

Haarade pikkused ± 2 mm

Toote samm ± 1 mm

Laius ± 1 mm

Paksus

2,0 mm $\pm 0,15$ mm

2,5 mm $\pm 0,17$ mm

3,0 mm $\pm 0,20$ mm

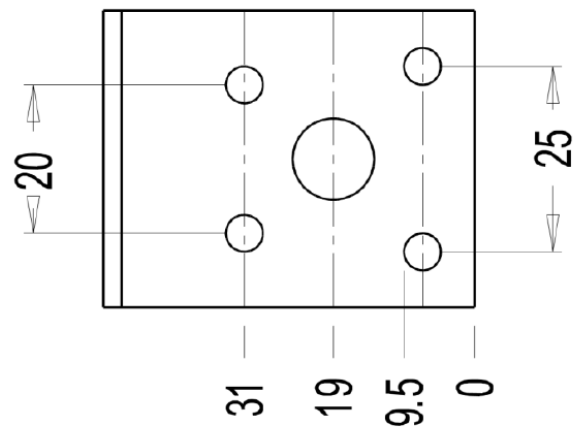

t 2.0 71116

Materjal: HDG DX51D Z275 MAC				Arv: 1 tk.	Mass:	Mõõt: M1:1	A4
Konstruktor	R.K.		6.04.11	Ninetus: Nurgik 50x50x40 71116			
Kontrollis							
			Leht: 1 Lehti: 1	Tähis: KR198	Muudat. -XX	Tootekaart	

3.2

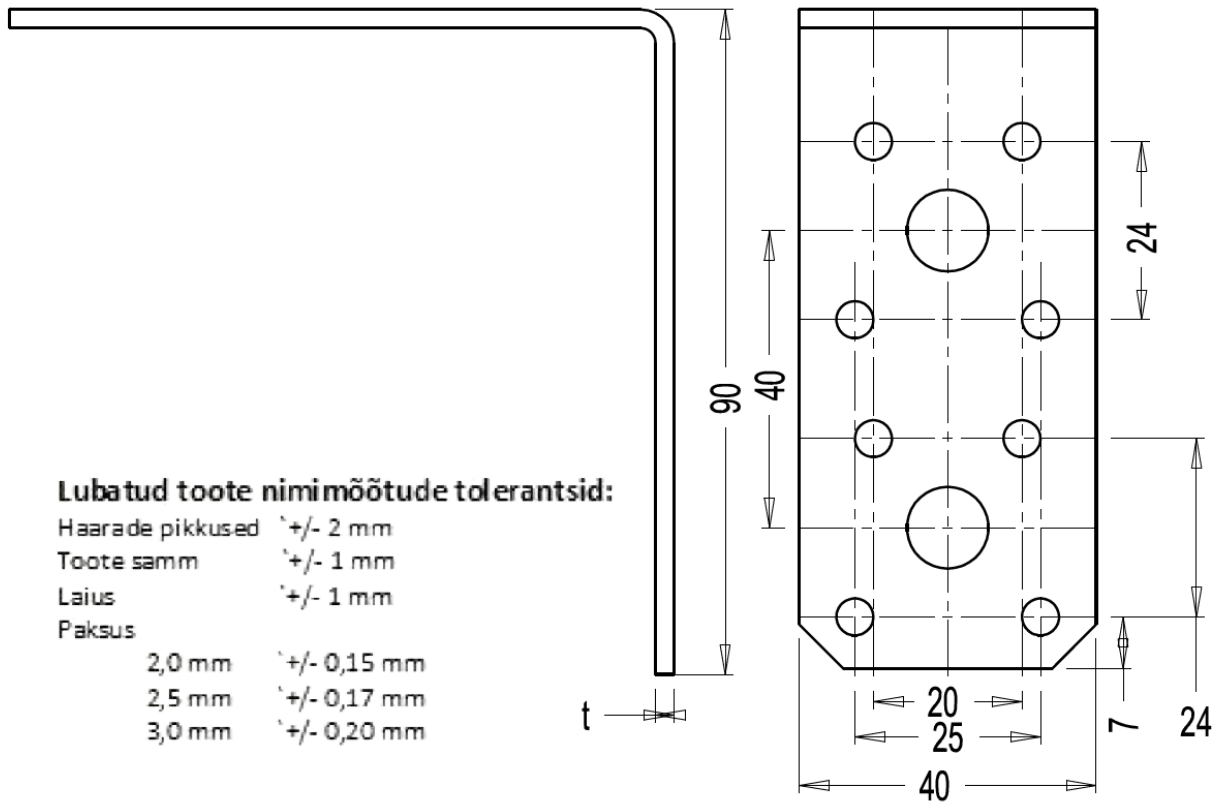
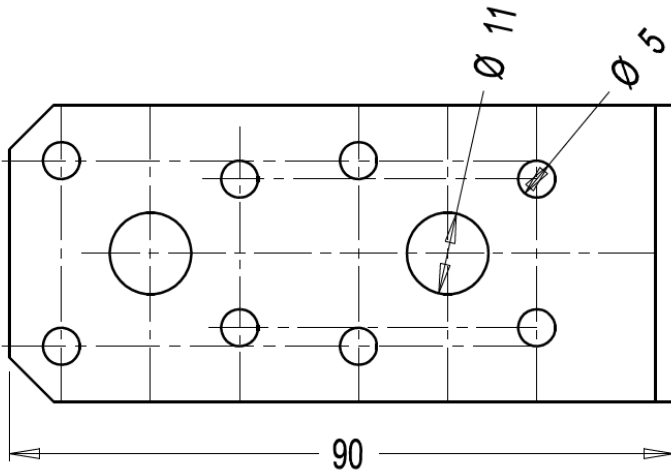

Lubatud toote nimimõõtude tolerantsid:

Haarade pikkused	± 2 mm
Toote samm	± 1 mm
Laius	± 1 mm
Paksus	
2,0 mm	$\pm 0,15$ mm
2,5 mm	$\pm 0,17$ mm
3,0 mm	$\pm 0,20$ mm

t 2.0 71127

Materjal: HDG DX51D Z275 MAC				Arv: 1 tk.	Moss:	Mõõt: M1:1	A4
Konstruktor	R.K.		28.07.10	Ninetus: Nurgik 90x90x40 71127			
Kontrollis							
			Leht: 1 Lehti: 1	Tähis: KR198		Muudat. -XX	Tootekoort

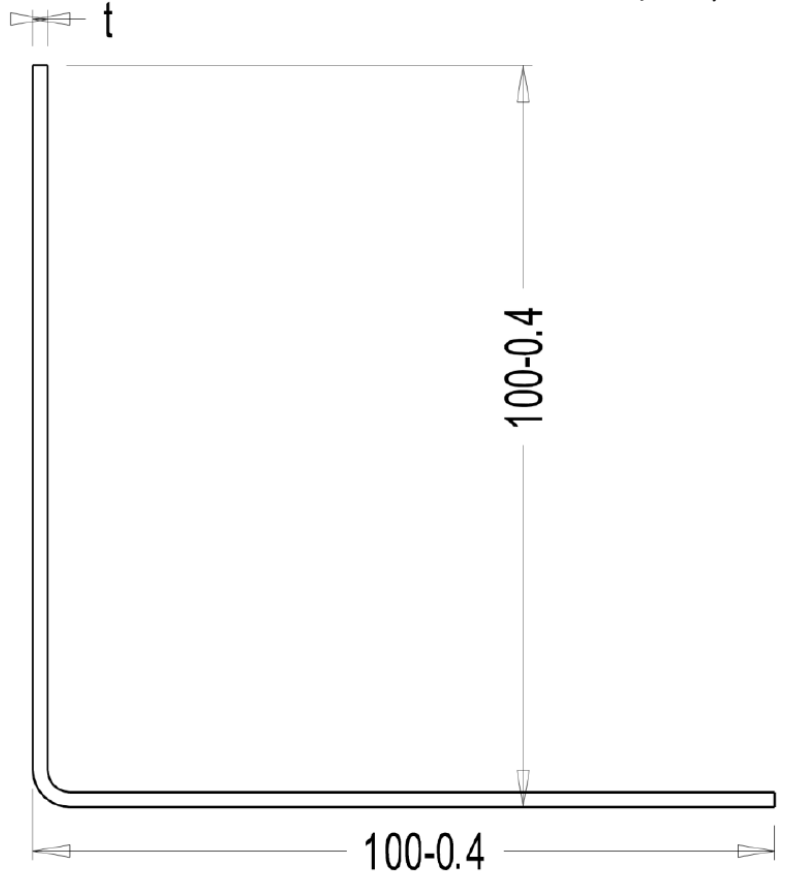
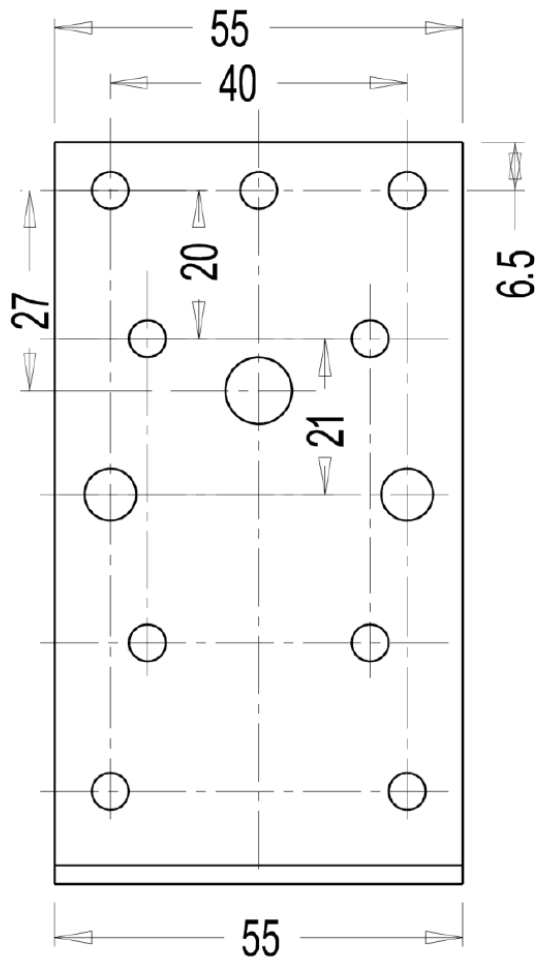

Lubatud toote nimimõõtude tolerantsid:

Haarade pikkused ± 2 mm

Toote samm ± 1 mm

Laius ± 1 mm

Paksus

2,0 mm $\pm 0,15$ mm

2,5 mm $\pm 0,17$ mm

3,0 mm $\pm 0,20$ mm

t 2,0 71131

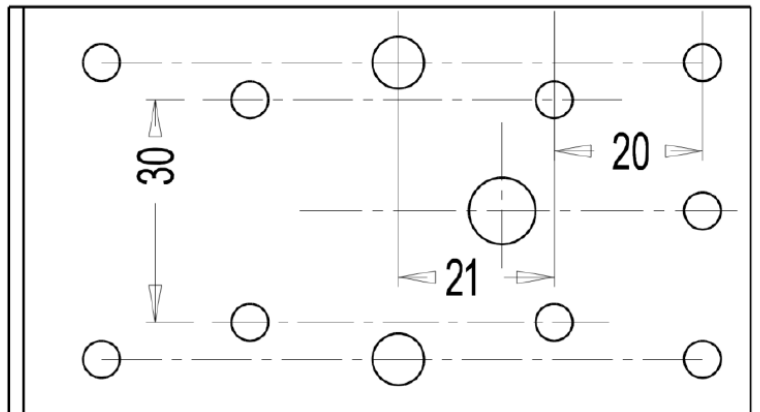

Materjal: HDG DX51D Z275 MAC				Arv: 1 tk.	Mass:	Mõõt: M1:1	A4
Konstruktor	R.K.	15.05.07	Ninetus: Nurgik 100x100x55 71131				
Kontrollis							
			Leht: 1	Tähis: KR195	Muudat. -XX	Tootekaart	
			Lehti: 1				

3.2

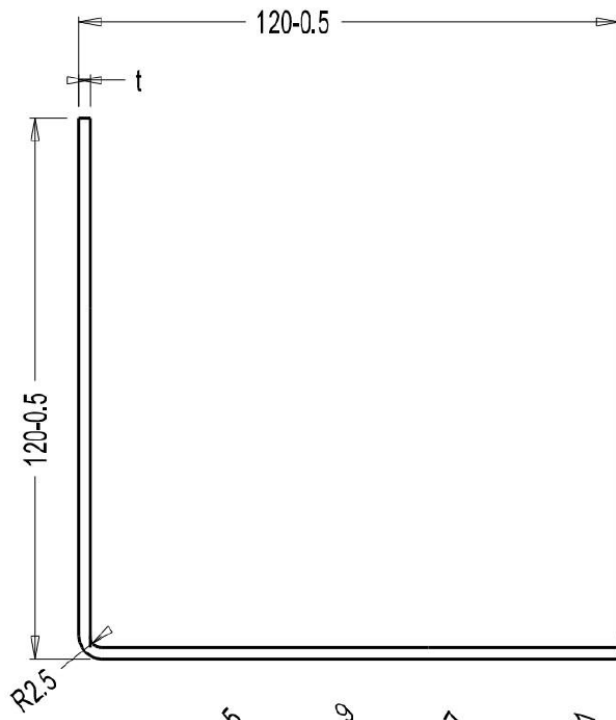
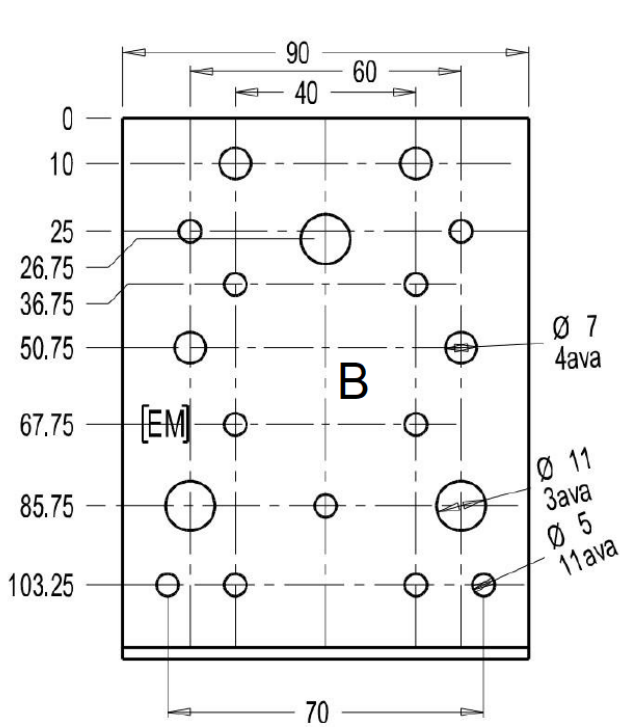

Lubatud toote nimimõõtude tolerantsid:

Haarade pikkused ± 2 mm

Toote samm ± 1 mm

Laius ± 1 mm

Paksus

2,0 mm $\pm 0,15$ mm

2,5 mm $\pm 0,17$ mm

3,0 mm $\pm 0,20$ mm

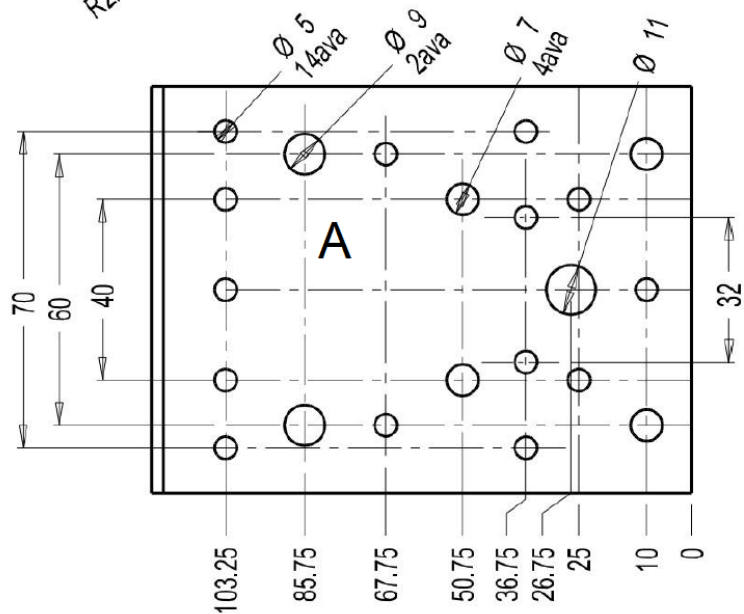

t 2.5 71132

Materjal: HDG DX51D Z275 MAC			Arv: 1 tk.	Mass:	Mõõt: M1:1	A4
Konstruktor	R.K.	30.10.09	Ninetus: Nurgik 120x120x90 71132			
Kontrollis						
			Leht: 1	Tähis: KR 217	Muudat.: -XX	Tootekaart
			Lehti: 1			

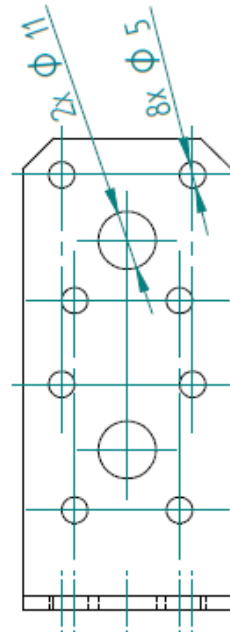
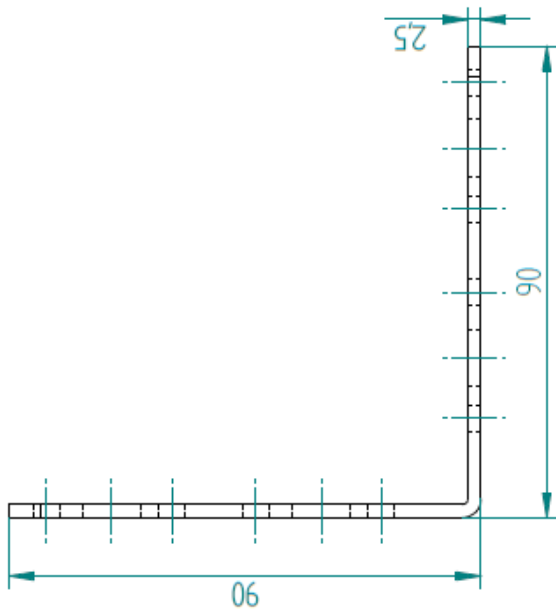
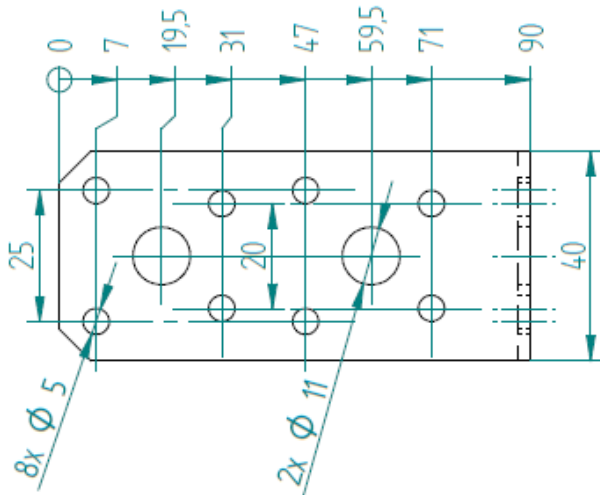
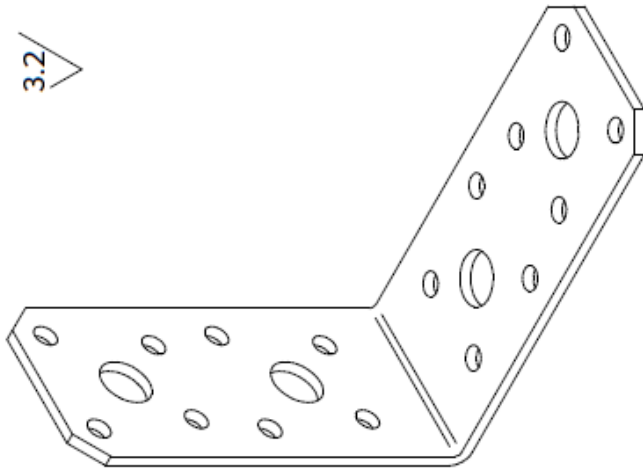

Lubatud toote nimimõõtude tolerantsid:

- Haarade pikkused ± 2 mm
- Toote samm ± 1 mm
- Laius ± 1 mm
- Avad $\pm 0,4$ mm

Materjal:	A2 AISI304	Nimetus:	Nurgik 90x90x40x2,5
Joonestaja:	M.R	ART:	71210
Kontrollis:		Suurus	A4
Kuupäev:	29.03.2021	Starts:	KR-198
		Pinnakate:	A2
		Skaala:	1:1
		Kaal:	0,123 kg

3.2

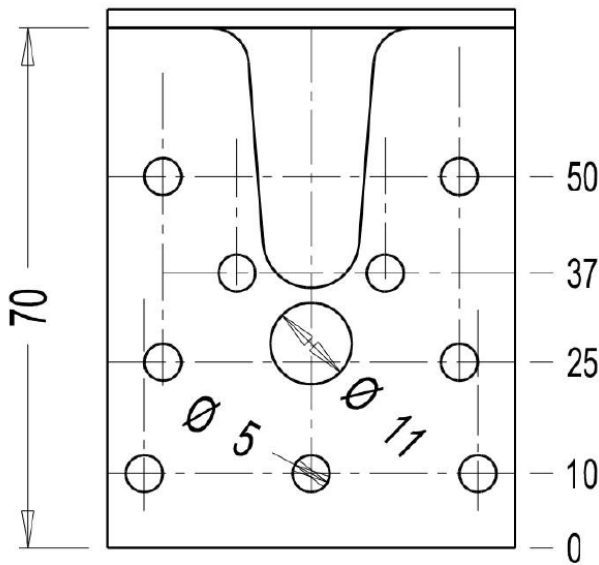
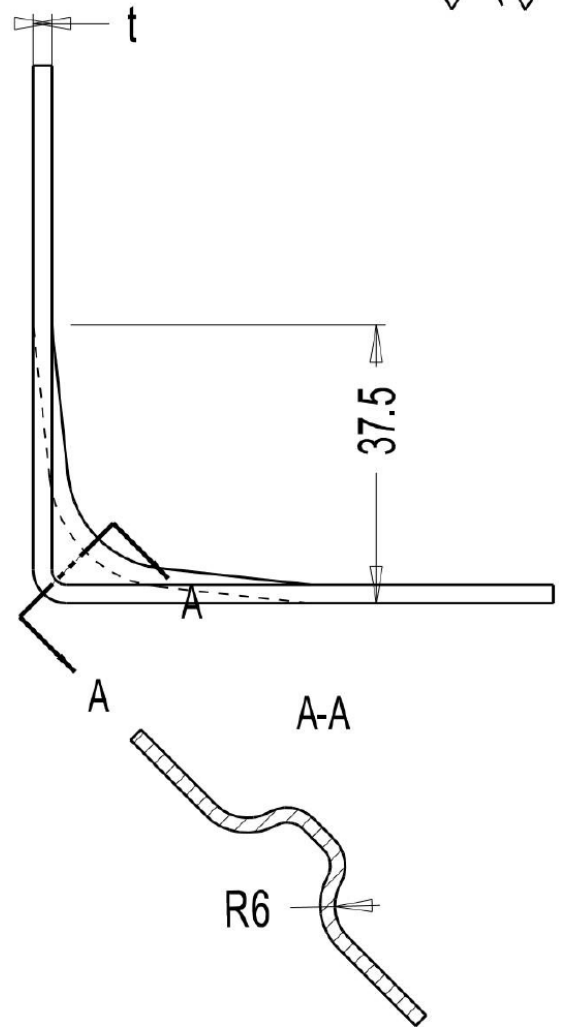
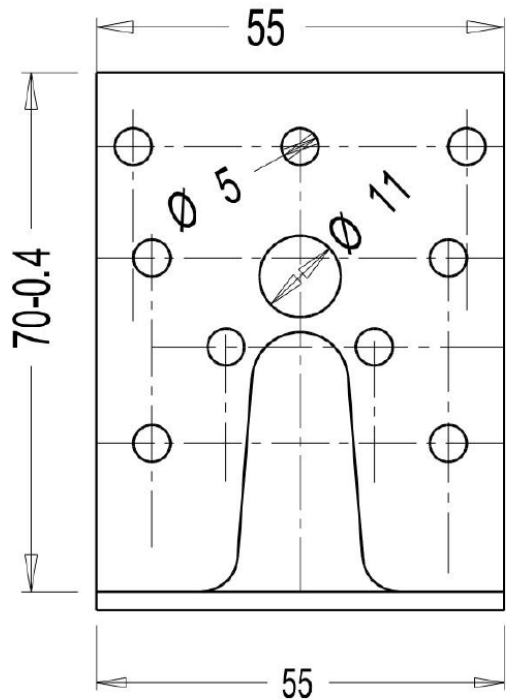

t 2,0 71304

Lubatud toote nimimõõtude tolerantsid:

Haarade pikkused '+/-2 mm

Toote samm '+/-1 mm

Laius '+/-1 mm

Paksus

2,0 mm '+/- 0,15 mm



2,5 mm '+/- 0,17 mm

3,0 mm '+/- 0,20mm

Materjal: HDG DX 510 Z275 MAC				Arv: X tk.	Mass:	Mõõt: M1:1	A4
Konstruktor	R.K.		8.05.11	Ninetus: Nurgik 70x70x55 71304			
Kontrollis							
			Leht: 1 Lehti: 1	Tõhis: KR 188	Muudat. -XX	Tootekaart	

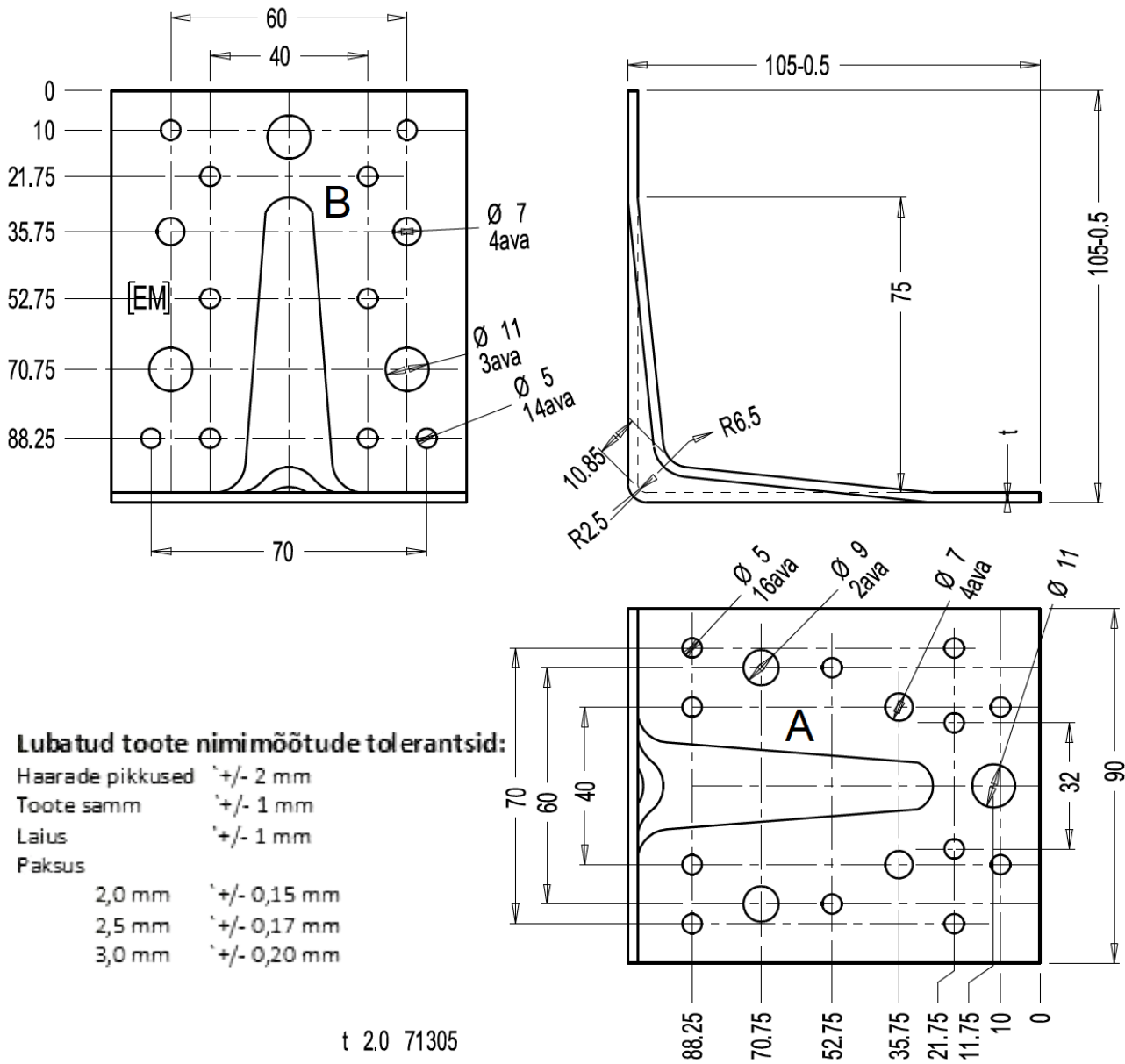
3.2 



Moterjol: HDG DX51D Z275 MAC				Arv: 1 tk.	Moss:	Mõõt: M1:1	A4
Konstruktor	R.K.		30.10.09	Ninetus: Nurgik 105x105x90 71305			
Kontrollis							
				Leht: 1	Tõhis: KR 217	Muudat. -XX	Tootekoort
				Lehti: 1			

3.2 

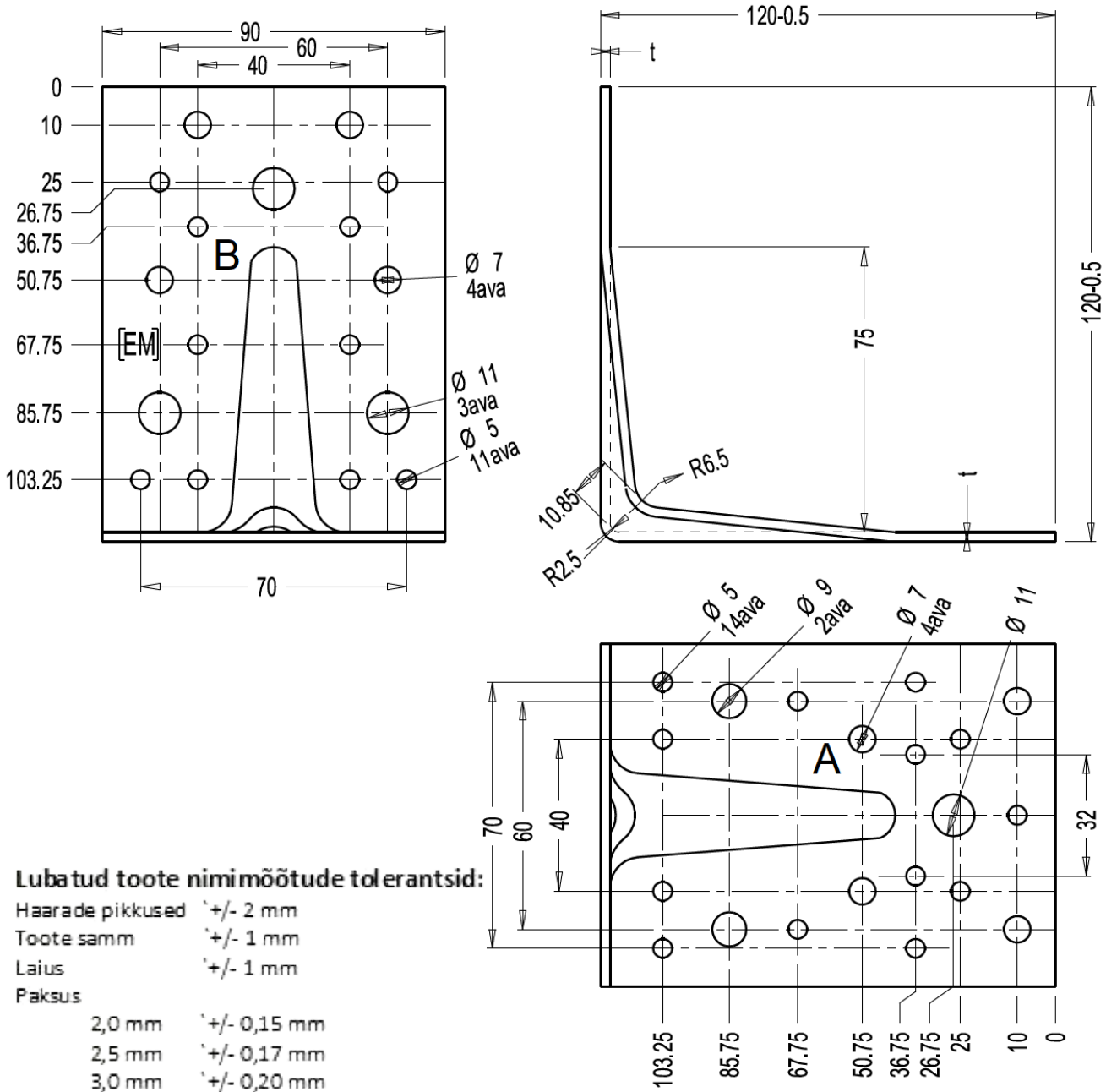

Lubatud toote nimimõõtude tolerantsid:

Haarade pikkused	± 2 mm
Toote samm	± 1 mm
Laius	± 1 mm
Paksus	
2,0 mm	$\pm 0,15$ mm
2,5 mm	$\pm 0,17$ mm
3,0 mm	$\pm 0,20$ mm

t 2.5 71306

Materjal: HDG DX51D Z275 MAC				Arv: 1 tk.	Moss:	Mõõt: M1:1	A4	
Konstruktor	R.K.		30.10.09	Ninetus: Nurgik 120x120x90 71306				
Kontrollis								
				Leht: 1	Tõhis: KR 217		Muudat. -XX	Tootekoart
				Lehti: 1				

3.2

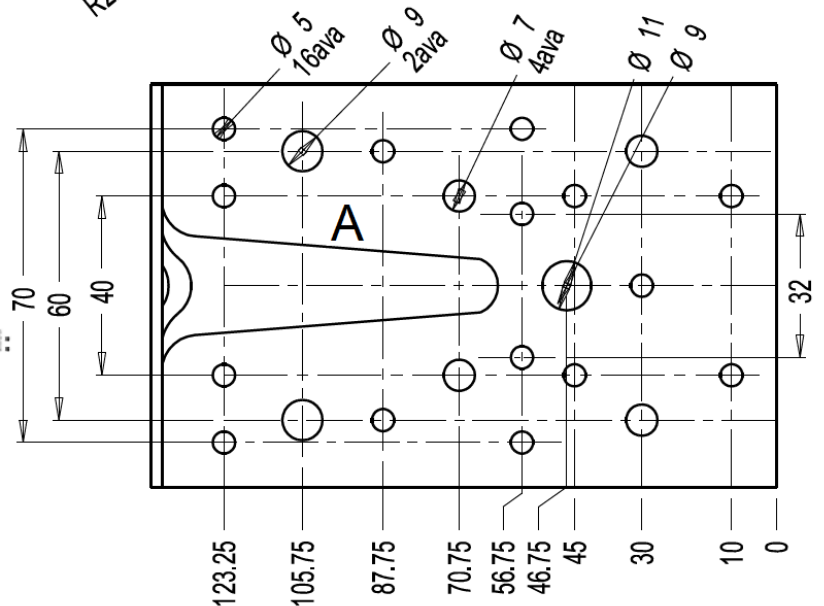
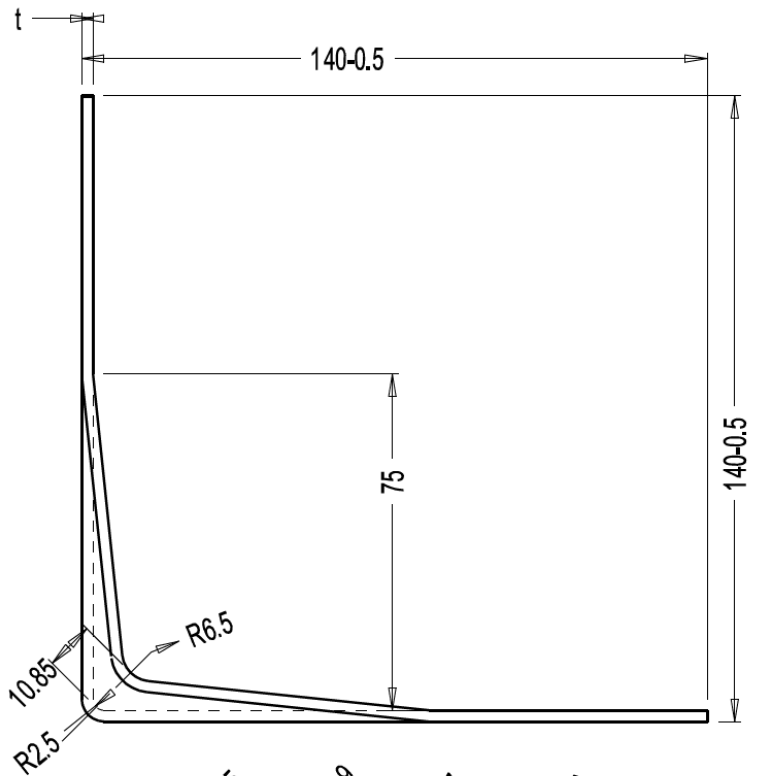
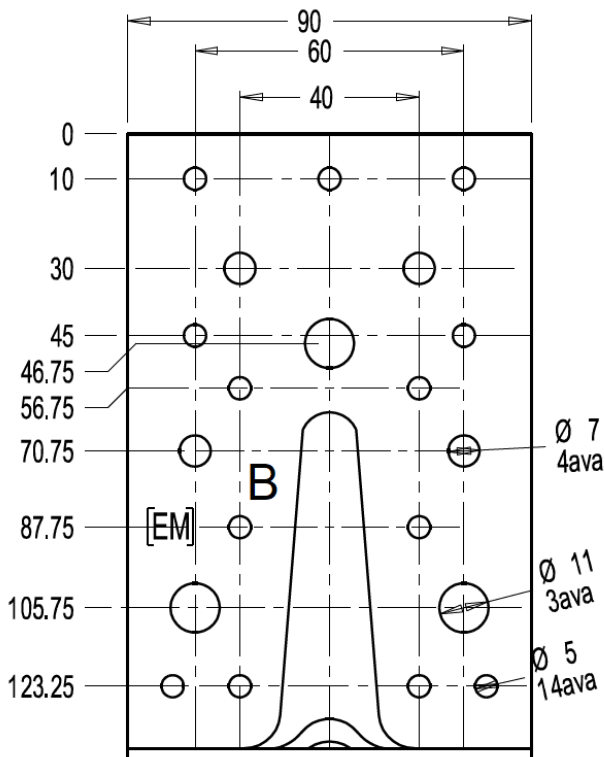

Lubatud toote nimiõõttude tolerantsid:

- Haarade pikkused +/- 2 mm
- Toote samm +/- 1 mm
- Laius +/- 1 mm
- Paksus
 - 2,0 mm +/- 0,15 mm
 - 2,5 mm +/- 0,17 mm
 - 3,0 mm +/- 0,20 mm

71307 t2.5

Materjal: HDG DX51D Z275 MAC				Arv: 1 tk.	Moss:	Mõõt: M1:1	A4
Konstruktor	R.K.	30.10.09	Ninetus: Nurgik 140x140x90 71307				
Kontrollis							
			Leht: 1	Tõhis: KR 217		Muudot. -XX	Tootekaart
			Lehti: 1				

3.2

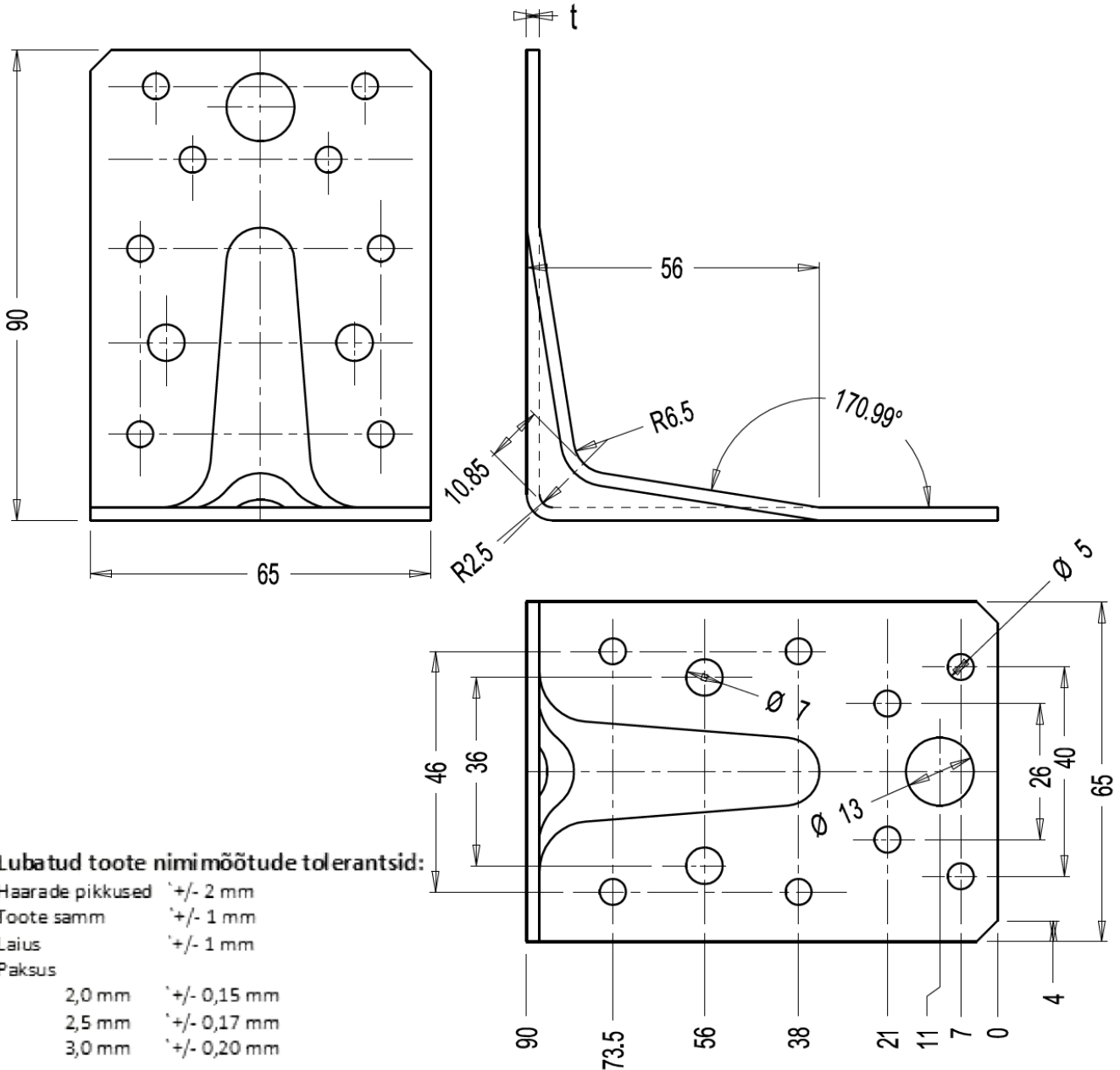

t 2,0 71308

Materjal: HDG DX 510 Z275 MAC				Arv: X tk.	Moss:	Mõõt: M1:1	A4
Konstruktor	R.K.		XX.XX.XX	Ninetus: Nurgik 90x90x65 71308			
Kontrollis							
			Leht: 1 Lehti: 1	Tõhis: KR 186		Muudot. -XX	Tootekoort

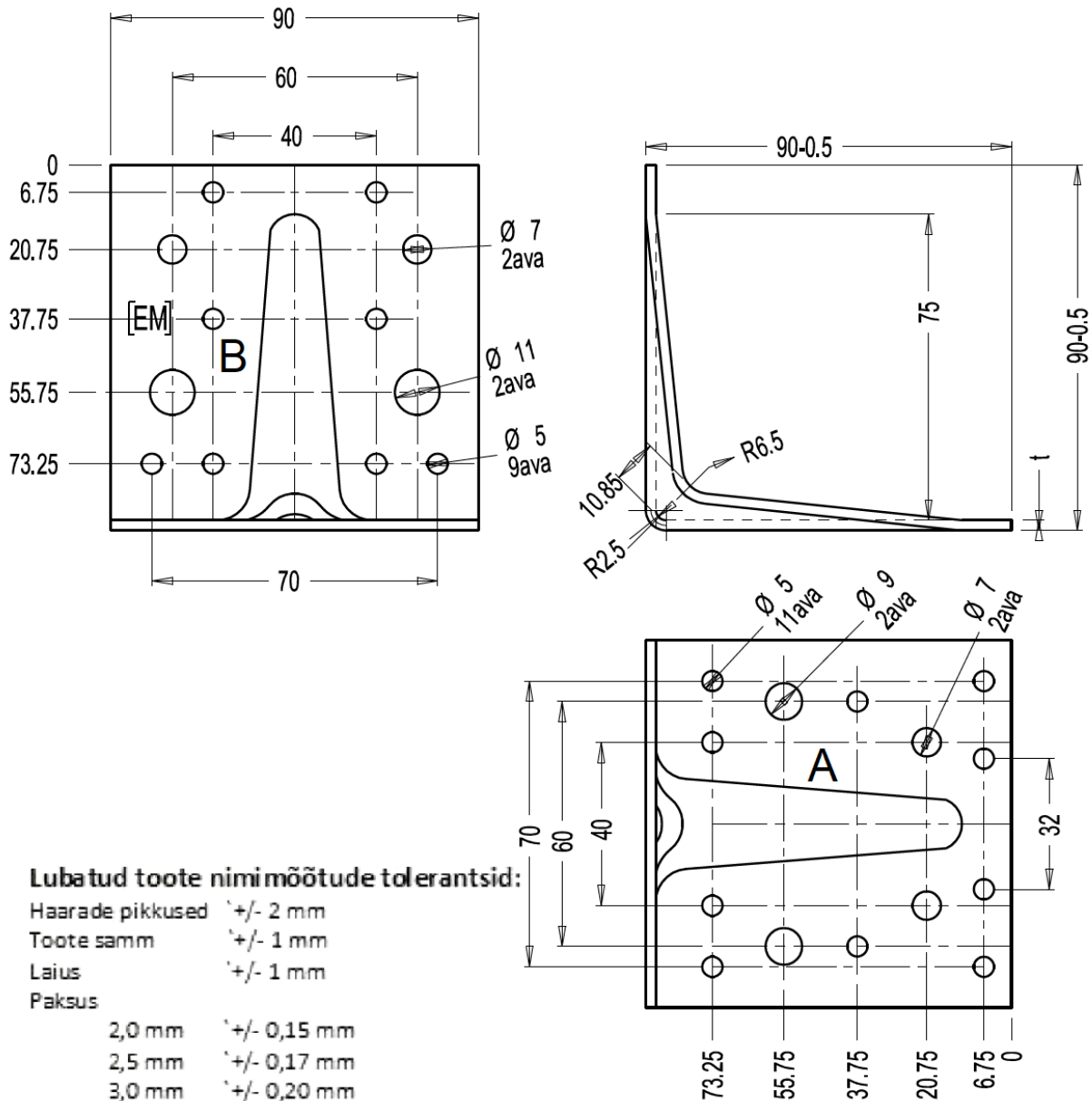
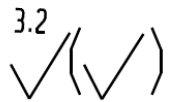

t 2,5 71311

Materjal: HDG DX51D Z275 MAC				Arv: 1 tk.	Moss:	Mõõt: M1:1	A4
Konstruktor	R.K.		30.10.09	Ninetus: Nurgik 90x90x90 71311			
Kontrollis							
			Leht: 1 Lehti: 1	Tõhis: KR 217	Muudot: -XX	Tootekoort	

3.2

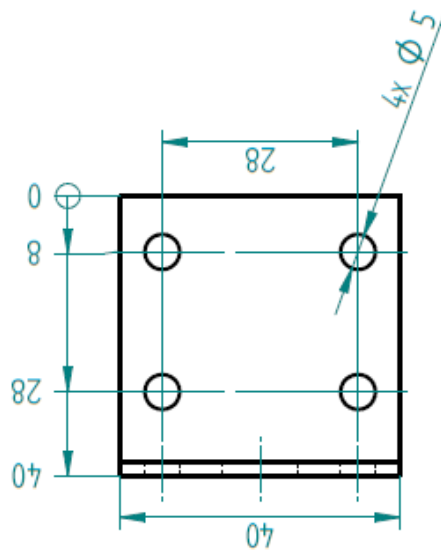
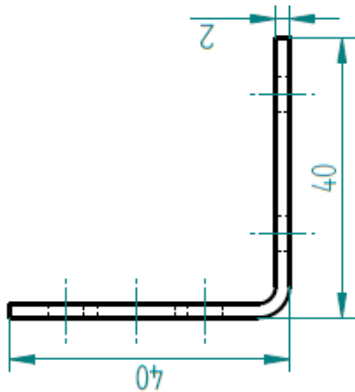
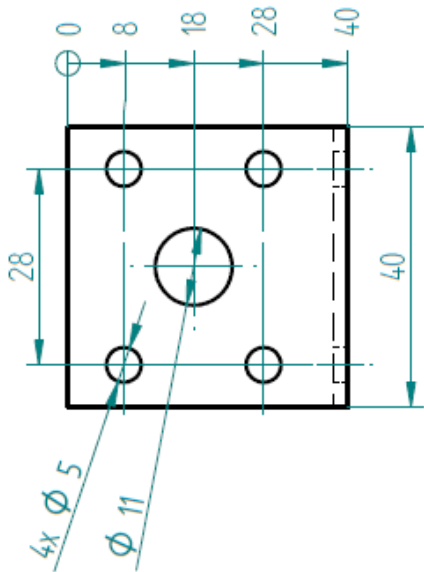
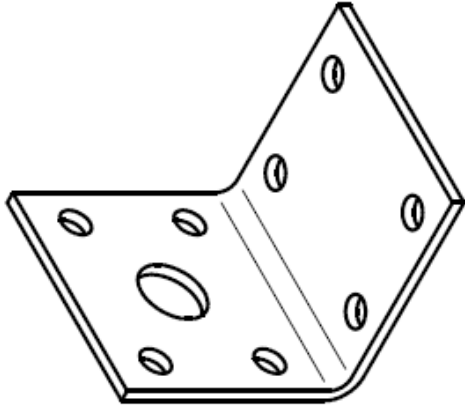

Lubatud toote nimimõõtude tolerantsid:

- Haarade pikkused ± 2 mm
- Toote samm ± 1 mm
- Laius ± 1 mm
- Avad $\pm 0,4$ mm

Nimetus:		Nurgik 40x40x40x2,0 11mm ava	
Materjal:	HDG DX 510 Z275		
Joonestaja:	M.R		
Kontrollis:		ART: 71320	
Kuupäev:	03.02.2021	Stants: KR-104	
		Skala:	1:1
		Kaal:	0,044 kg

3.2

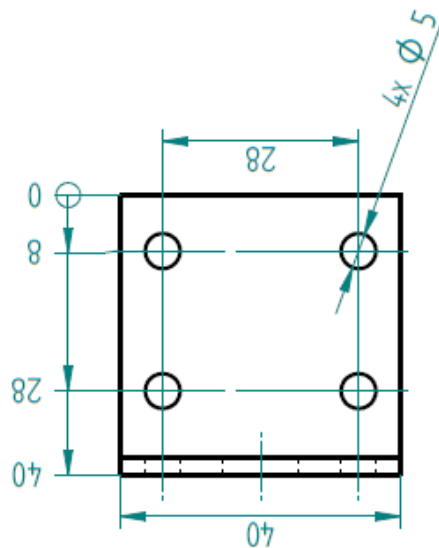
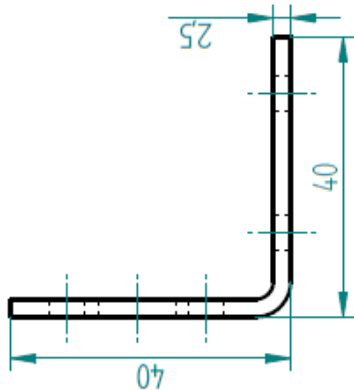
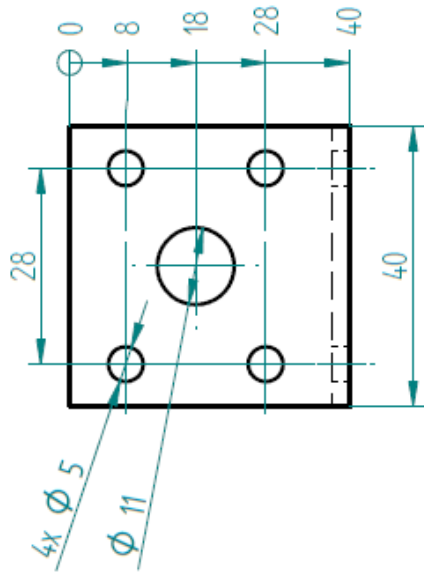
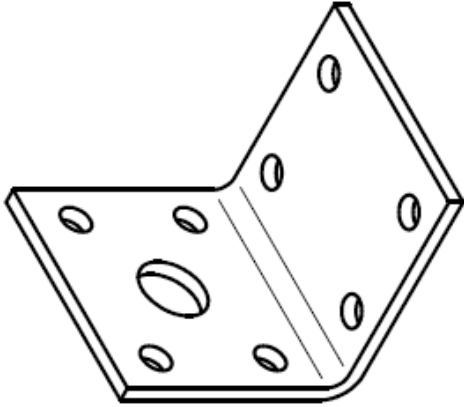

Lubatud toote nimimõõtude tolerantsid:

- Haarade pikkused ± 2 mm
- Toote samm ± 1 mm
- Laius ± 1 mm
- Avad $\pm 0,4$ mm

Nimetus:		Nurgik 40x40x40x2,5 11mm ava	
Materjal:	HDG DX 510 Z275		
Joonestaja:	M.R		
Kontrollis:		ART: 71321	
Kuupäev:	03.02.2021		
		Suurus	Starts: KR-104
		A4	
Skaala: 1:1		Kaal: 0,055 kg	

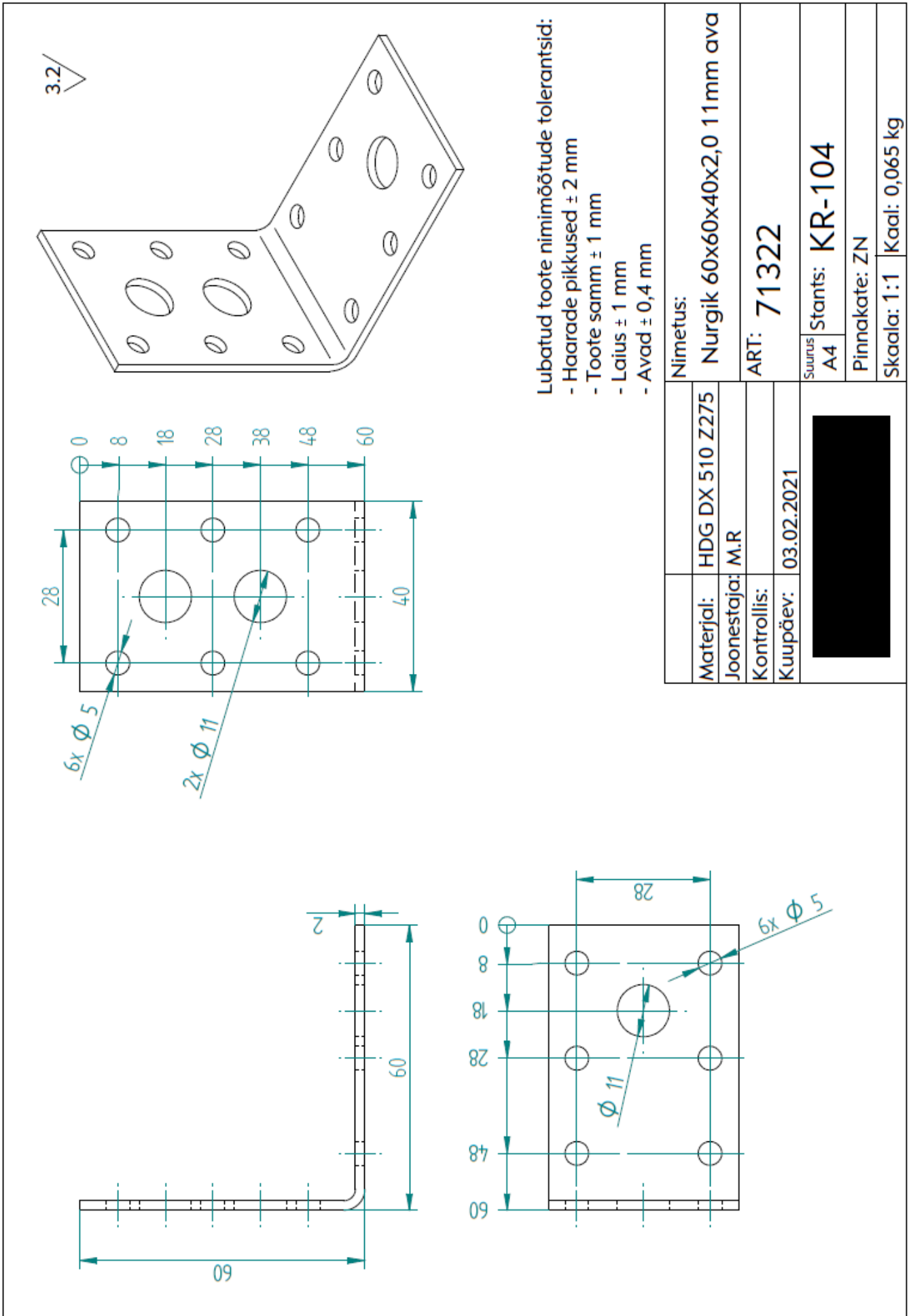

3.2/

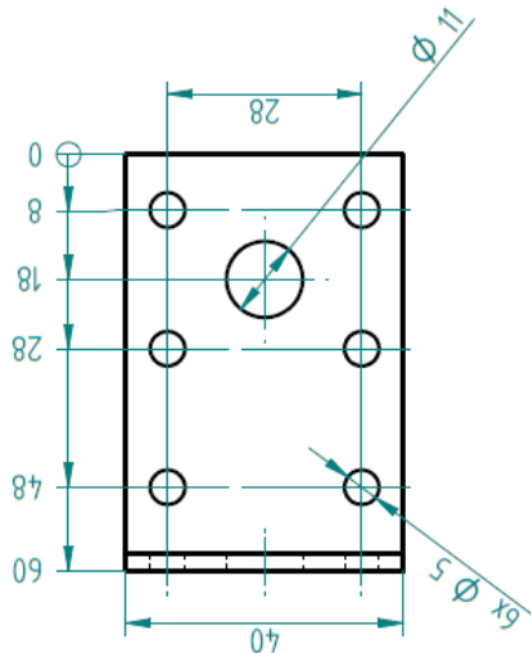
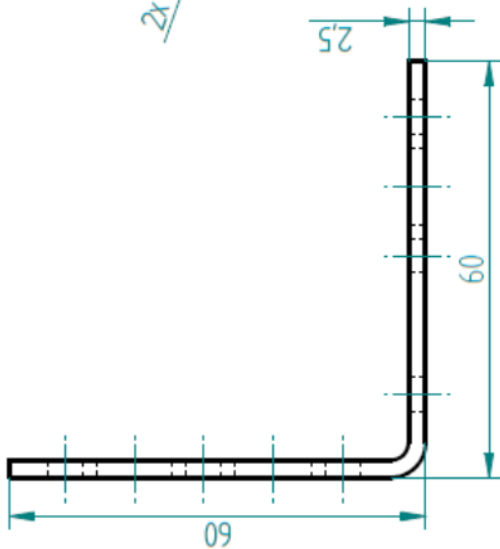
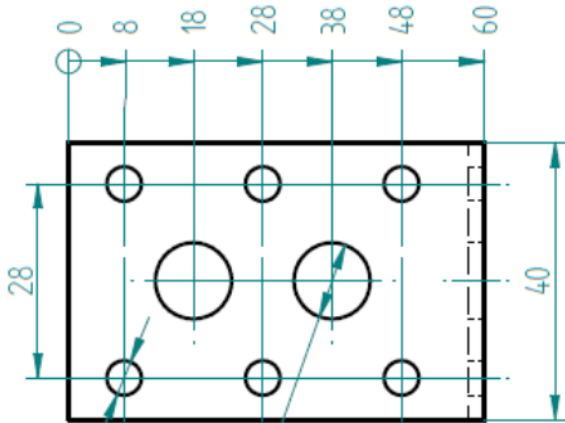
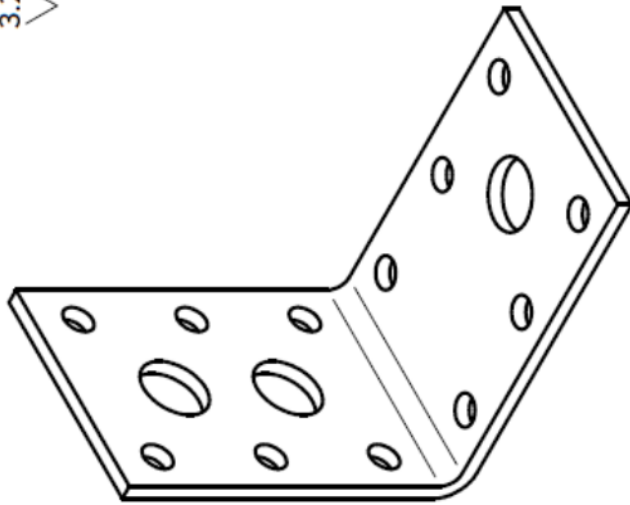

Lubatud toote nimimõõtude tolerantsid:

- Haarade pikkused ± 2 mm
- Toote samm ± 1 mm
- Laius ± 1 mm
- Avad $\pm 0,4$ mm

Nimetus:		Nurgik 60x60x40x2,5 11mm ava	
Materjal:	HDG DX 510 Z275		
Joonestaja:	M.R		
Kontrollis:		ART: 71323	
Kuupäev:	03.02.2021	Suurus A4	
		Starts: KR-104	
		Skaala: 1:1	Kaal: 0,081 kg

3.2

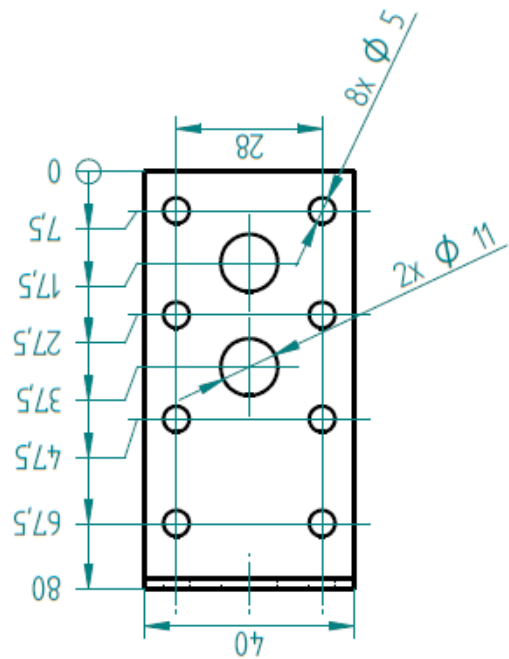
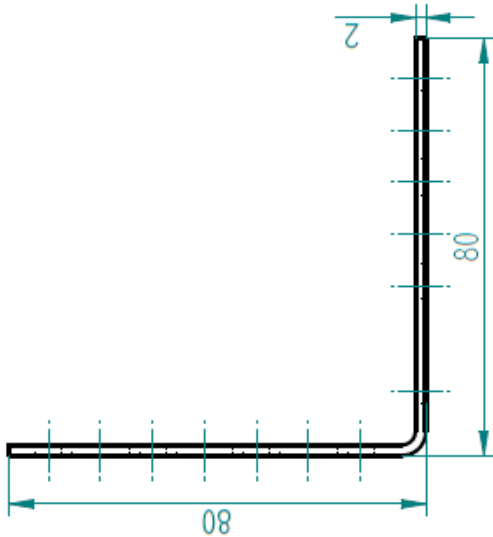
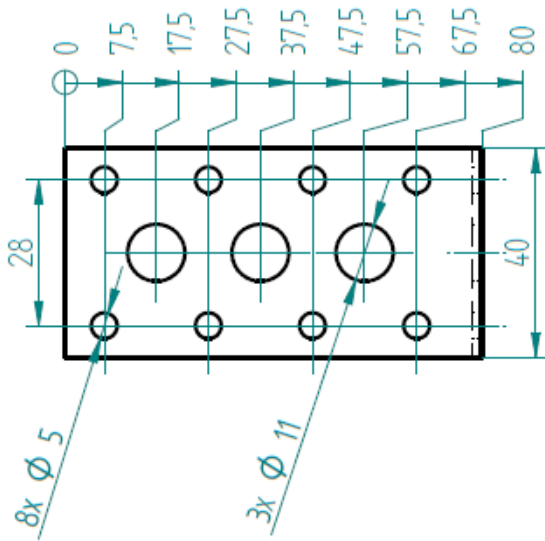
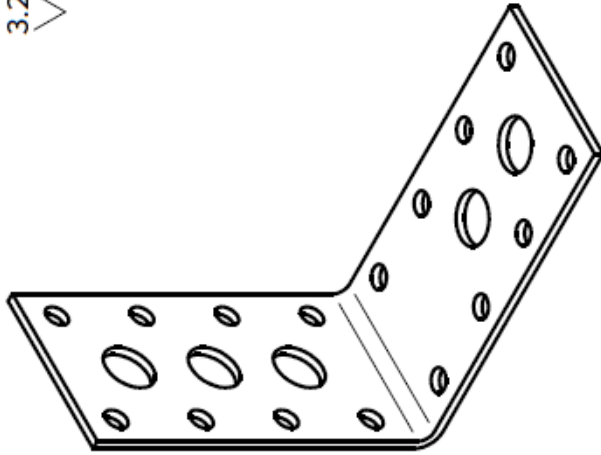

Lubatud toote nimimõõtude tolerantsid:

- Haarade pikkused ± 2 mm
- Toote samm ± 1 mm
- Laius ± 1 mm
- Avad ± 0,4 mm

Nimetus:		Nurgik 80x80x40x2,0 11mm ava	
Materjal:	HDG DX 510 Z275		
Joonestaja:	M.R		
Kontrollis:			
Kuupäev:	03.02.2021		
		Stants:	KR-104
		Skala:	1:1 Kaal: 0,086 kg

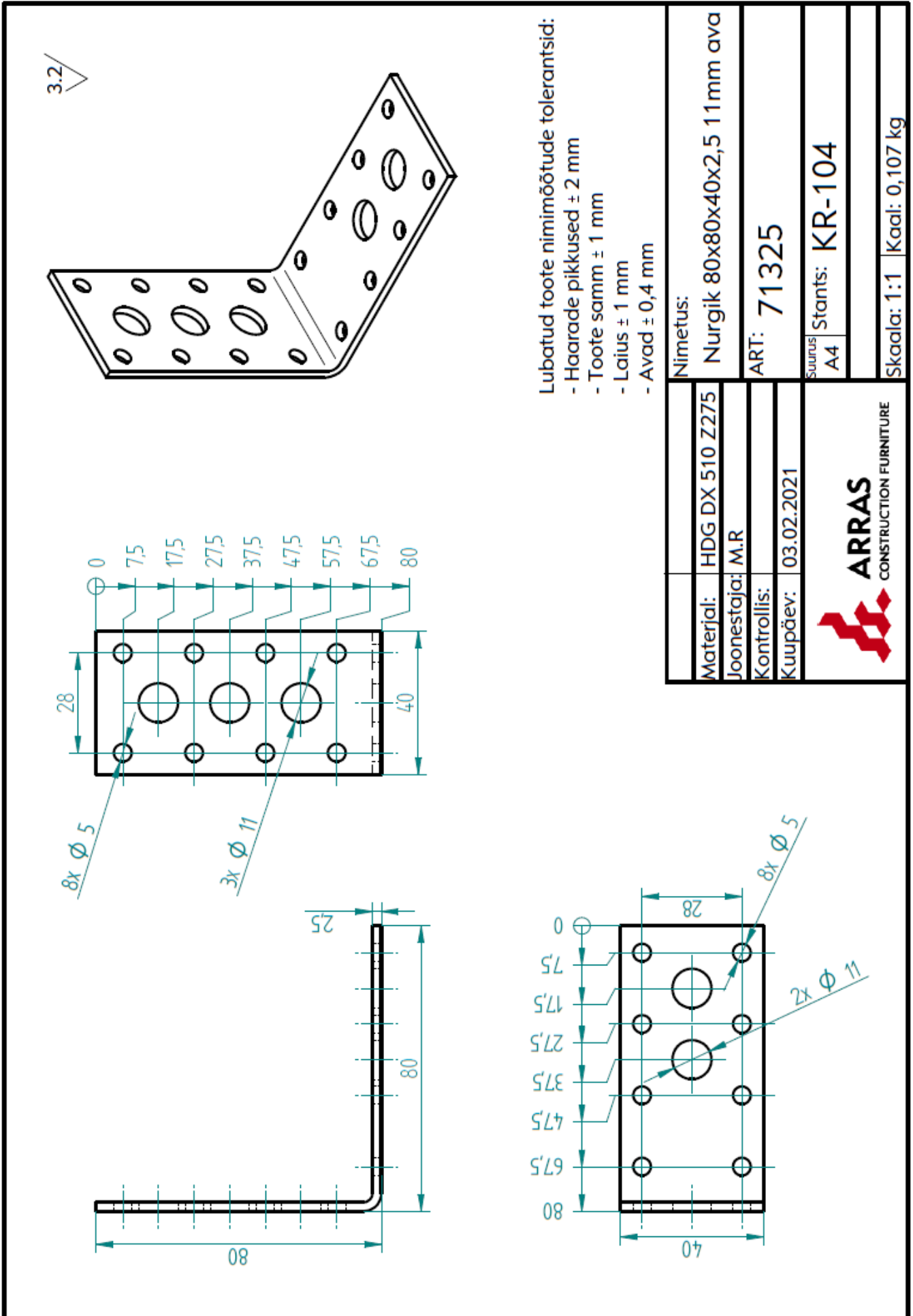

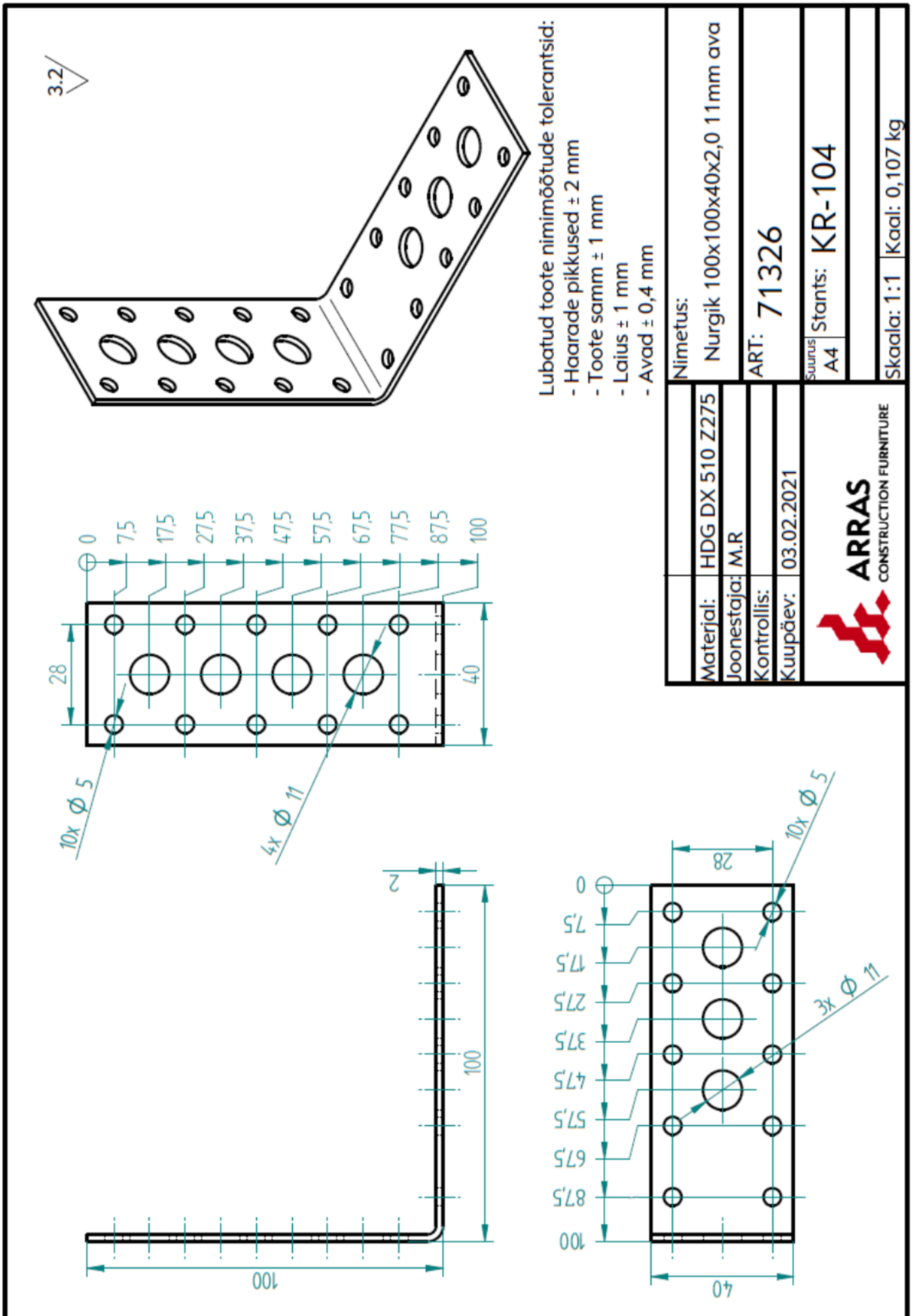

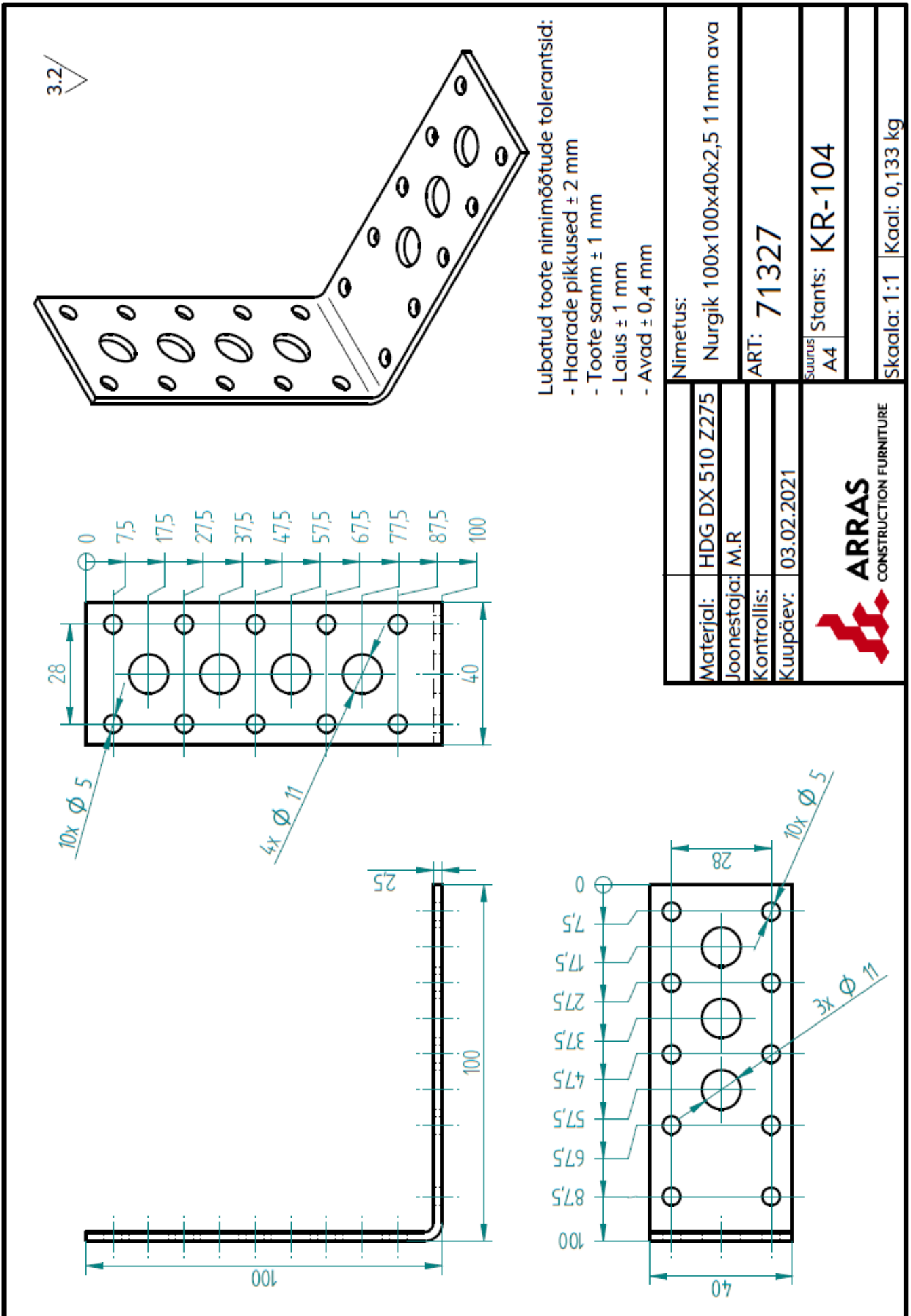

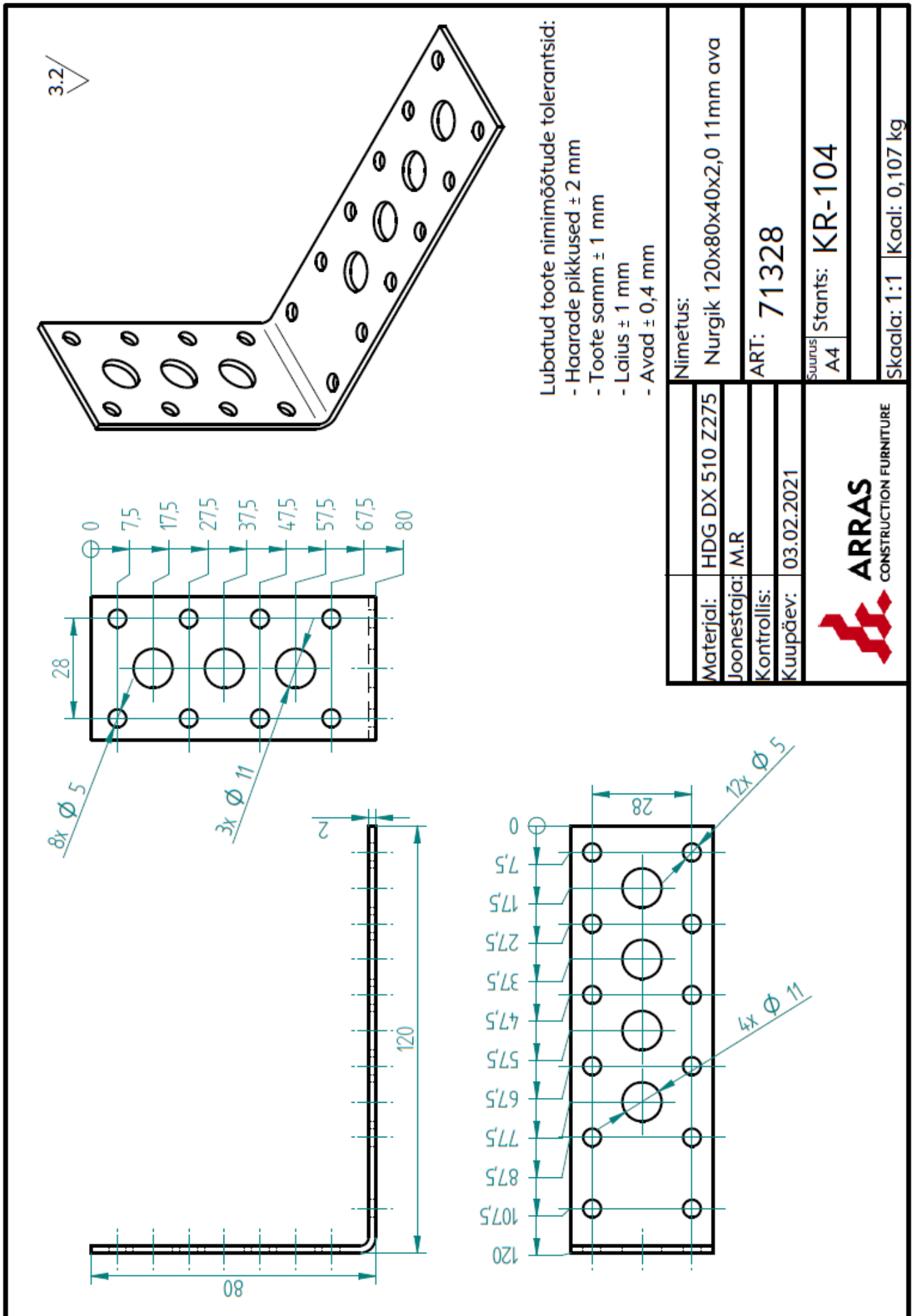

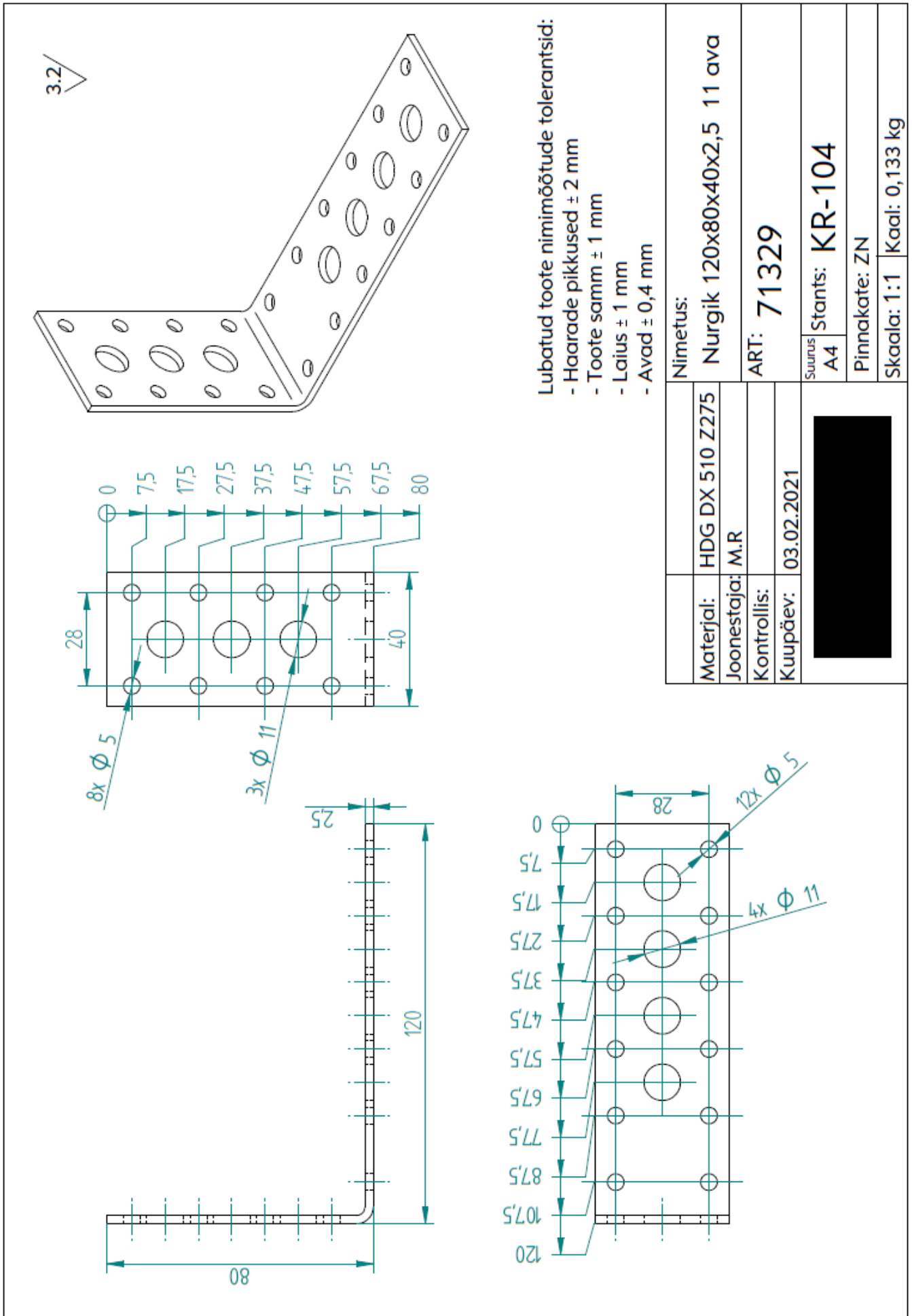

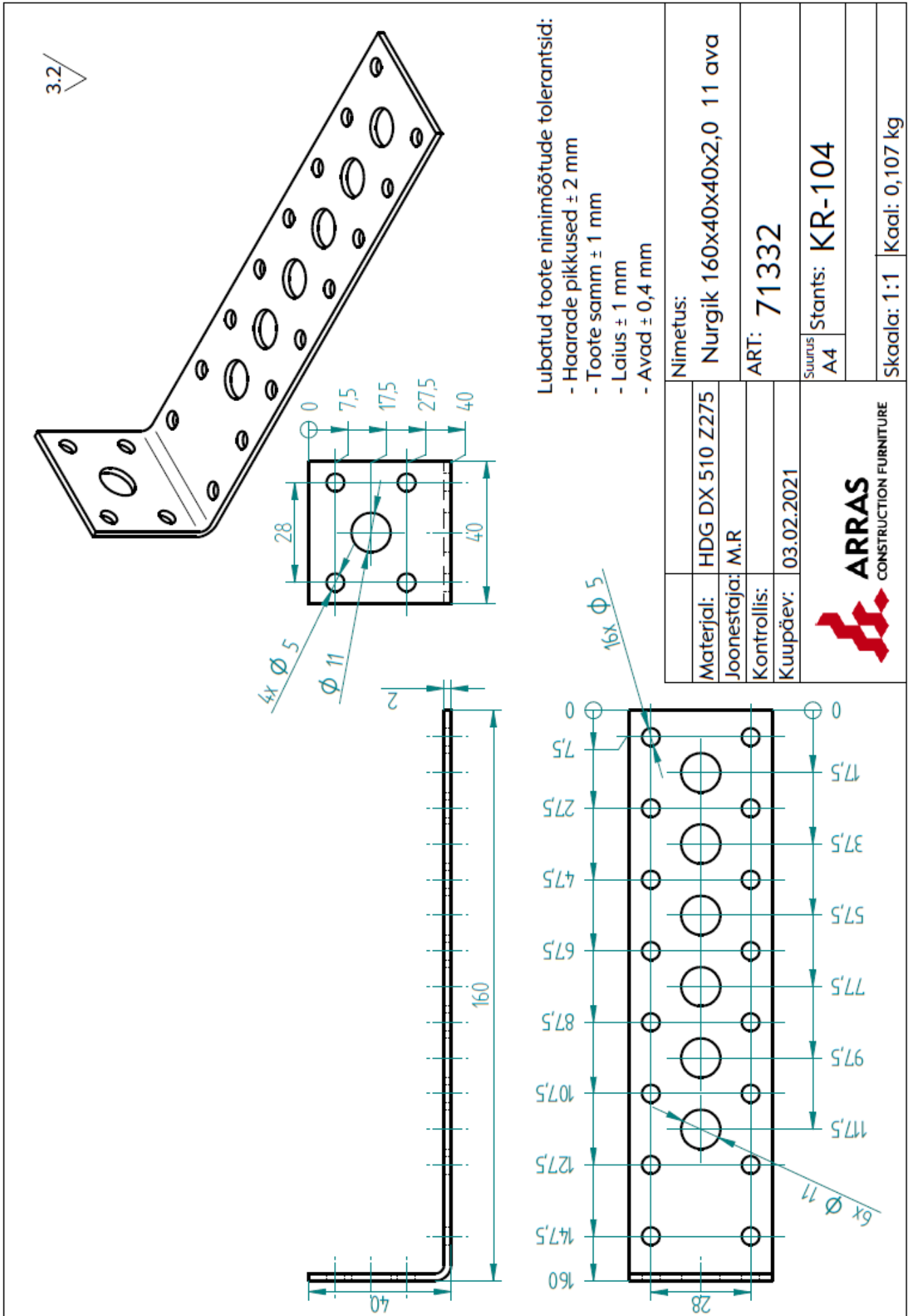

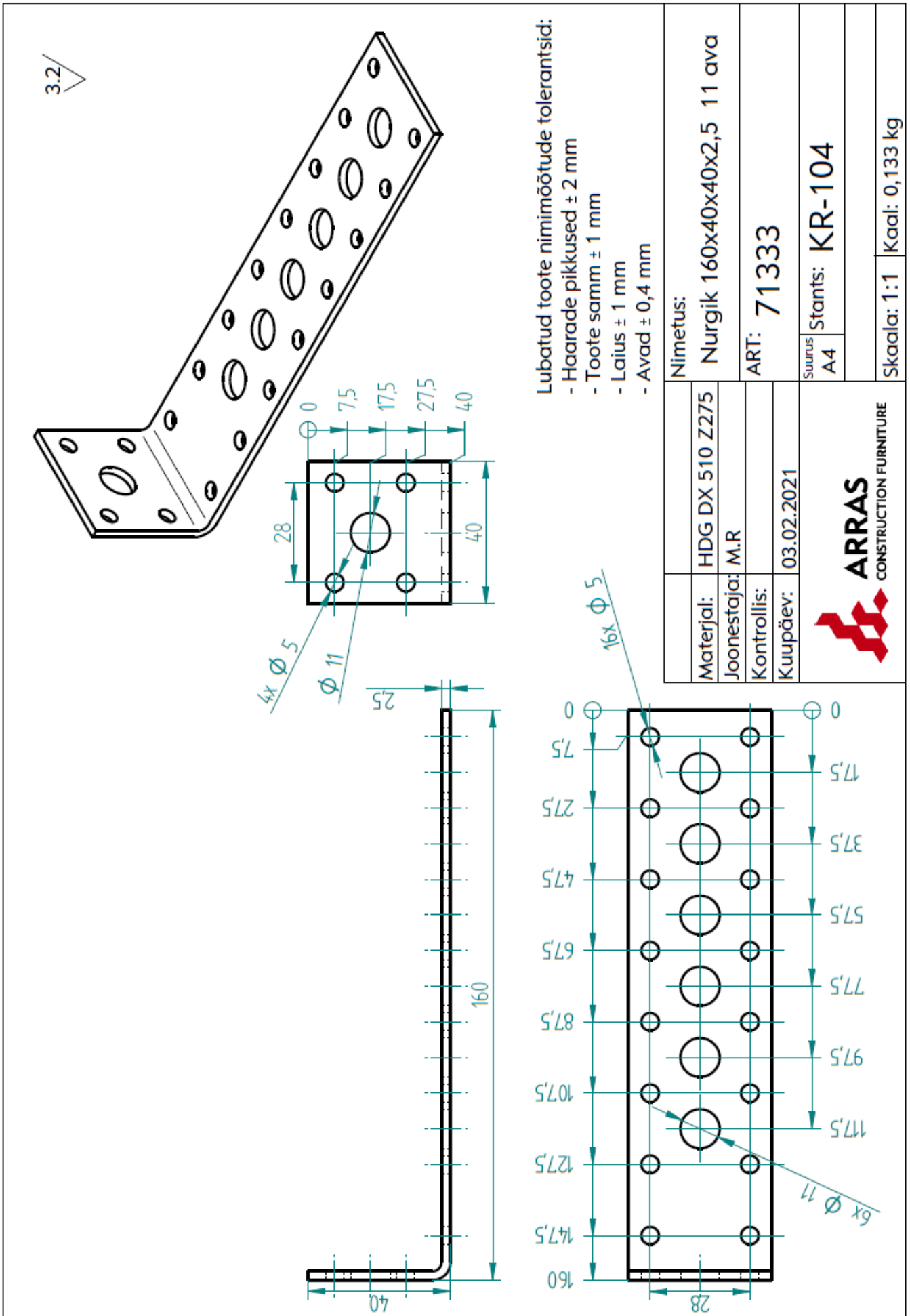



Lubatud toote nimimõõtude tolerantsid:

- Haarade pikkused ± 2 mm
- Toote samm ± 1 mm
- Laius ± 1 mm
- Avad $\pm 0,4$ mm

Materjal:	HDG DX 510 Z275	Nimetus:	Nurgik 160x40x40x2,5 11 ava
Joonestaja:	M.R	ART:	71333
Kontrollis:		Suurus	A4
Kuupäev:	03.02.2021	Stants:	KR-104
		Skaala:	1:1
		Kaal:	0,133 kg

3.2

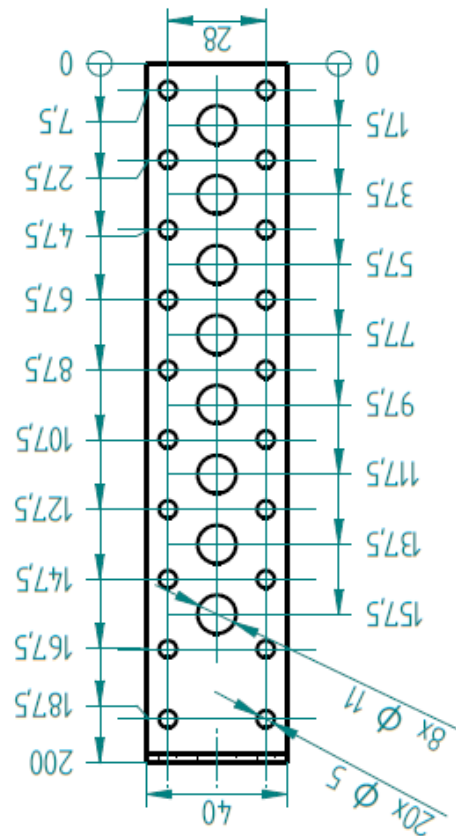
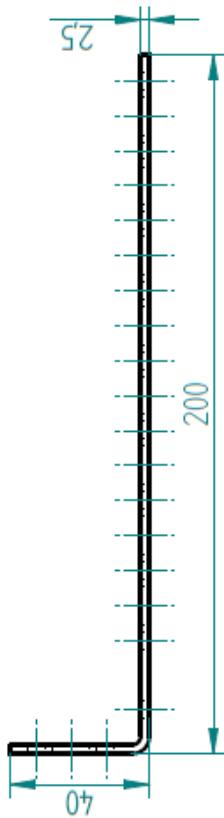
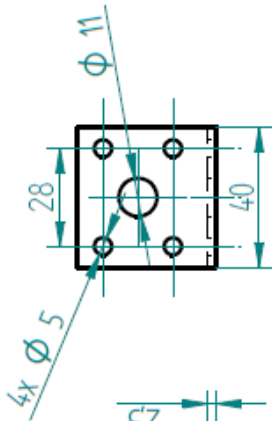
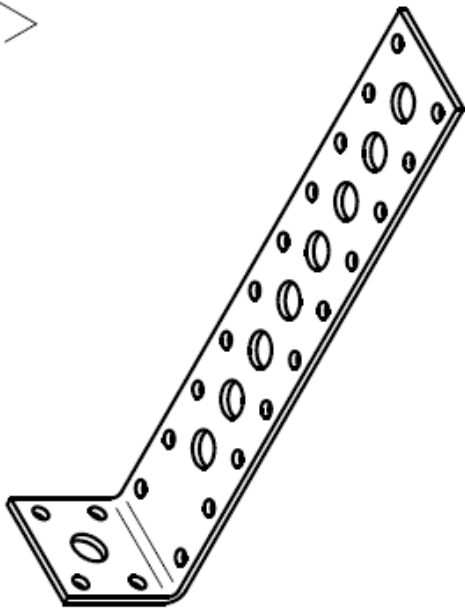

Lubatud toote nimimõõtude tolerantsid:

- Haarade pikkused ± 2 mm
- Toote samm ± 1 mm
- Laius ± 1 mm
- Avad ± 0,4 mm

Materjal:	HDG DX 510 Z275	Nimetus:	Nurgik 200x40x40x2,5 11mm ava
Joonestaja:	M.R	ART:	71335
Kontrollis:		Suurus	A4
Kuupäev:	03.02.2021	Stants:	KR-104
		Skala: 1:2	
		Kaal: 0,159 kg	

3.2

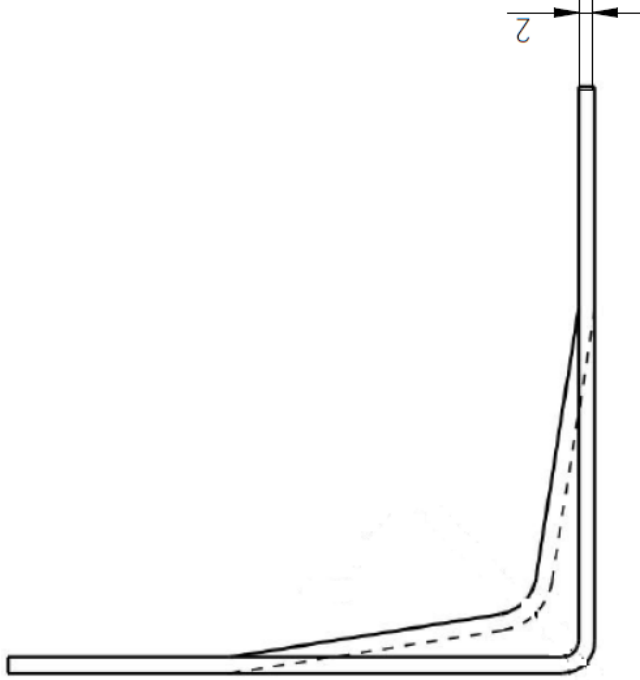
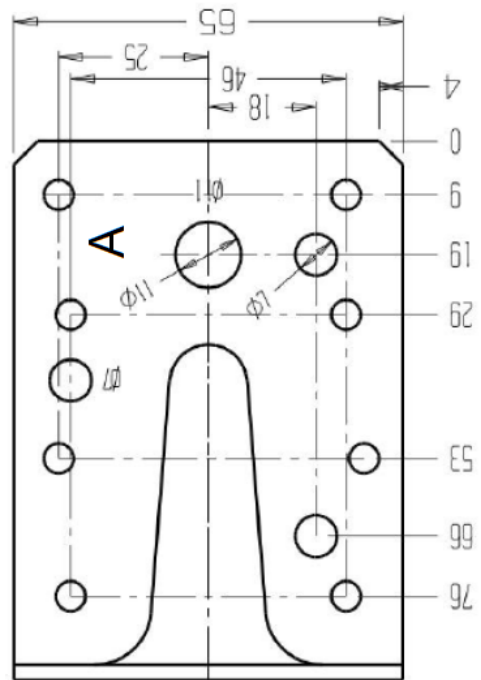
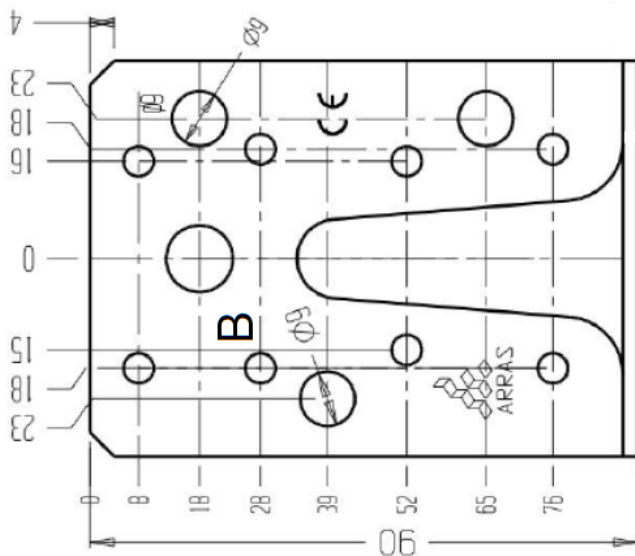

Lubatud toote nimimõõtude tolerantsid:

- Haarade pikkused ± 2 mm
- Toote samm ± 1 mm
- Laius ± 1 mm
- Avad $\pm 0,4$ mm

Materjal:	HDG DX 510 Z275	Nimetus:	Nurgik 90x90x65x2,0 tug.		
Joonestaja:	M.R.	Artikkel:	71340	Stants:	TT-001
Kontrollis:		Kuupäev:	11.12.2020	Lehe mõõt A4	
			Mõõt:	1:2	Kaal: 0,205 kg
			Leht: 1/1		

3.2

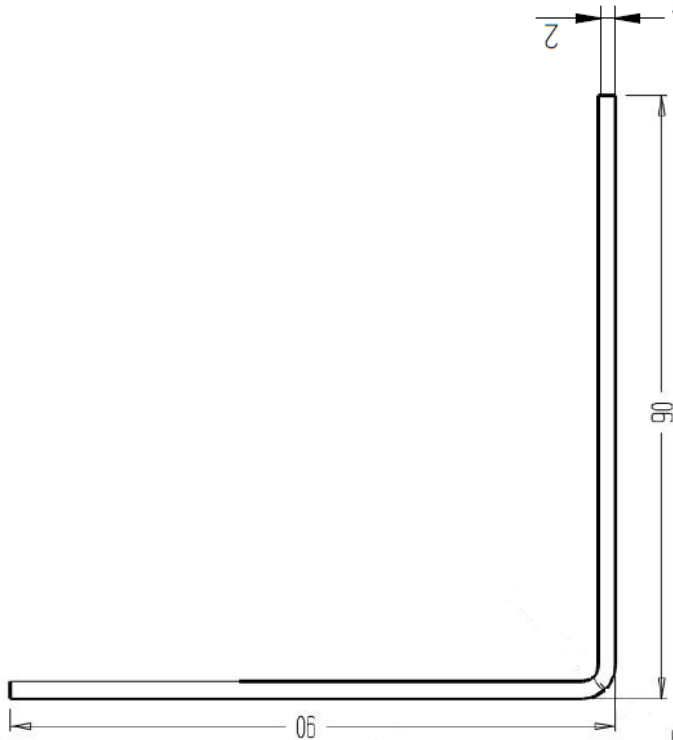
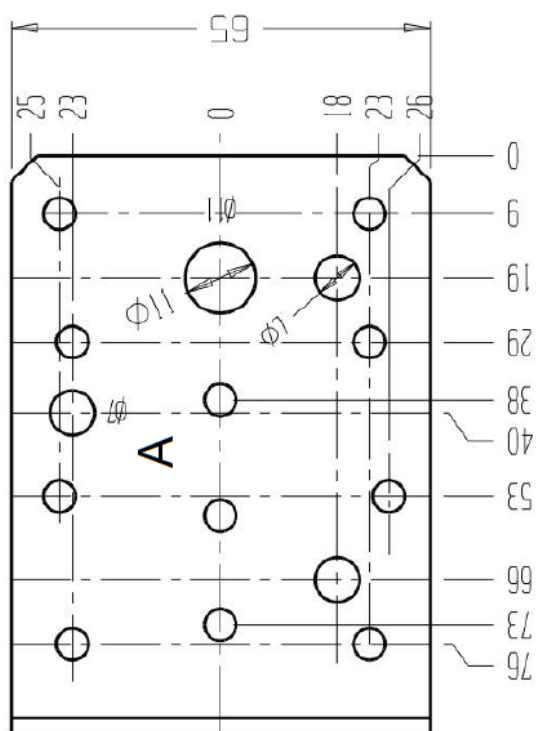
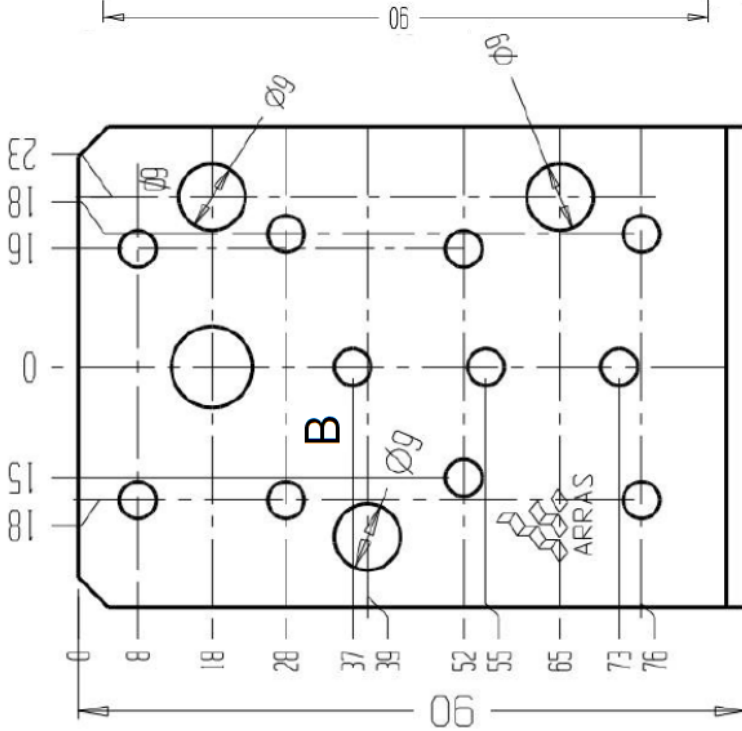

Lubatud toote nimimõõtude tolerantsid:
 - Haarade pikkused ± 2 mm
 - Toote samm ± 1 mm
 - Laius ± 1 mm
 - Avad $\pm 0,4$ mm

Materjal: HDG DX 510 Z275	Nimetus: Nurgik 90x90x65x2,0	Mööd: 1:2	Kaal: 0,205 kg	Leht: 1/1
Joonestaja: M.R.	Artikkel: 71345	Lehe mөөd A4		
Kontrollis: 11.12.2020	Starts: TT-001			
Kuupäev:				
				

3.2

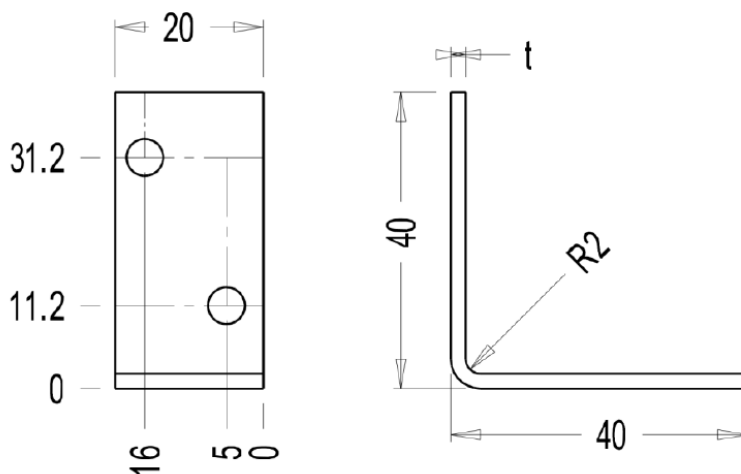

Lubatud toote nimimõõtude tolerantsid:

Haarade pikkused ± 2 mm

Toote samm ± 1 mm

Laius ± 1 mm

Paksus

2,0 mm $\pm 0,15$ mm

2,5 mm $\pm 0,17$ mm

3,0 mm $\pm 0,20$ mm

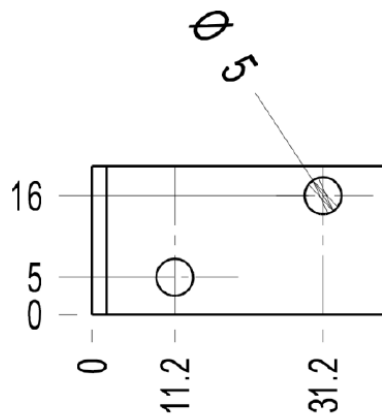

t 2.0 71402

Materjal: HDG DX 510 Z275 MAC				Arv: X tk.	Moss:	Mõõt: M1:1	A4
Konstruktor	R.K.		2.04.11	Ninetus: Nurgik 40x40x20 71402			
Kontrollis							
				Leht: 1	Tähis: KR 225		Muudat. Tootekaart
				Lehti: 1	-XX		

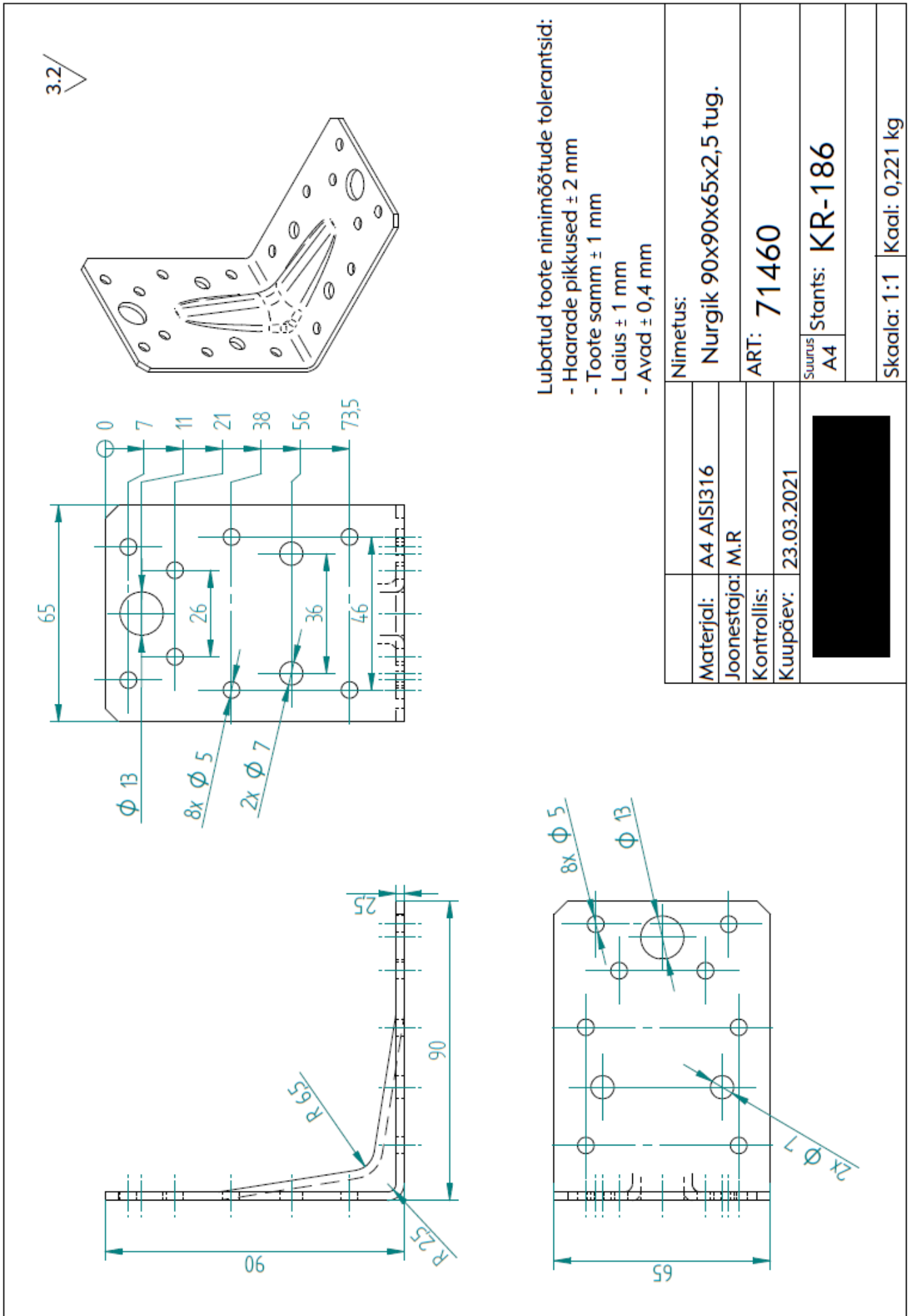

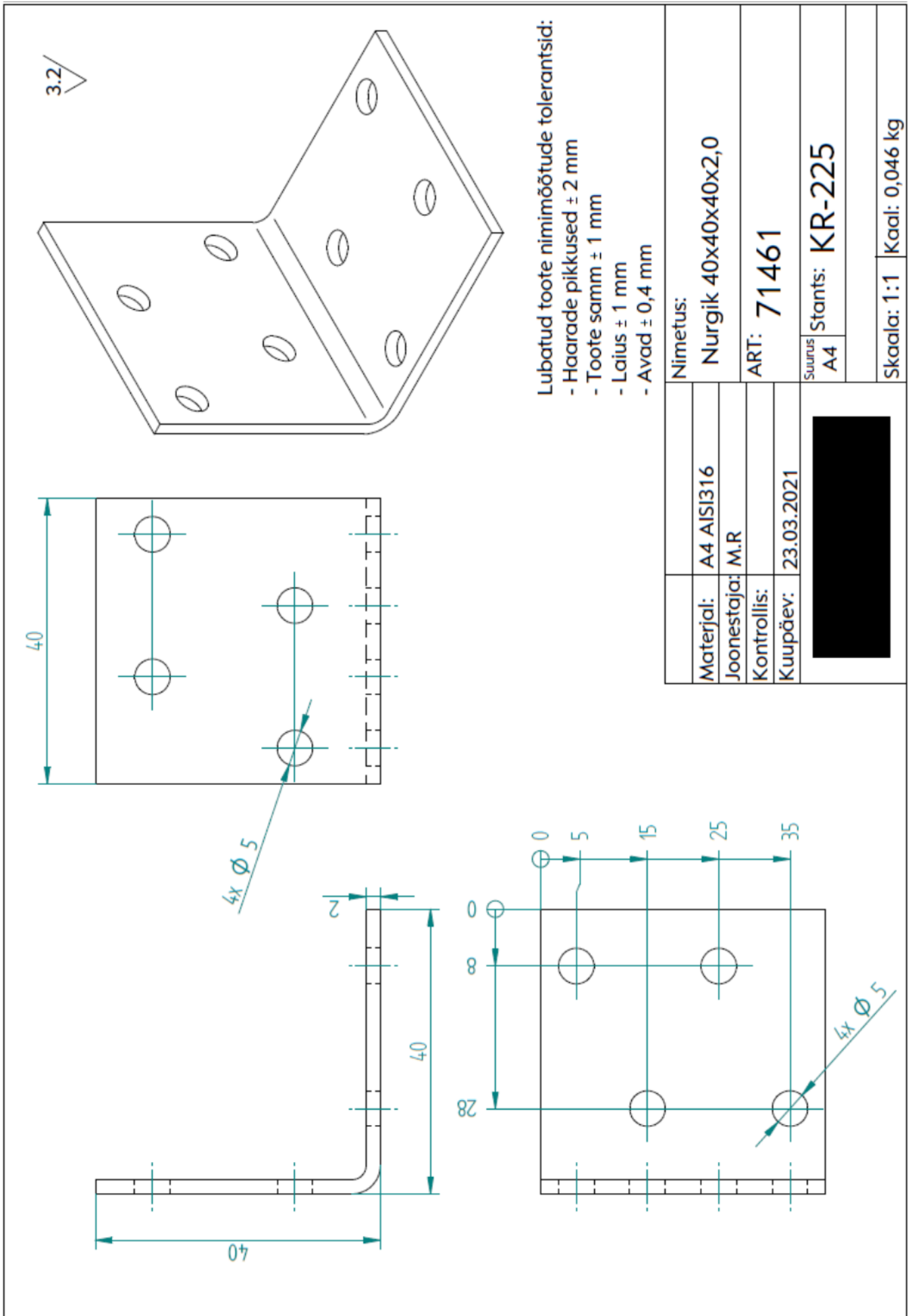

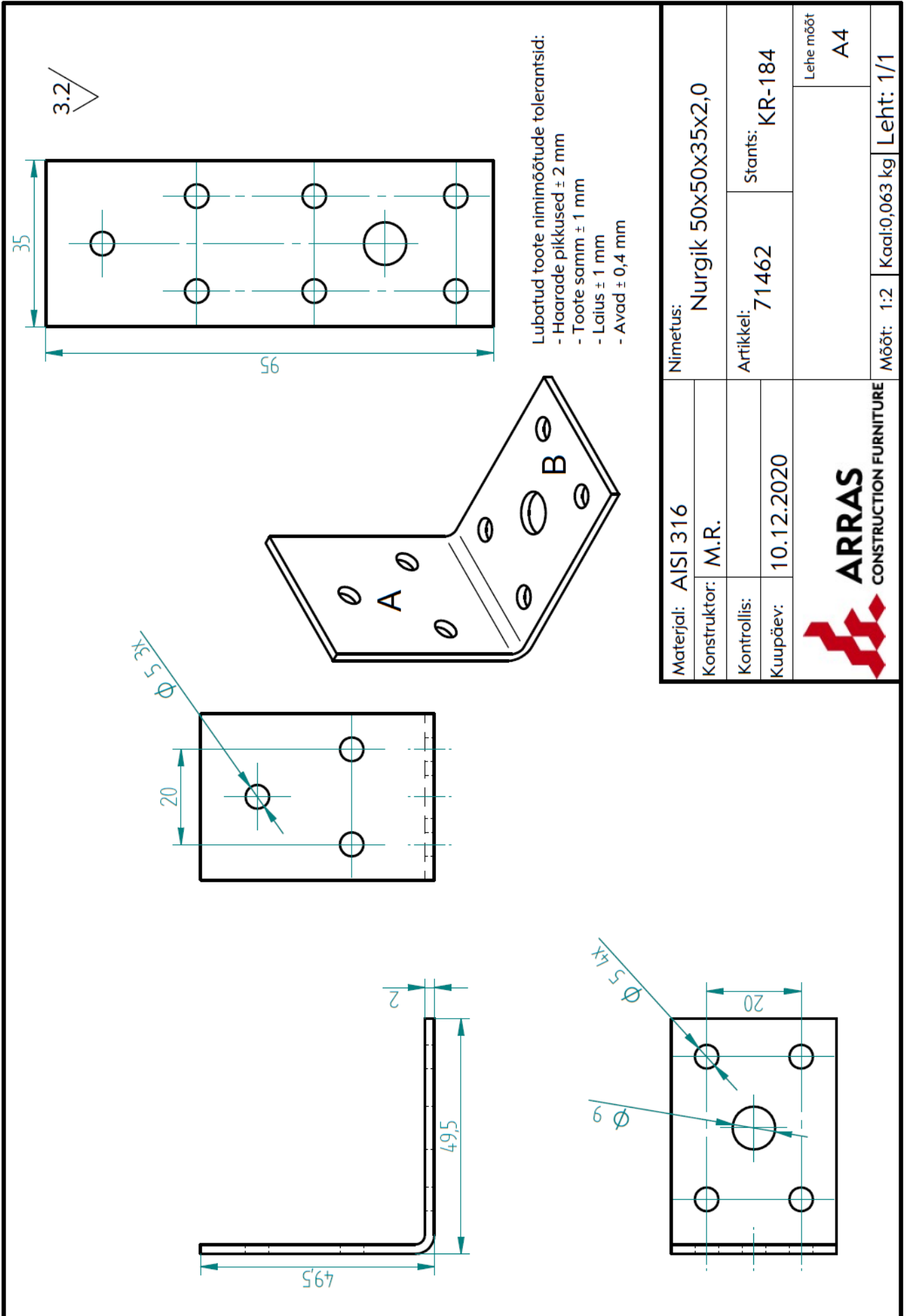

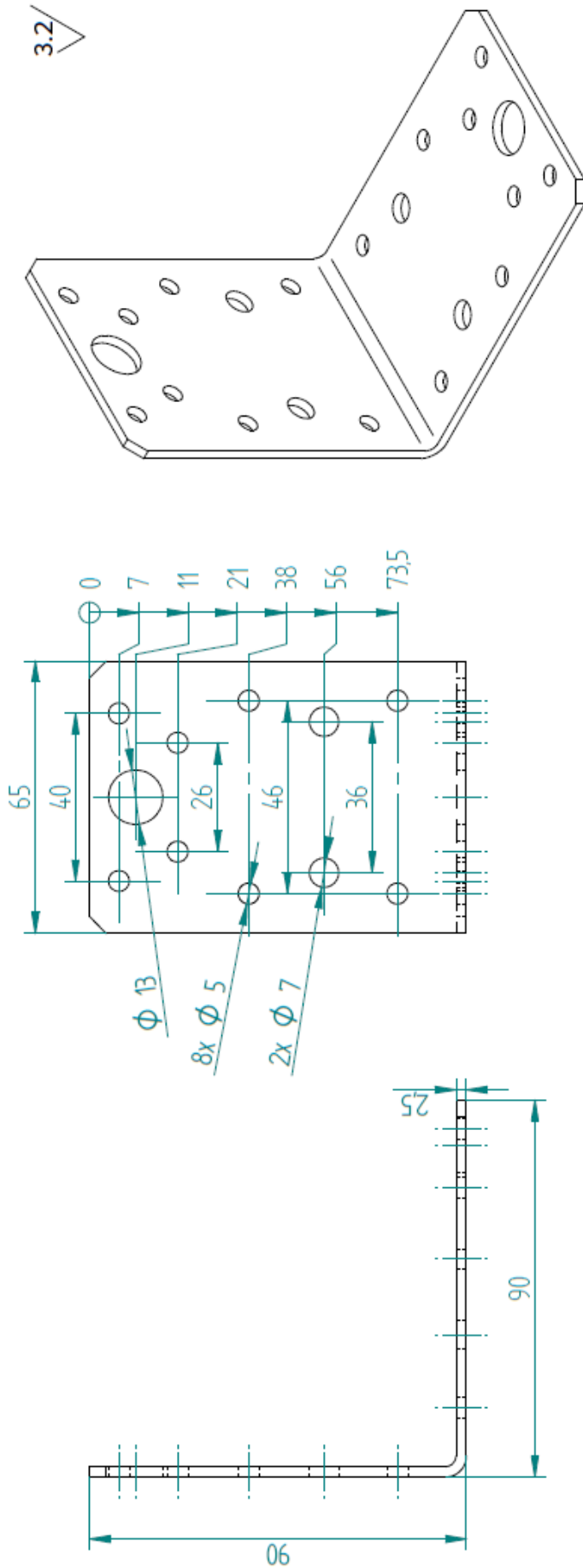

Lubatud toote nimimõõtude tolerantsid:

- Haarade pikkused ± 2 mm
- Toote samm ± 1 mm
- Laius ± 1 mm
- Avad $\pm 0,4$ mm

Materjal:	A4 AISI316	Nimetus:	Nurgik 90x90x65x2,5
Joonestaja:	M.R	ART:	71463
Kontrollis:		Suurus	A4
Kuupäev:	28.01.2021	Starts:	KR-186
		Skaala:	1:1
		Kaal:	0,209 kg

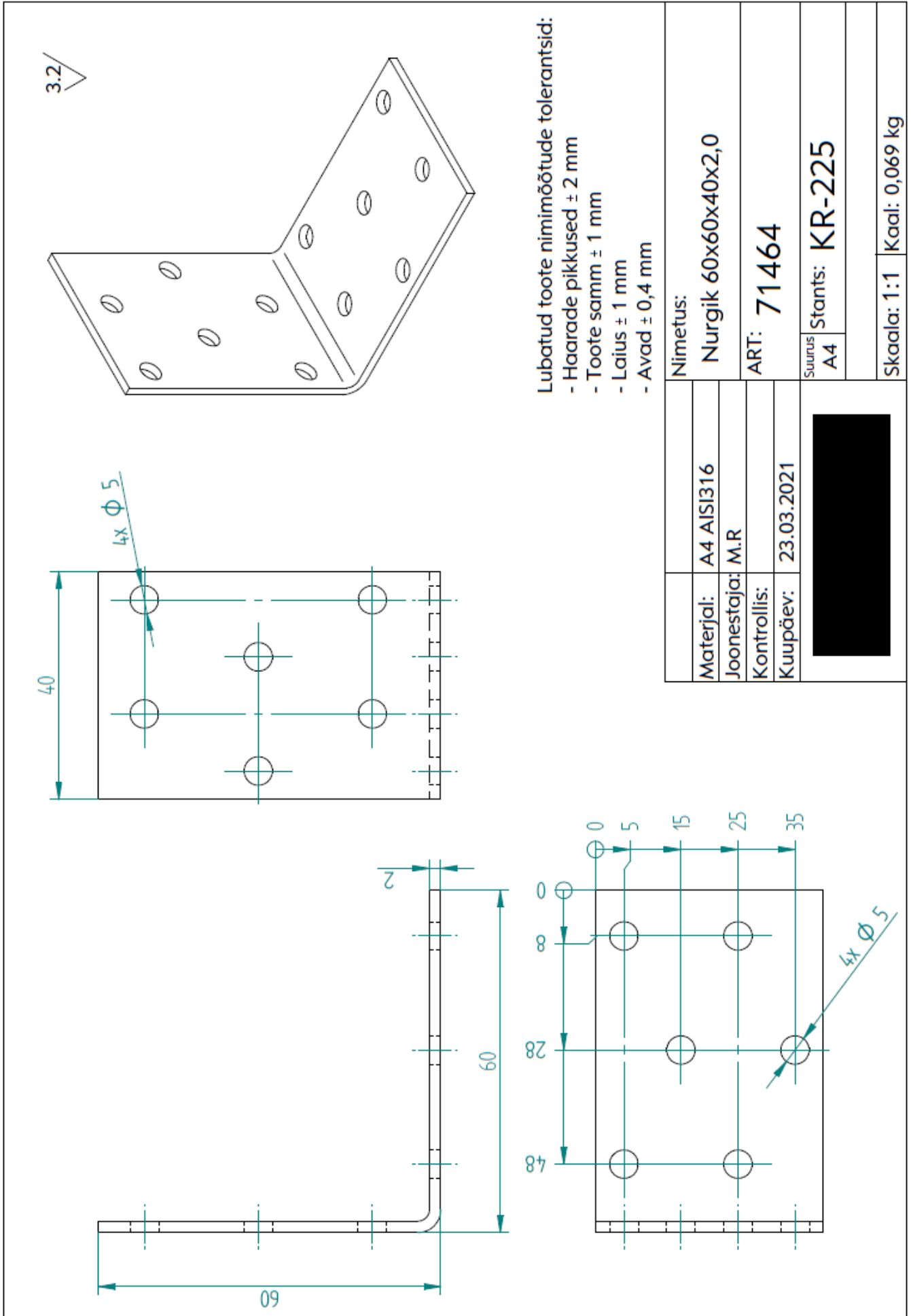

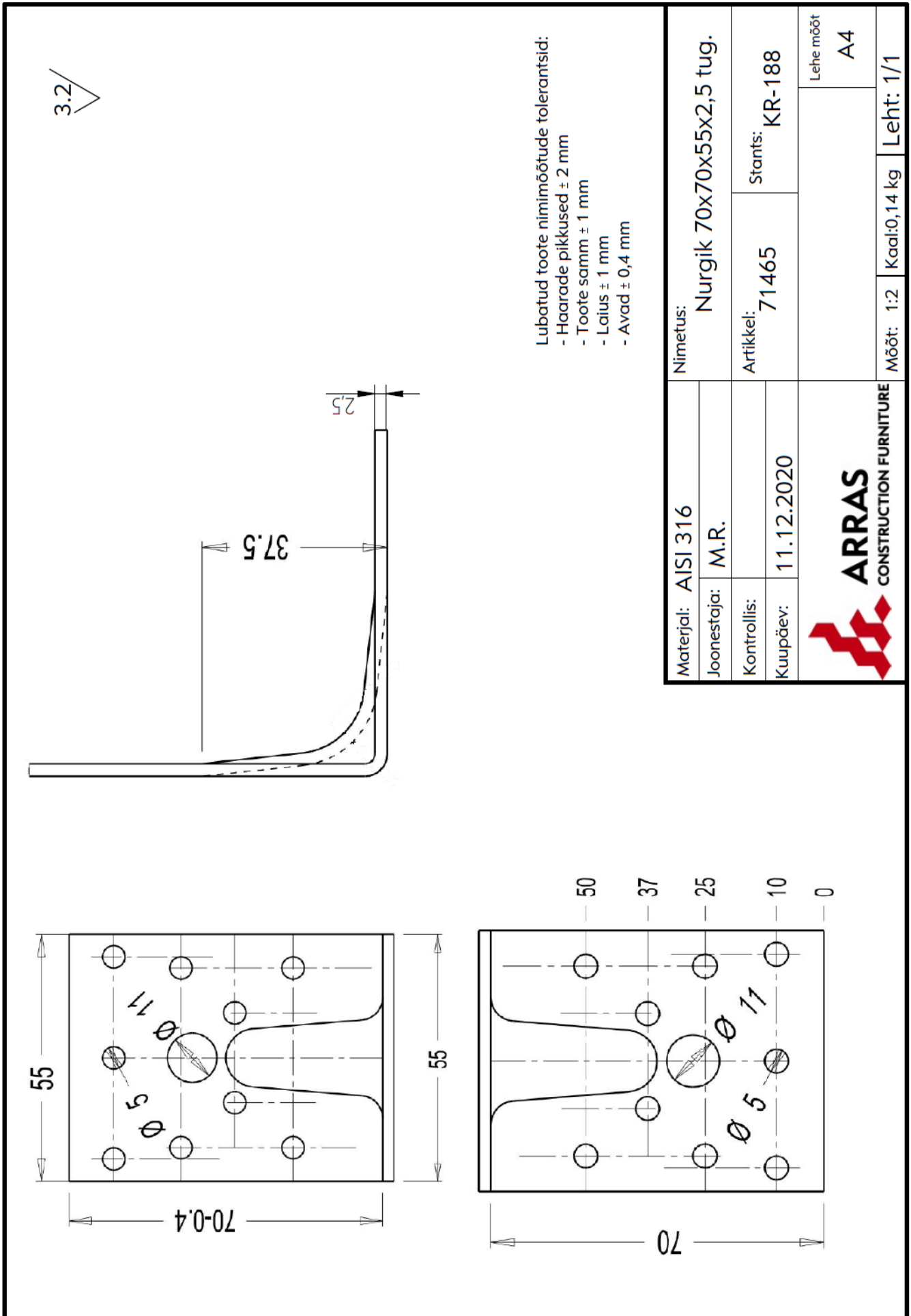

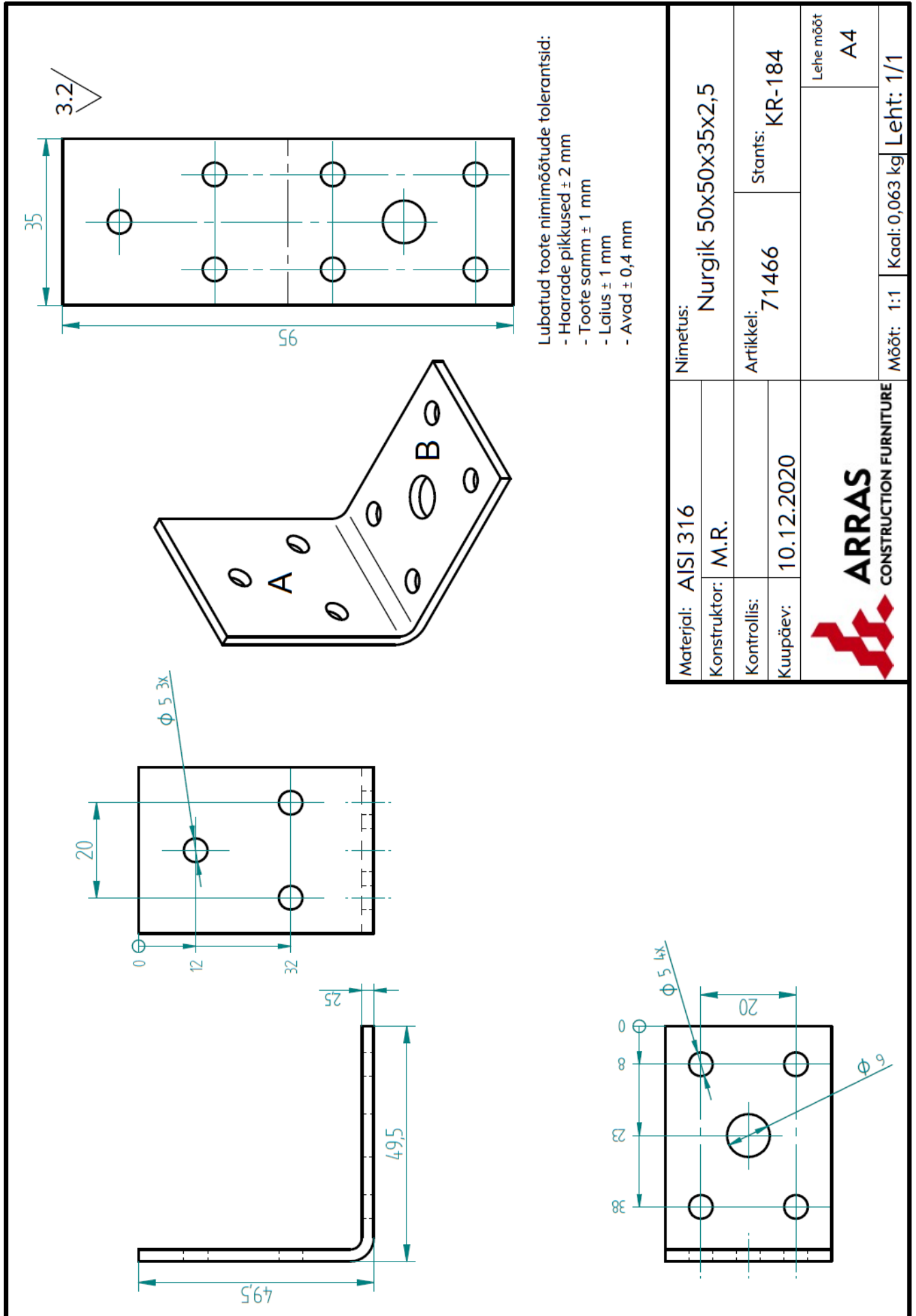

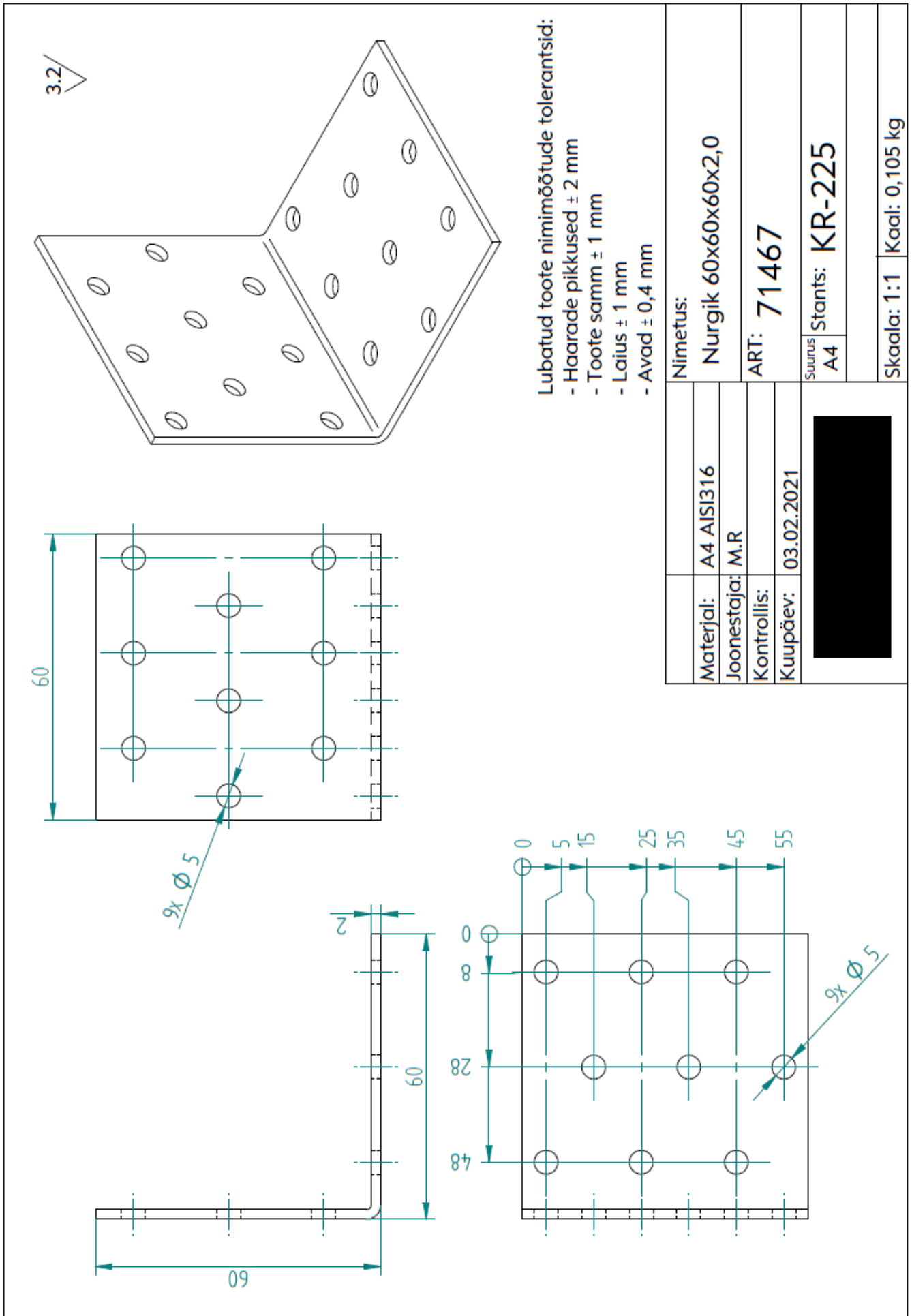

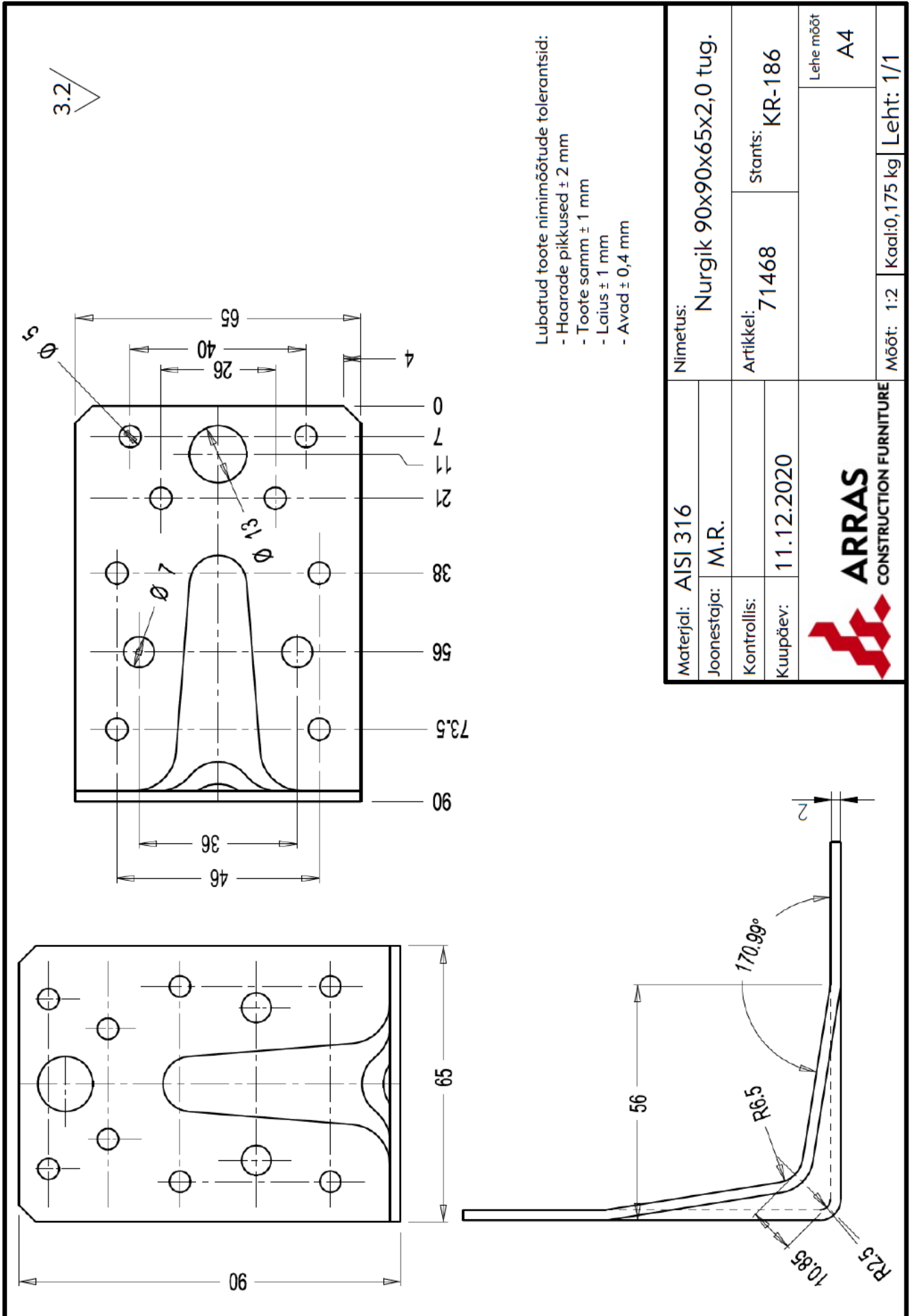

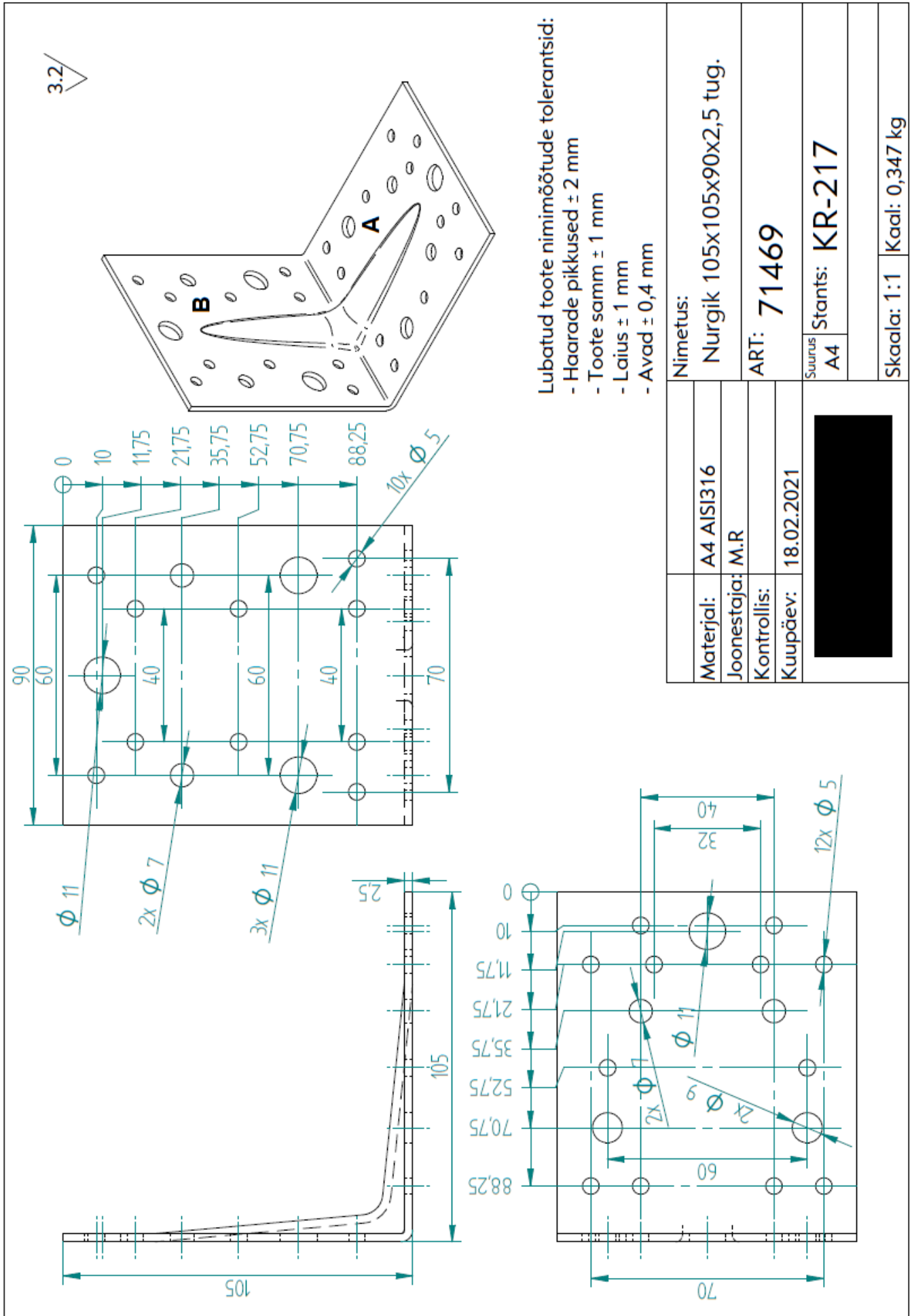

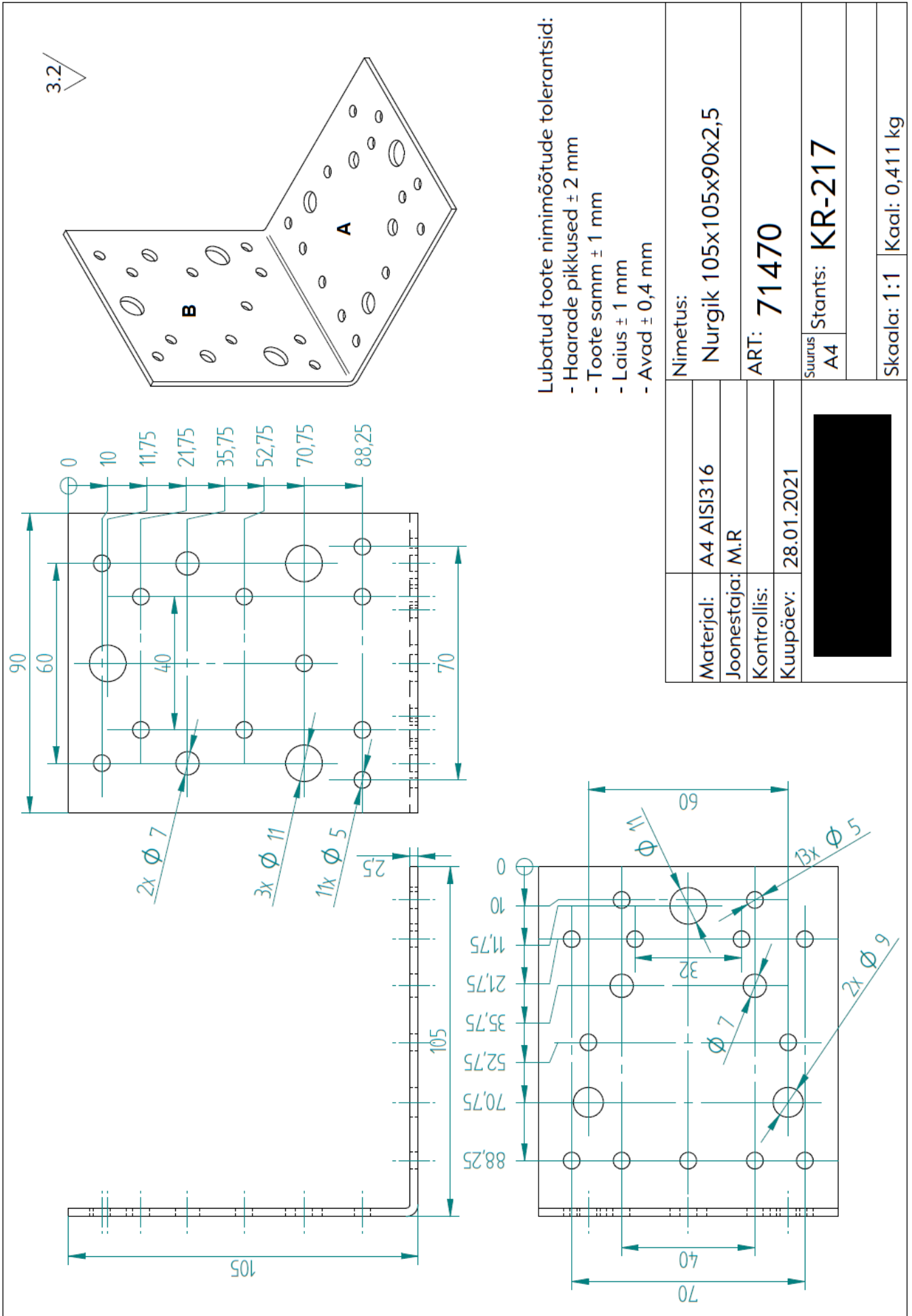



Lubatud toote nimimõõtude tolerantsid:

- Haarade pikkused ± 2 mm
- Toote samm ± 1 mm
- Laius ± 1 mm
- Avad ± 0,4 mm

Materjal:	A4 AISI316	Nimetus:	Nurgik 105x105x90x2,5
Joonestaja:	M.R	ART:	71470
Kontrollis:		Suurus	A4
Kuupäev:	28.01.2021	Starts:	KR-217
		Skaala:	1:1
		Kaali:	0,411 kg

3.2

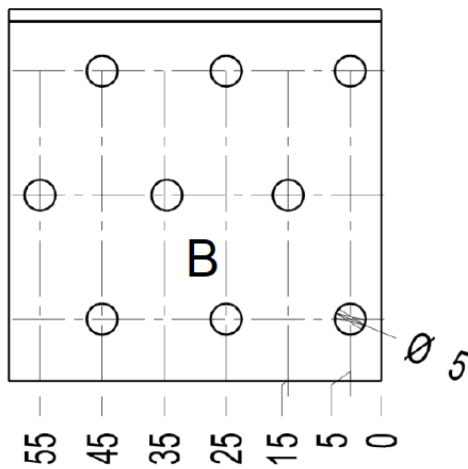
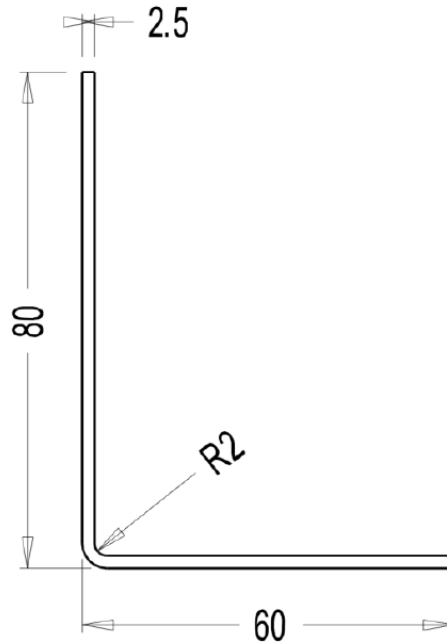
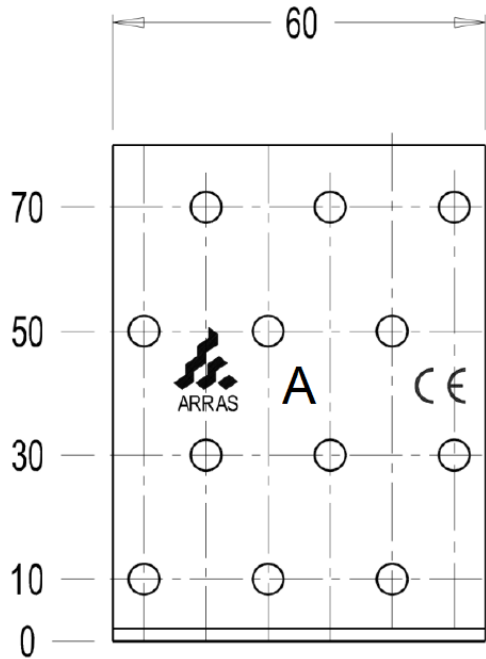

Lubatud toote nimimõõtude tolerantsid:

Haarade pikkused '+/-2 mm

Toote samm '+/-1 mm

Laius '+/-1 mm

Paksus

2,0 mm '+/- 0,15 mm

2,5 mm '+/- 0,17 mm

3,0 mm '+/- 0,20mm

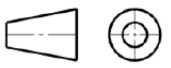
Materjal: HDG DX 510 Z275 MAC				Arv: 1 tk.	Mass:	Mõõt: M1:1	A4
Konstruktor	R.K.		20.05.14	Ninetus: Nurgiku 80x60x60 71502			
Kontrollis				Tähis: KR192		Muudat. -XX	Tootekaart
			Leht: 1 Lehti: 1				

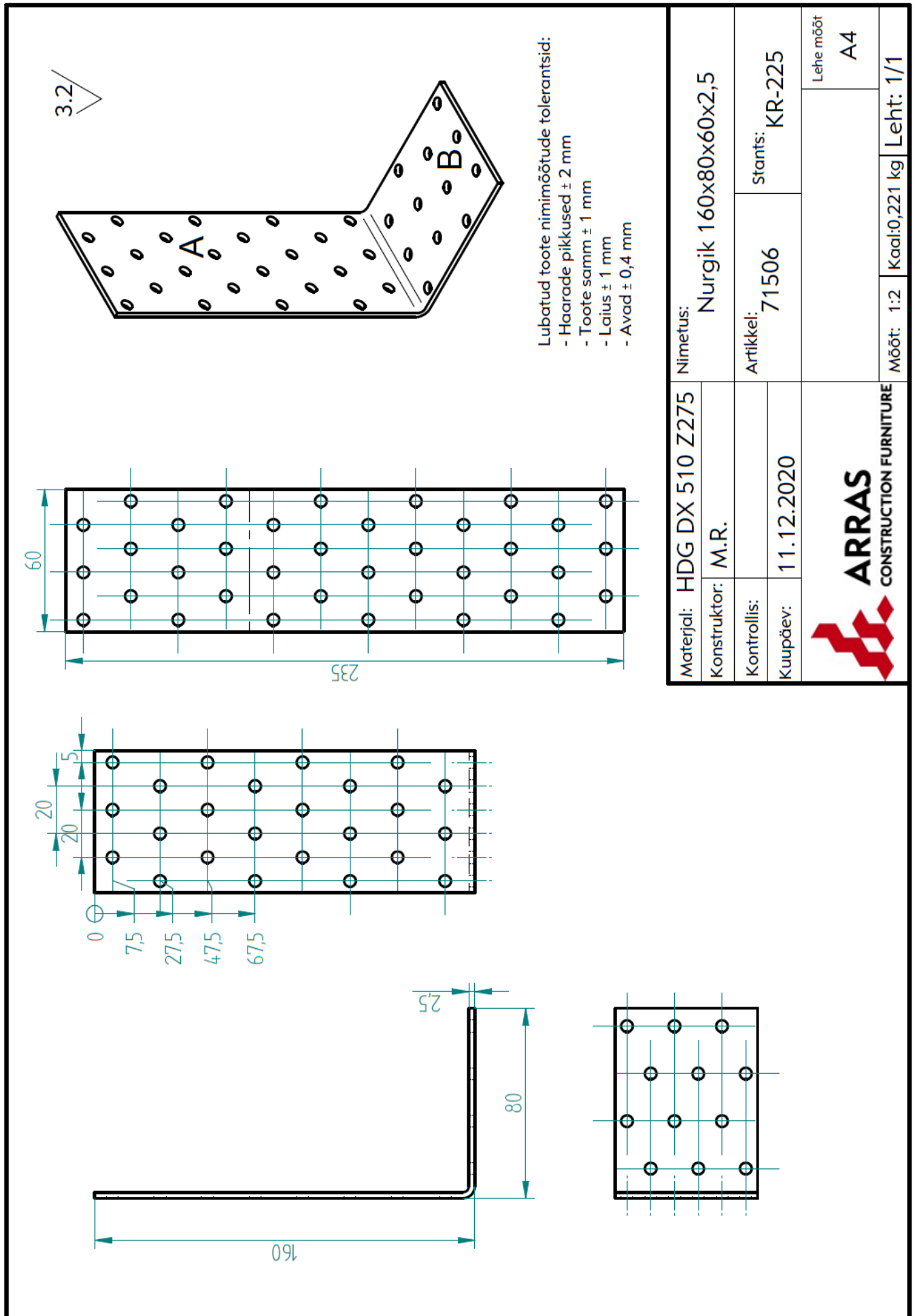

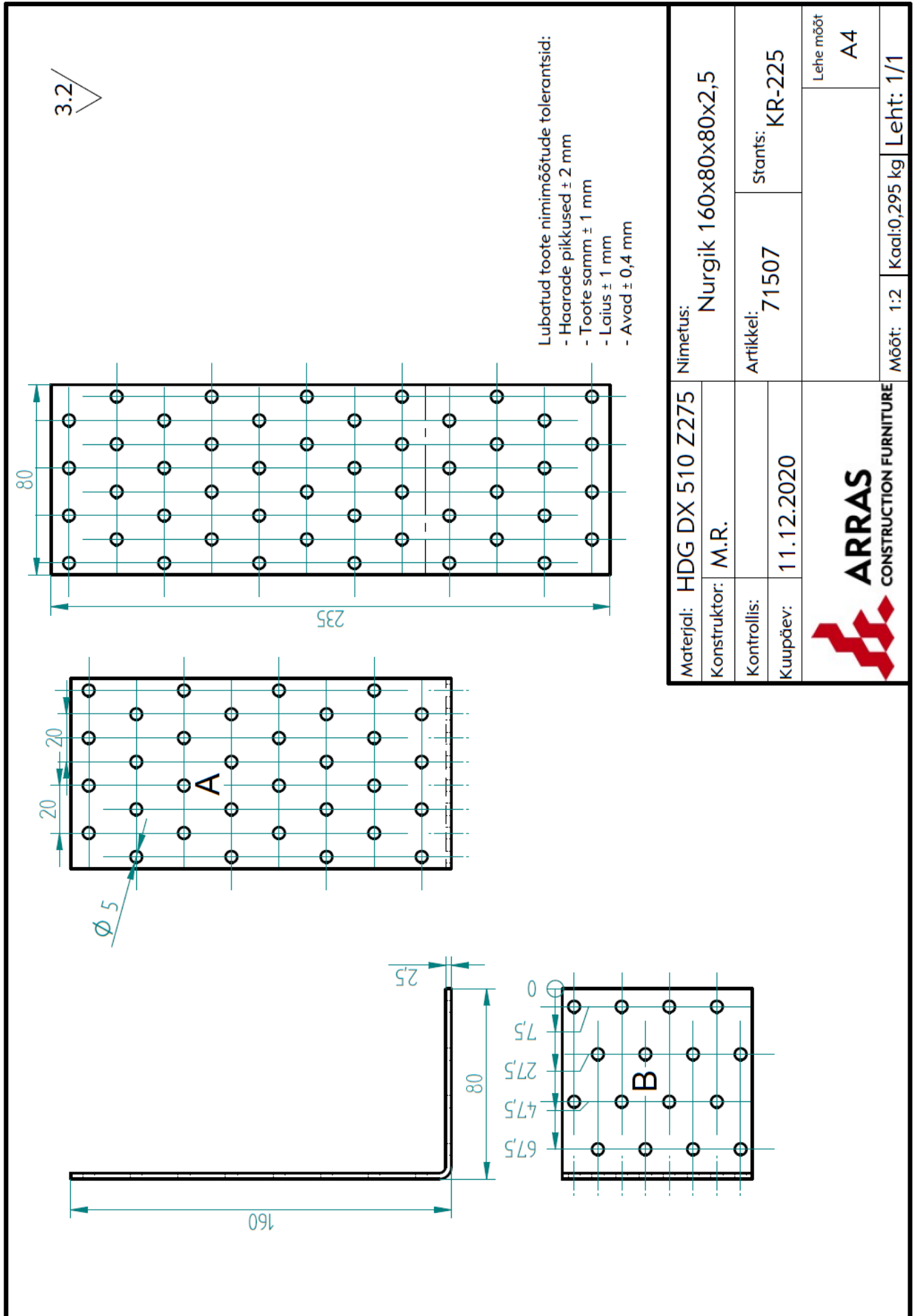

ANNEX 1: Product details and definitions

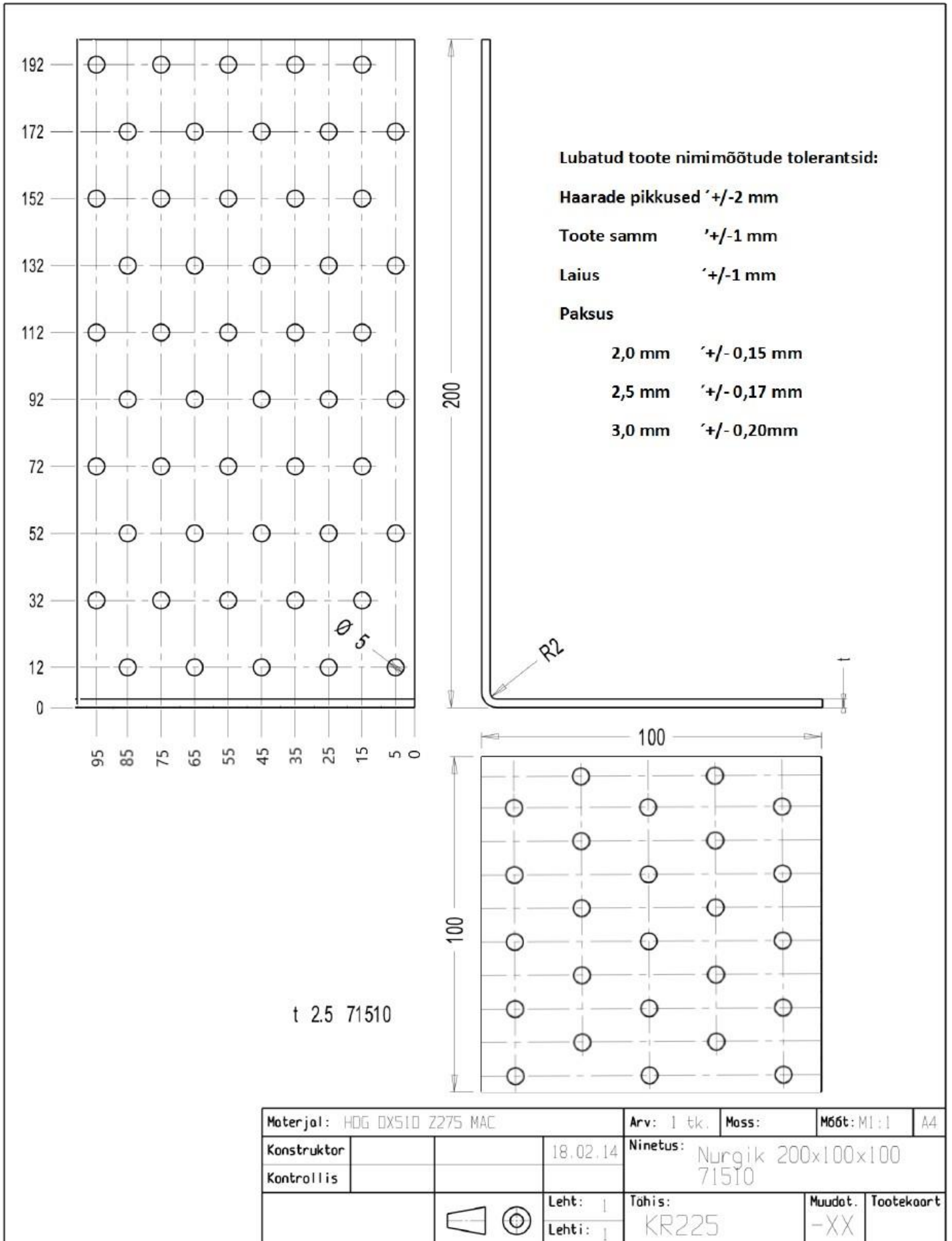

Materjal: HDG DX51D Z275 MAC			Arv: 1 tk.	Moss:	Mõõt: M1:1	A4
Konstruktor		18.02.14	Ninetus: Nurgik 200x100x100 71510			
Kontrollis						
		Leht: 1 Lehti: 1	Tähis: KR225	Muudat. -XX	Tootekaart	

3.2

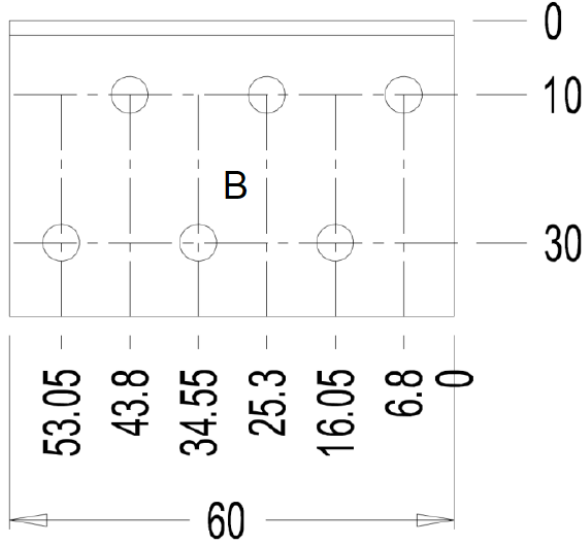
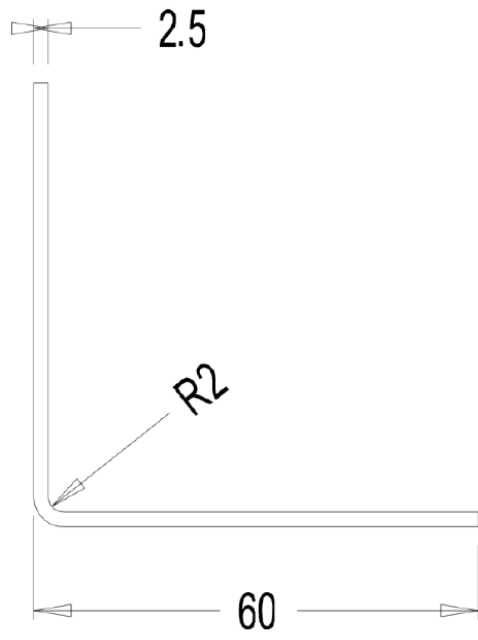
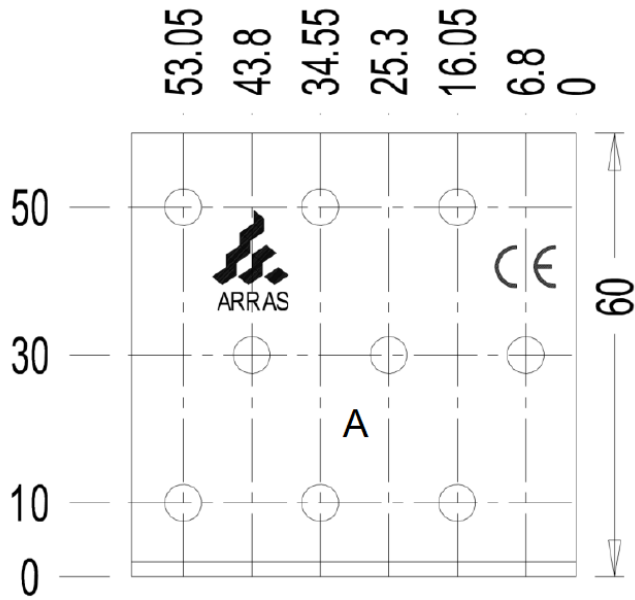

Lubatud toote nimimõõtude tolerantsid:

- Haarade pikkused** +/- 2 mm
- Toote samm** +/- 1 mm
- Laius** +/- 1 mm
- Paksus**
 - 2,0 mm +/- 0,15 mm
 - 2,5 mm +/- 0,17 mm
 - 3,0 mm +/- 0,20mm

Materjal: HDG DX 510 Z275 MAC			Arv: X tk.	Mass:	Mõõt: M1:1	A4
Konstruktor	R.K.	15.03.16	Ninetus: Nurgik 60x40x60 71512			
Kontrollis						
			Leht: 1	Tähis: KR 192		Muudat. Tootekaart
			Lehti: 1			-XX

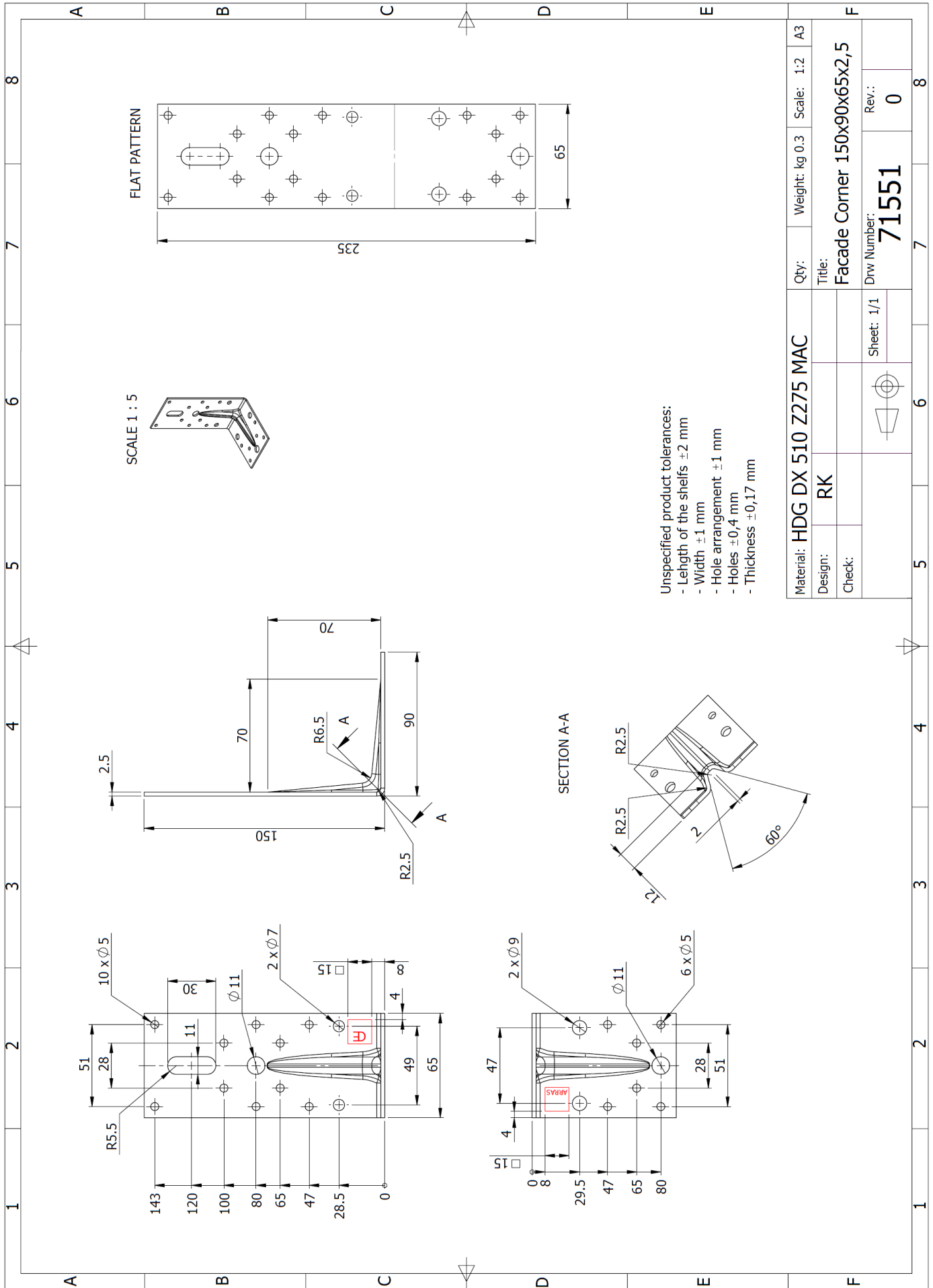

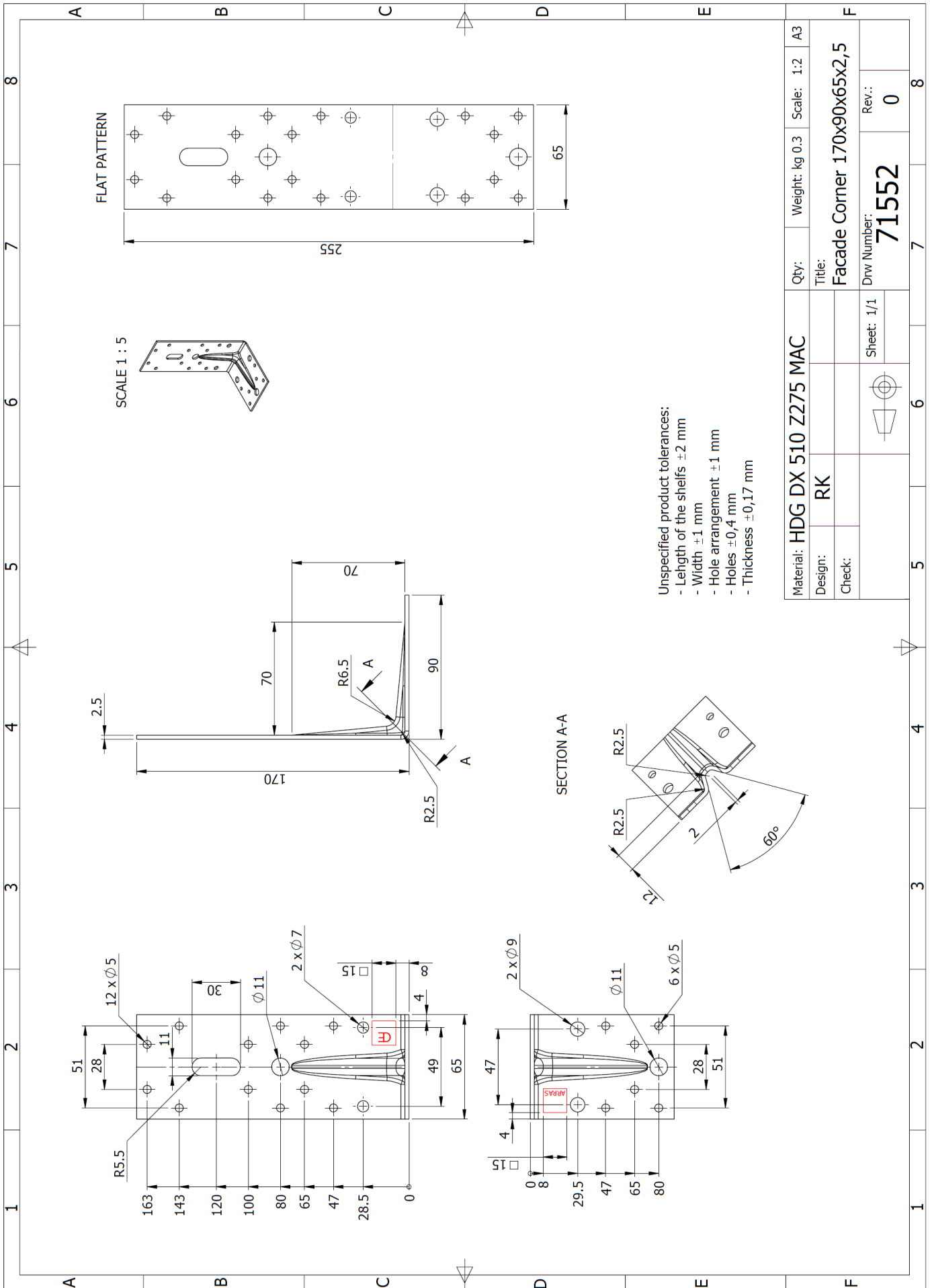

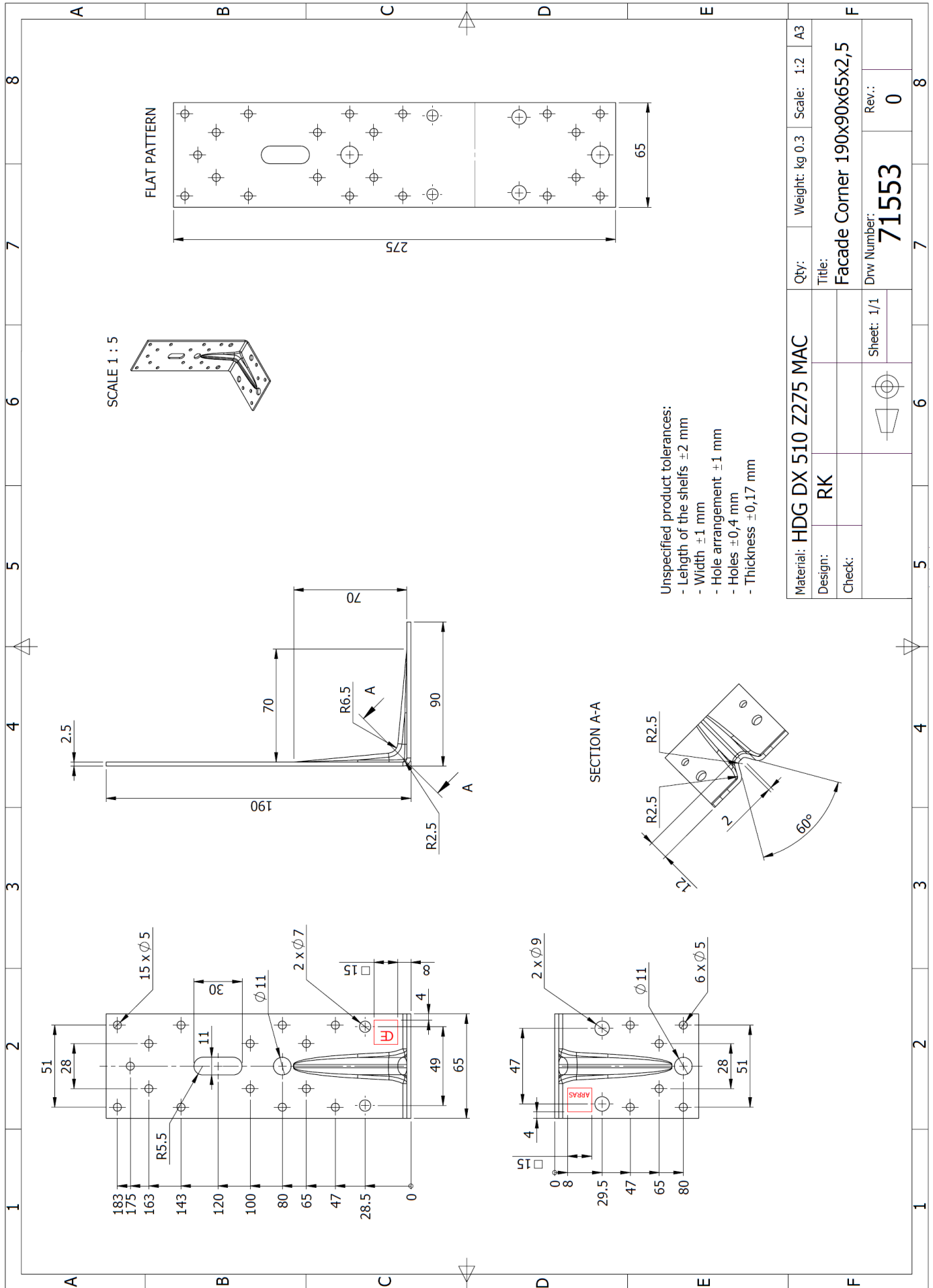

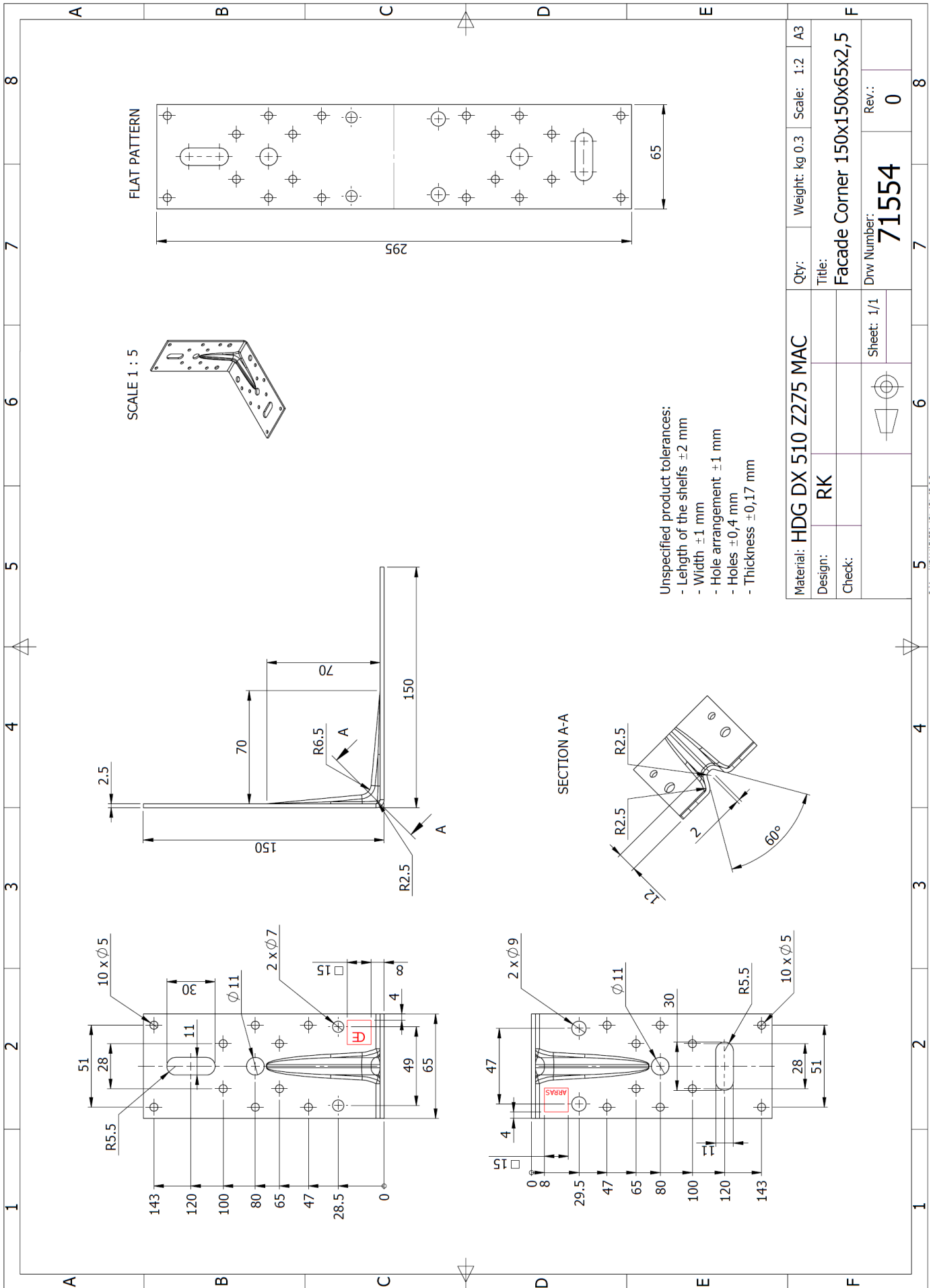

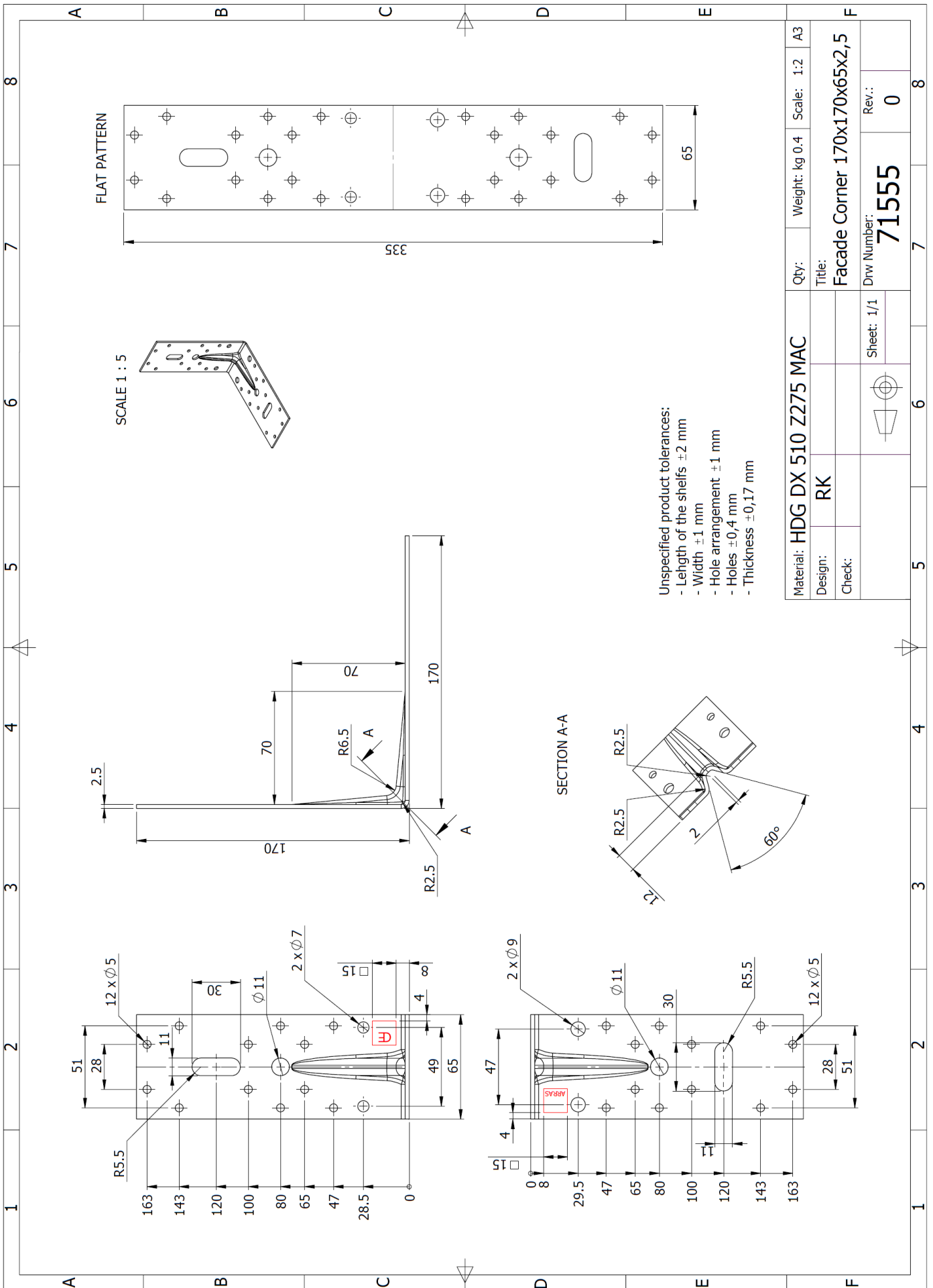

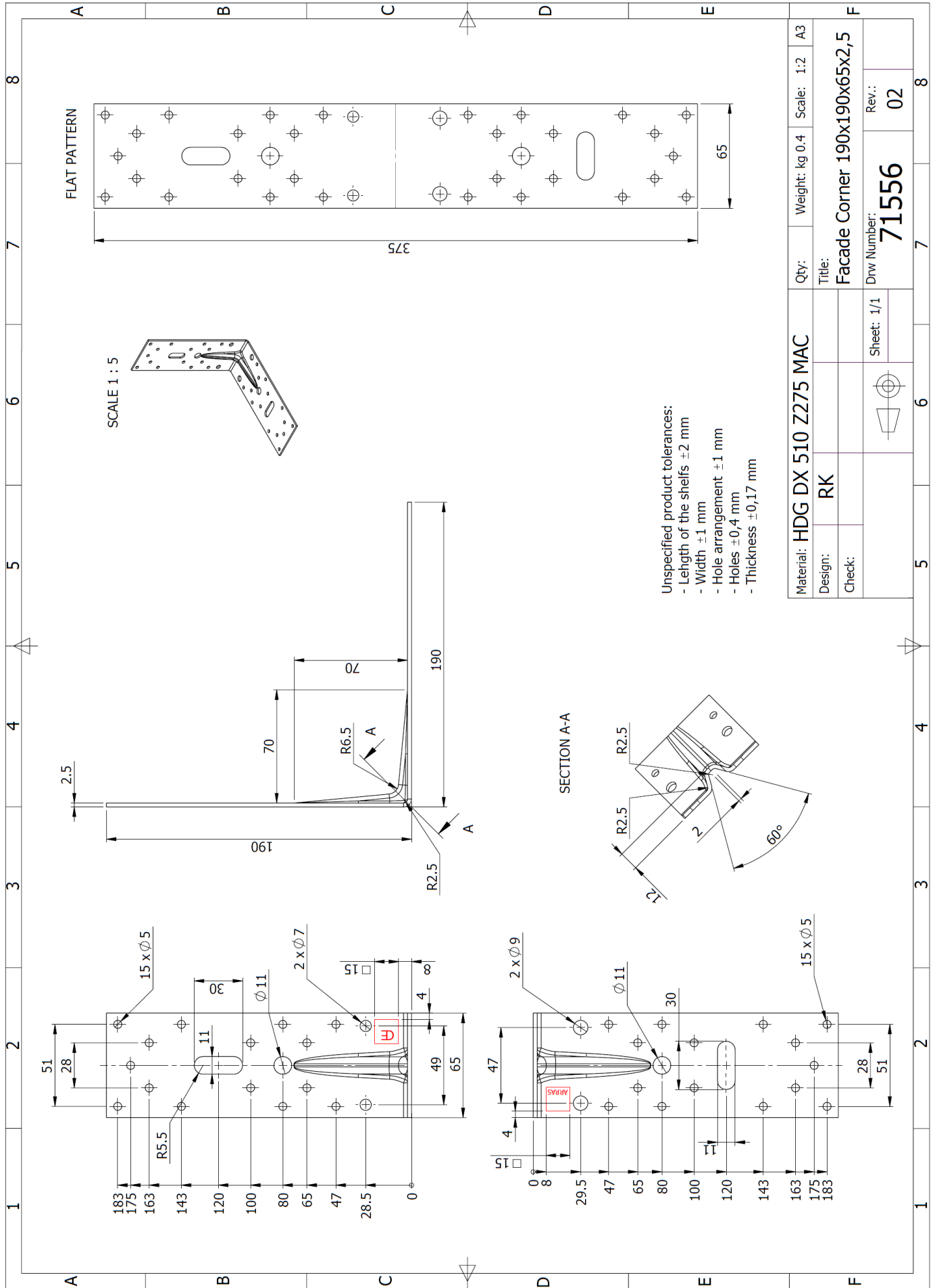

3.2

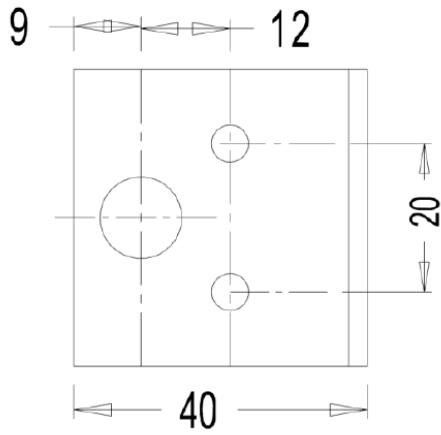

Lubatud toote nimimõõtude tolerantsid:

Haarade pikkused ± 2 mm

Toote samm ± 1 mm

Laius ± 1 mm

Paksus

2,0 mm $\pm 0,15$ mm

2,5 mm $\pm 0,17$ mm

3,0 mm $\pm 0,20$ mm



t 2.5 73001

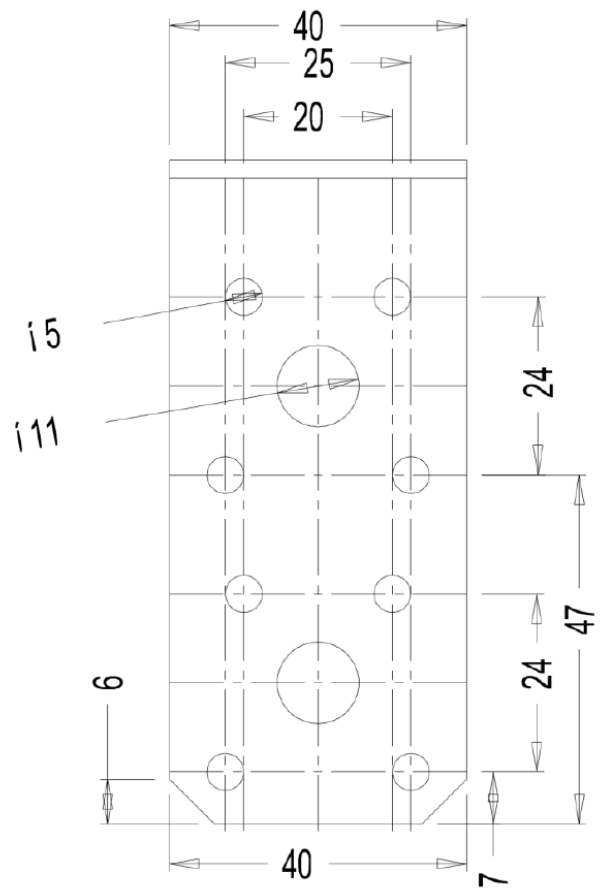

Materjal: HDG DX51D Z275 MAC				Arv: 1 tk.	Mass:	Mõõt: M1:1	A4
Konstruktor	R.K.	1.04.14	Ninetus: Nurgik 90x40x40 73001				
Kontrollis							
			Leht: 1	Tõhis: KR198		Muudat. -XX	Tootekaart
			Lehti: 1				

ANNEX 1: Product details and definitions

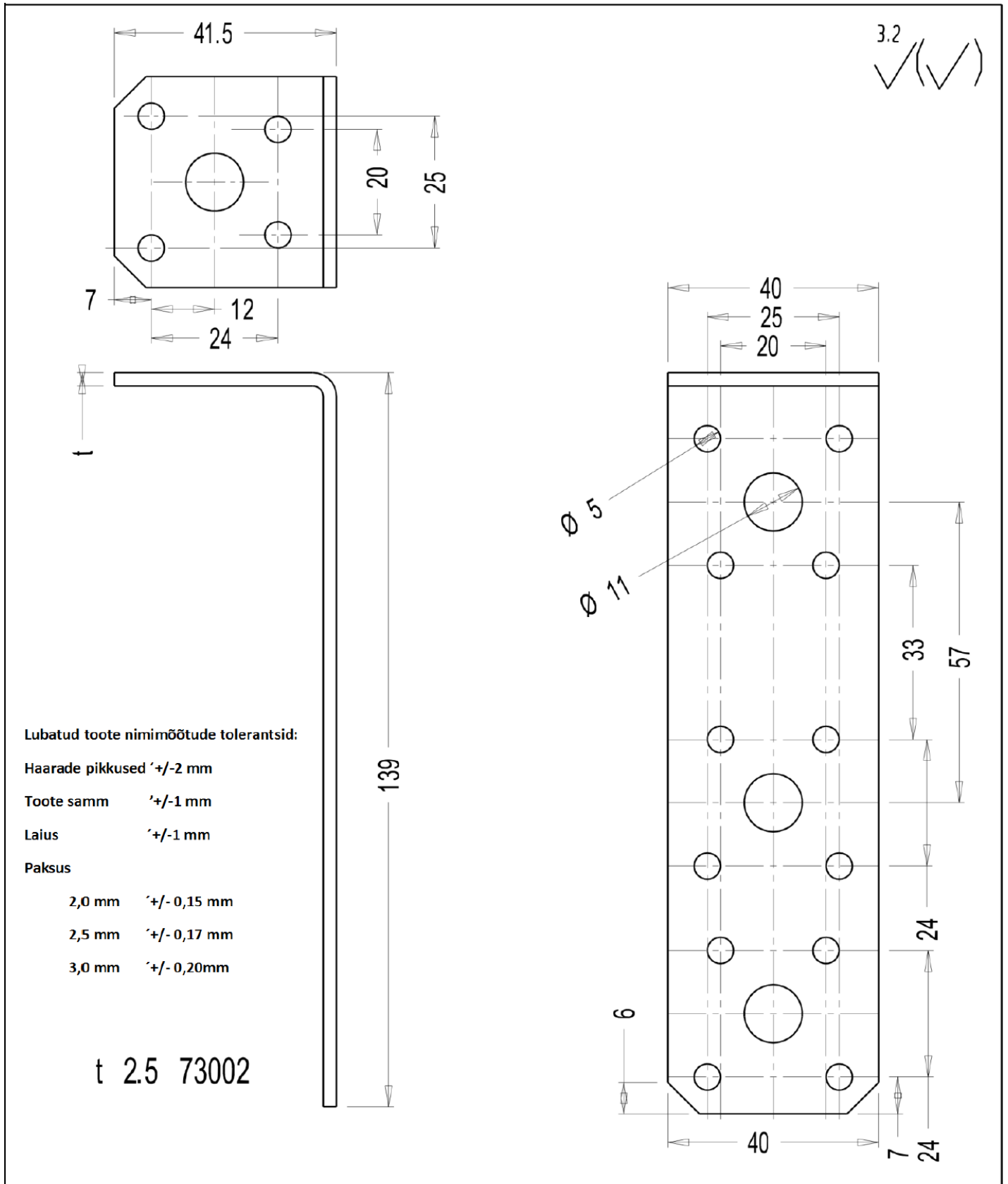

Materjal: HDG DX51D Z275 MAC				Arv: 1 tk.	Mass:	Mõõt: M1:1	A4
Konstruktor	R.K.		28.07.10	Ninetus: Nurgik 140x40x40 73002			
Kontrollis							
			Leht: 1 Lehti: 1	Tähis: KR198	Muudat. -XX	Tootekaart	

3.2

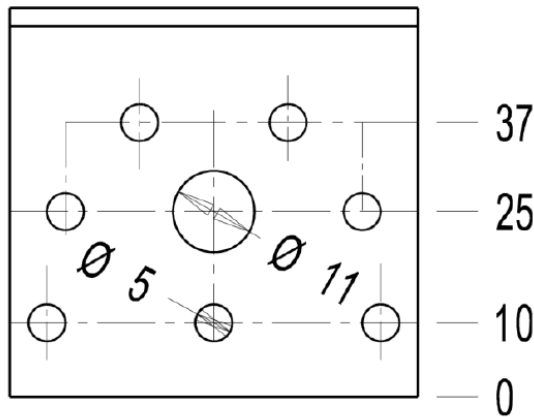
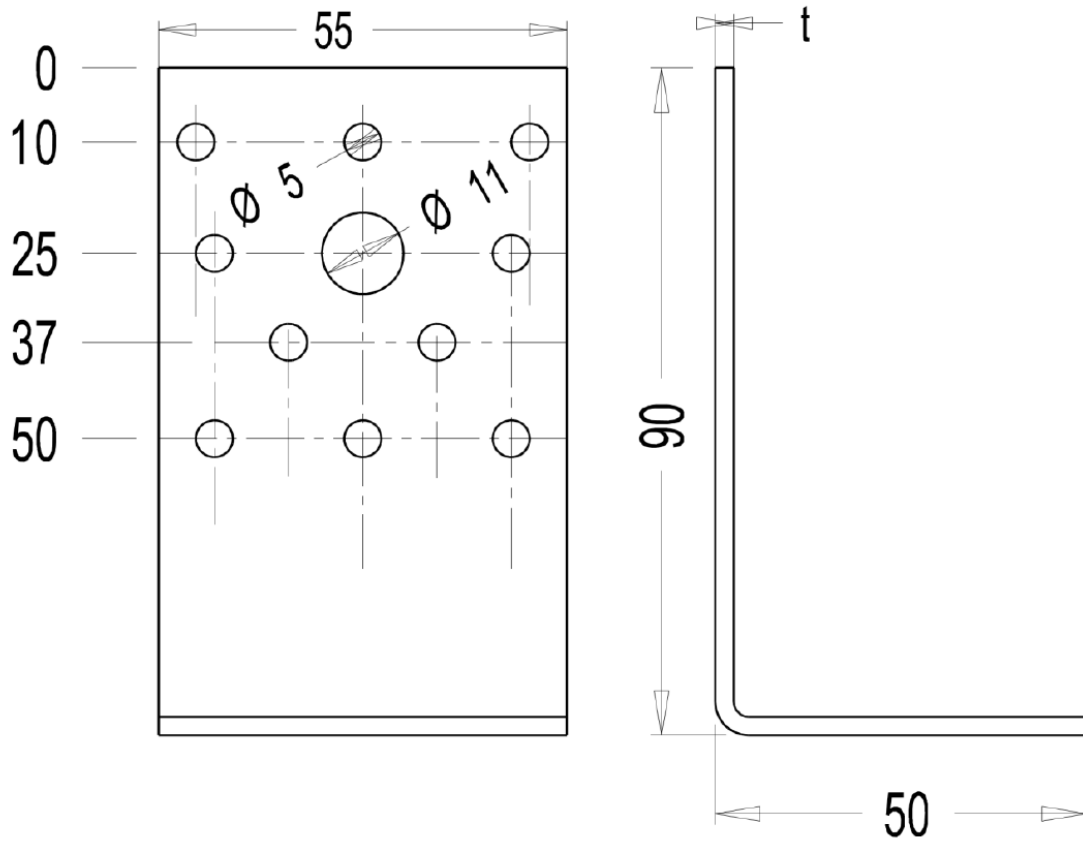

Lubatud toote nimimõõtude tolerantsid:

Haarade pikkused ± 2 mm

Toote samm ± 1 mm

Laius ± 1 mm

Paksus

2,0 mm $\pm 0,15$ mm

2,5 mm $\pm 0,17$ mm

3,0 mm $\pm 0,20$ mm

73006 t 2,5

Materjal: HDG DX 510 Z275 MAC				Arv: X tk.	Mass:	Mõõt: M1:1	A4
Konstruktor	R.K.		28.08.10	Ninetus: Nura ik 90x50x55 73006			
Kontrollis							
			Leht: 1 Lehti: 1	Tähis: KR 188	Muudat. -XX	Tootekaart	

3.2 

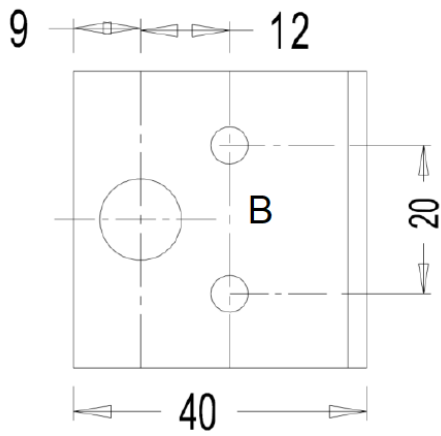

Lubatud toote nimimõõtude tolerantsid:

Haarade pikkused ± 2 mm

Toote samm ± 1 mm

Laius ± 1 mm



Paksus

2,0 mm $\pm 0,15$ mm

2,5 mm $\pm 0,17$ mm

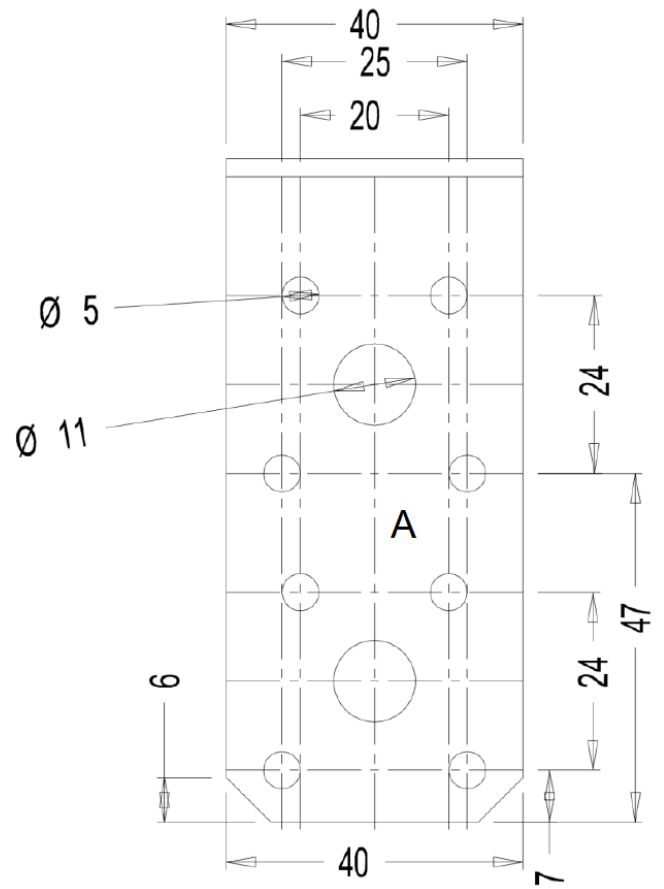
3,0 mm $\pm 0,20$ mm



Materjal: HDG DX51D Z275 MAC				Arv: 1 tk.	Mass:	M66t: M1:1	A4
Konstruktor	R.K.	15.03.16	Ninetus: Nurgik 90x40x40x3.0 73007				
Kontrollis							
			Leht: 1	Tähis: KR198		Muudot. -XX	Tootekaart
			Lehti: 1				

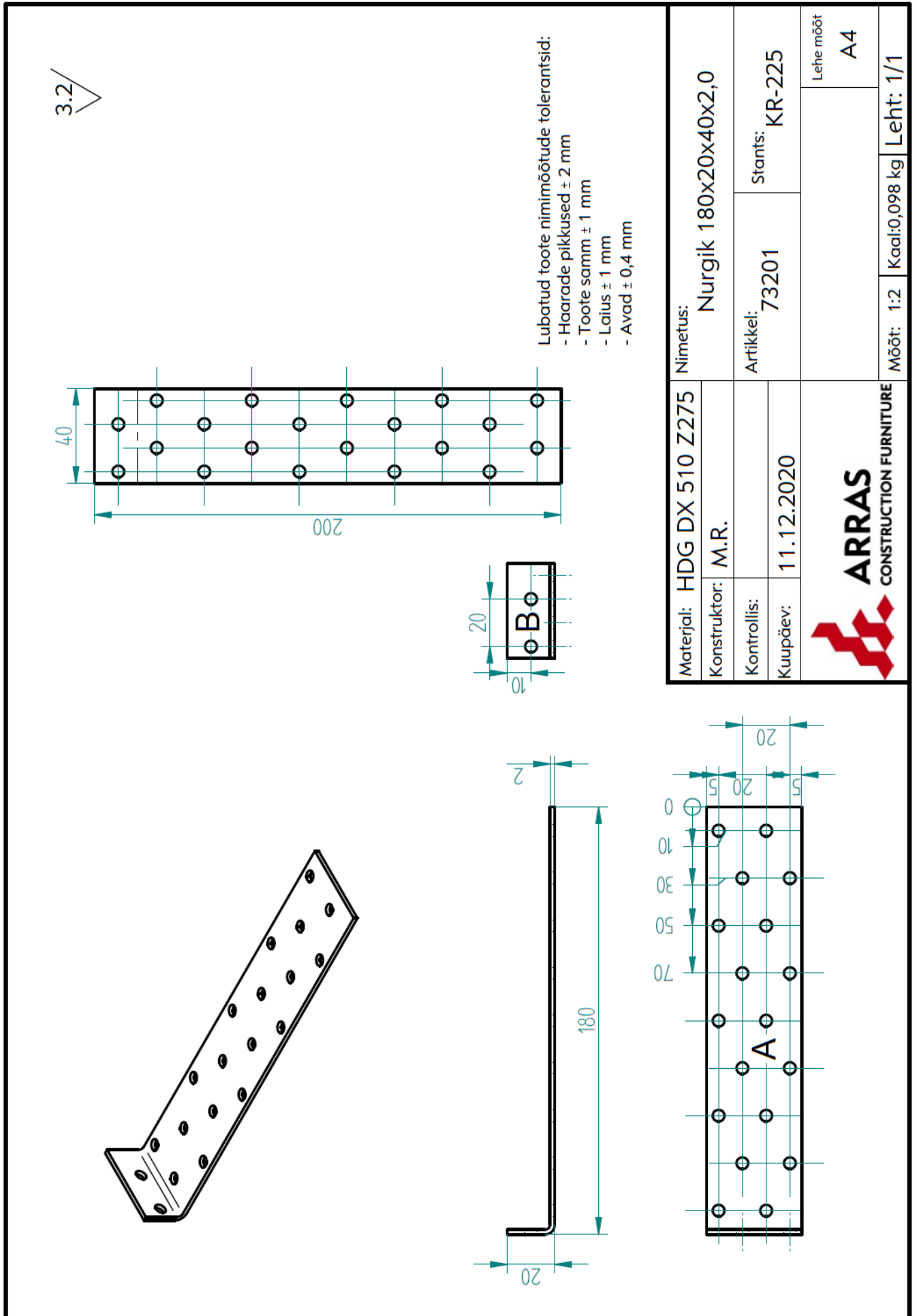

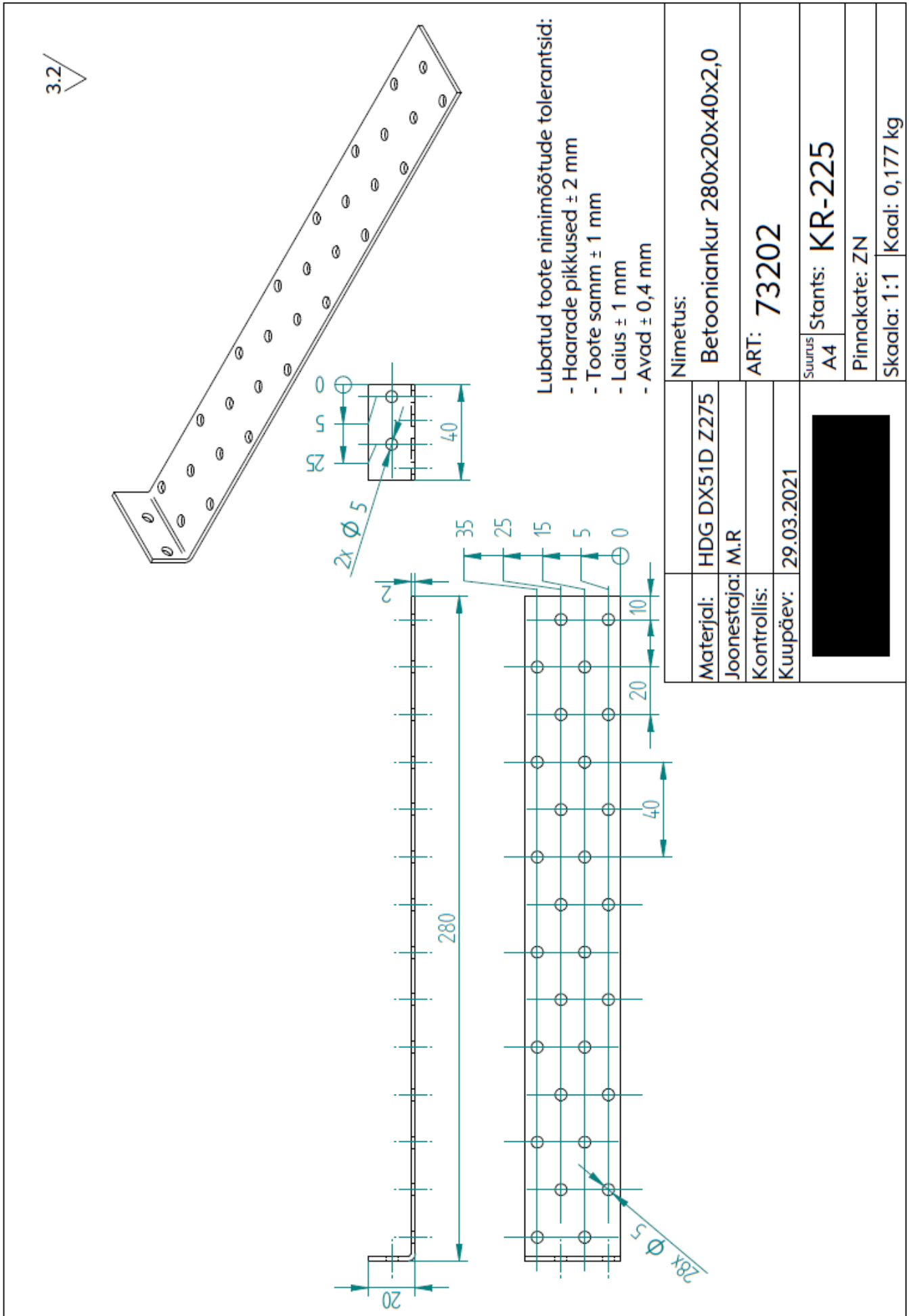

3.2

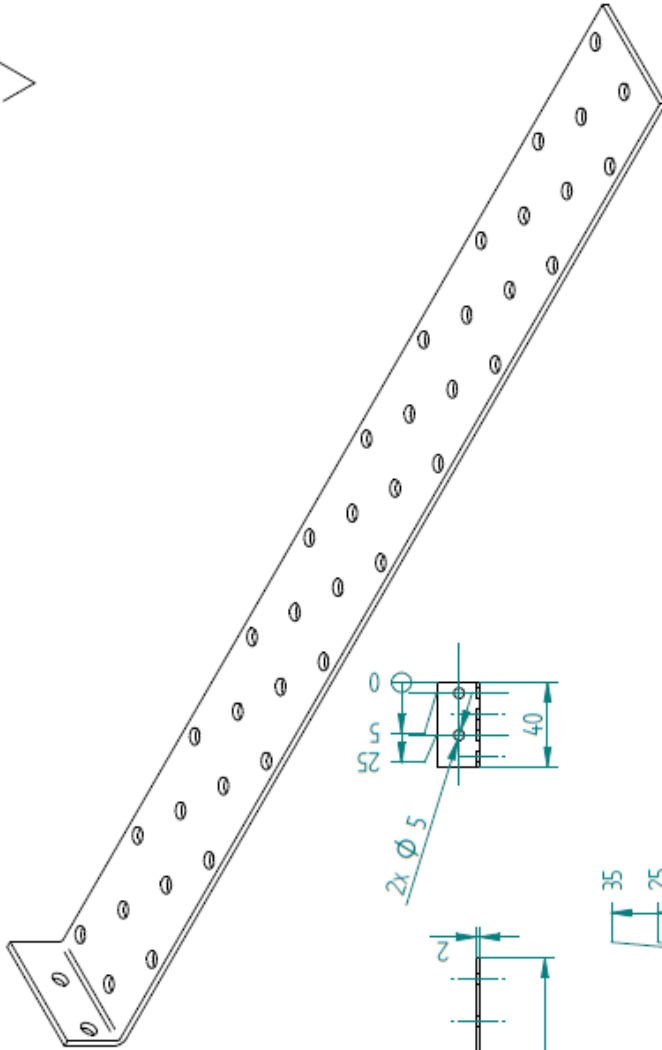

Lubatud toote nimimõõtude tolerantsid:

- Haarade pikkused ± 2 mm
- Toote samm ± 1 mm
- Laius ± 1 mm
- Avad $\pm 0,4$ mm

Materjal:	HDG DX51D Z275	Nimetus:	Betooniankur 380x20x40x2,0
Joonestaja:	M.R	ART:	73203
Kontrollis:		Suurus	A4
Kuupäev:	29.03.2021	Stants:	KR-225
		Pinnakate:	ZN
		Skaala:	1:1
		Kaal:	0,237 kg

3.2

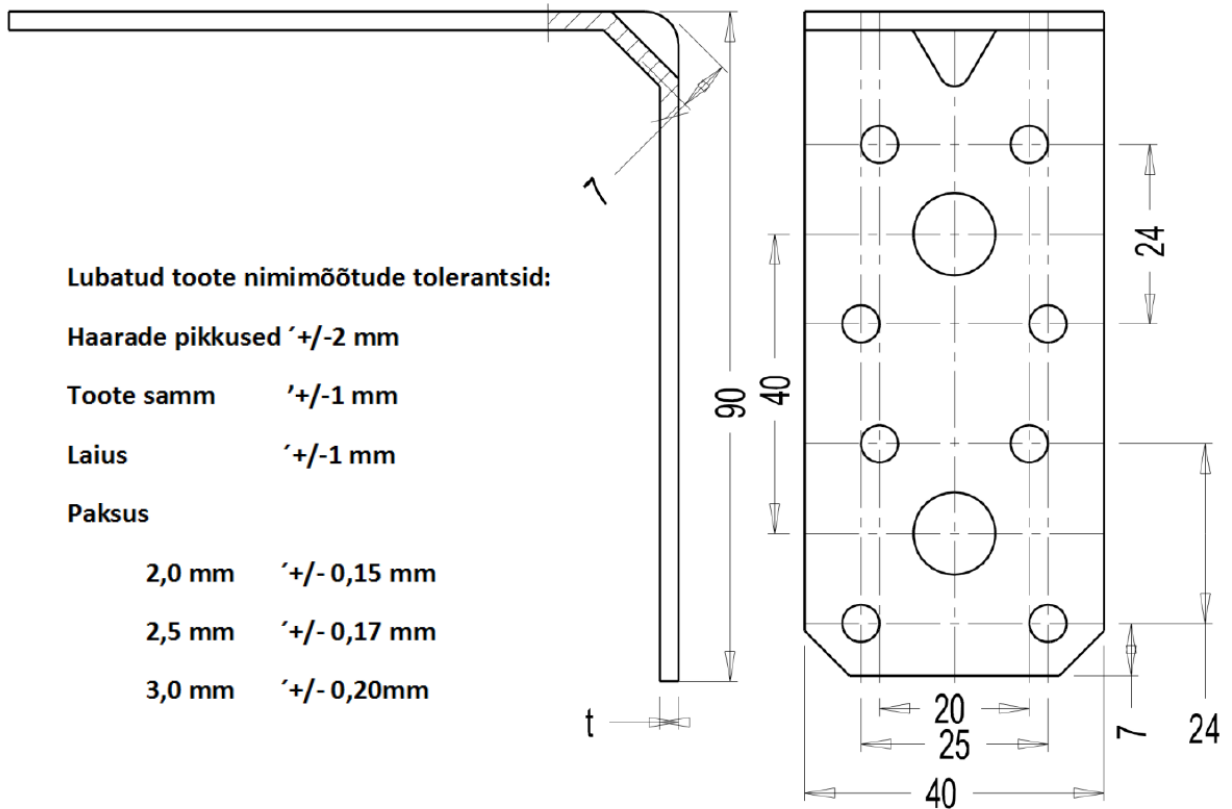
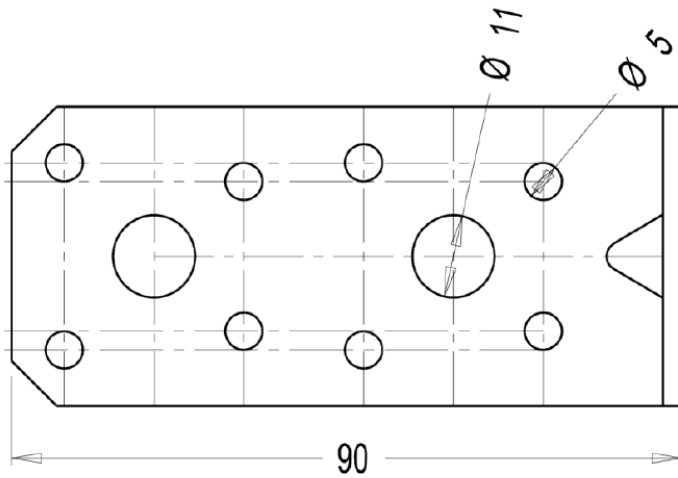

Lubatud toote nimimõõtude tolerantsid:

Haarade pikkused ± 2 mm

Toote samm ± 1 mm

Laius ± 1 mm

Paksus

2,0 mm $\pm 0,15$ mm

2,5 mm $\pm 0,17$ mm

3,0 mm $\pm 0,20$ mm

t 2.5 73605

Materjal: HDG DX51D Z275 MAC				Arv: 1 tk.	Mass:	Mõõt: M1:1	A4
Konstruktor	R.K.	28.07.10	Ninetus: Nurgik 90x90x40 73605				
Kontrollis							
			Leht: 1	Tähis: KR198	Muudat. -XX	Tootekaart	
			Lehti: 1				

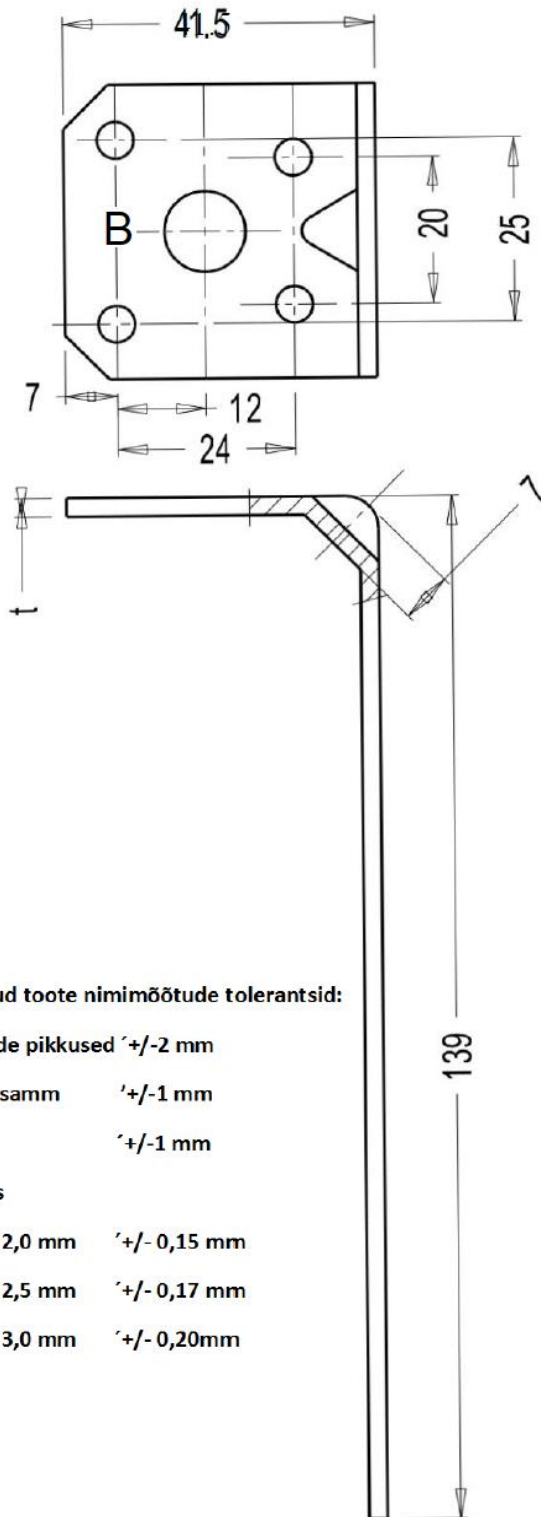

3.2

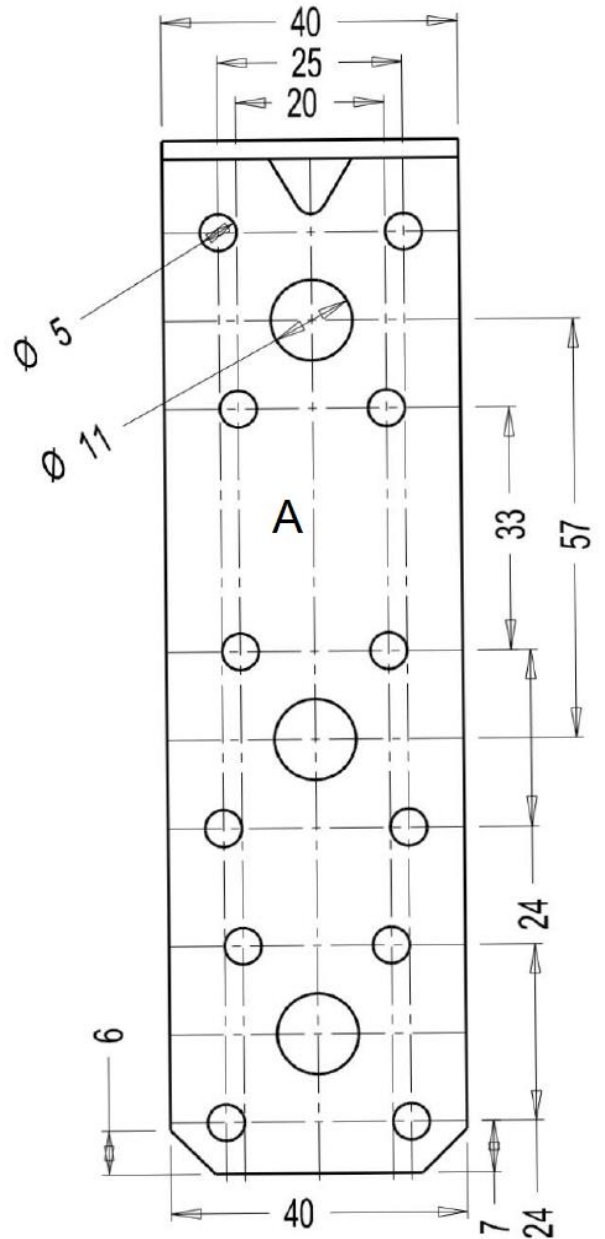

Lubatud toote nimimõõtude tolerantsid:

Haarade pikkused ± 2 mm

Toote samm ± 1 mm

Laius ± 1 mm

Paksus

2,0 mm $\pm 0,15$ mm

2,5 mm $\pm 0,17$ mm

3,0 mm $\pm 0,20$ mm

t 2.5 73606

Materjal: HDG DX51D Z275 MAC			Arv: 1 tk.	Moss:	Mõõt: M1:1	A4
Konstruktor	R.K.	28.07.10	Ninetus: Nurgik 140x40x40 73606			
Kontrollis						
		Leht: 1	Tähis: KR198	Muudat. -XX	Tootekoort	
		Lehti: 1				

3.2

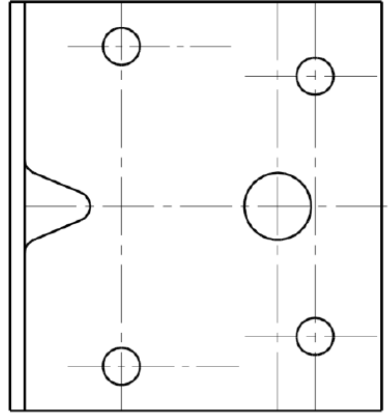
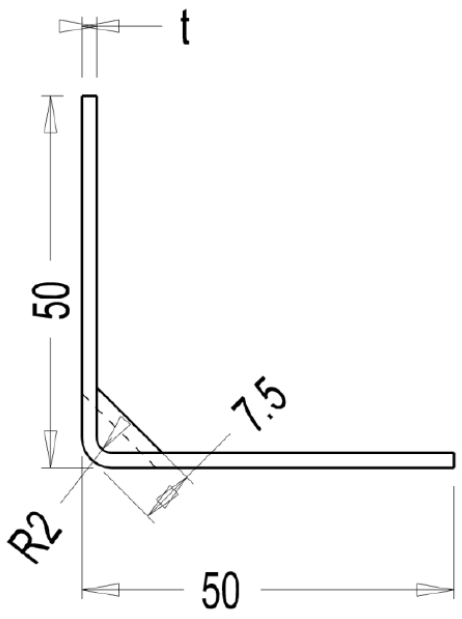
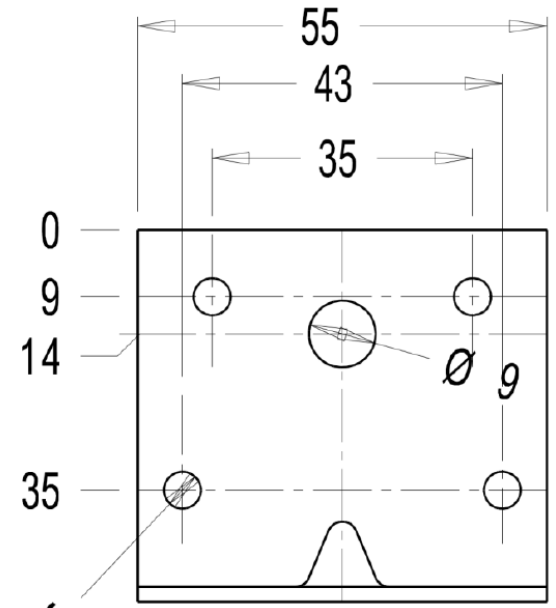

Lubatud toote nimimõõtude tolerantsid:
 Haarade pikkused ± 2 mm
 Toote samm ± 1 mm
 Laius ± 1 mm
 Paksus
 2,0 mm $\pm 0,15$ mm
 2,5 mm $\pm 0,17$ mm
 3,0 mm $\pm 0,20$ mm
t 2,5 73609

Materjal: HDG DX51D Z275 MAC				Arv: 1 tk.	Mass:	Mõõt: M1:1	A4
Konstruktor	R.K.		14.05.09	Ninetus: Nurgik 50x50x55 73609			
Kontrollis							
			Leht: 1 Lehti: 1	Tähis: KR 212	Muudat. -XX	Tootekaart	

3.2

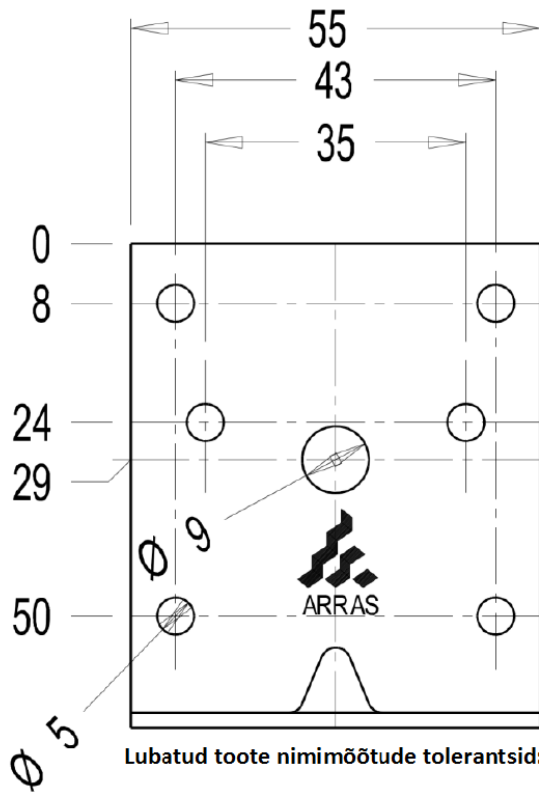

Lubatud toote nimimõõtude tolerantsid:

Haarade pikkused '+/-2 mm

Toote samm '+/-1 mm

Laius '+/-1 mm

Paksus

2,0 mm '+/- 0,15 mm

2,5 mm '+/- 0,17 mm

3,0 mm '+/- 0,20mm

t 2.0 73610

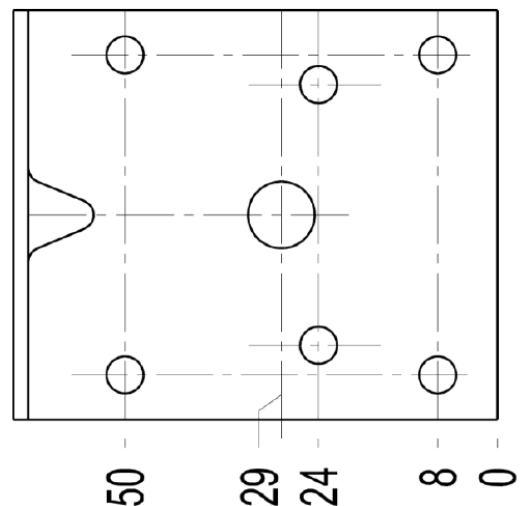
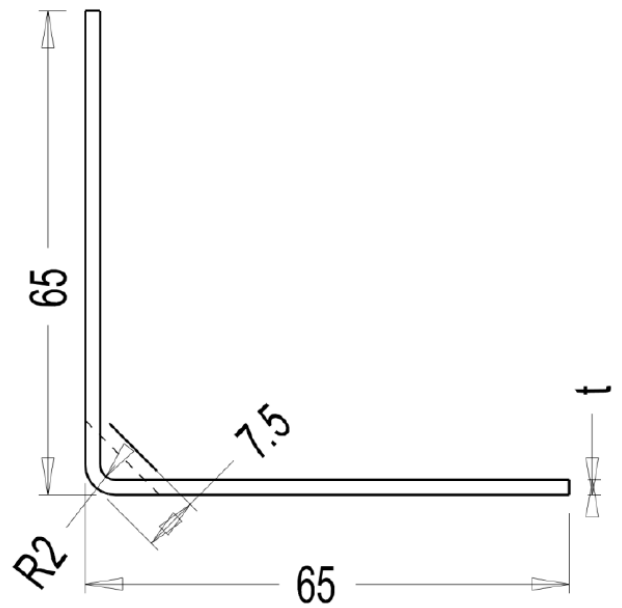

Materjal: HDG DX51D Z275 MAC				Arv: 1 tk.	Mass:	Mõõt: M1:1	A4
Konstruktor	R.K.		14.05.09	Ninetus: Nurgik 65x65x55			
Kontrollis				73610			
			Leht: 1	Tähis: KR 212	Muudat. -XX	Tootekaart	
			Lehti: 1				

3.2

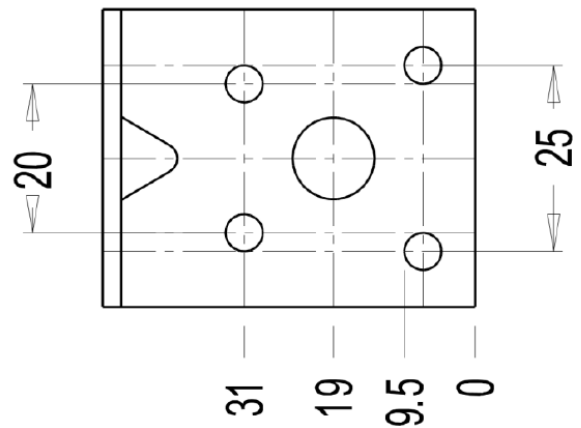
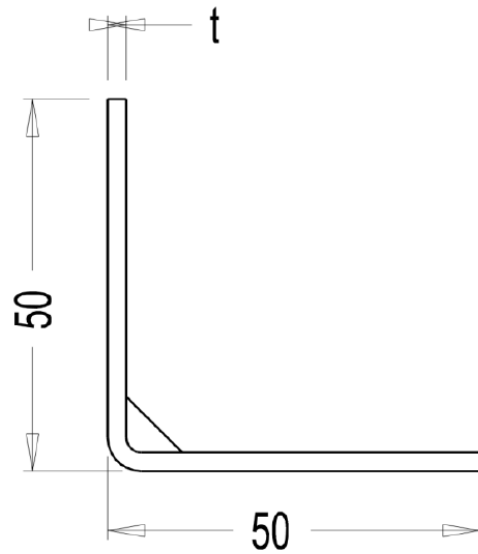
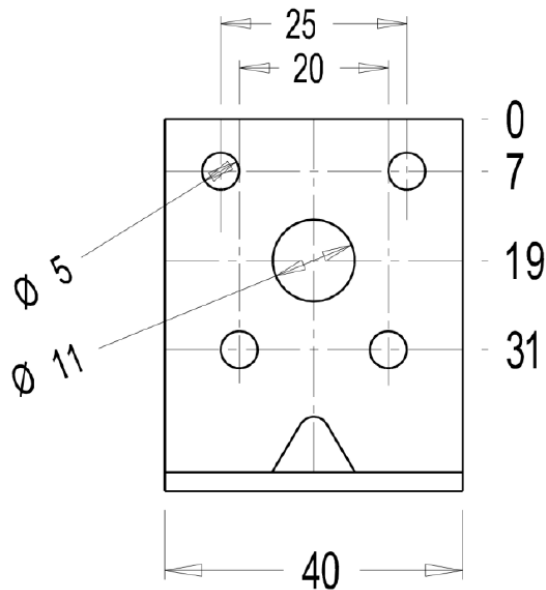

Lubatud toote nimimõõtude tolerantsid:

Haarade pikkused ± 2 mm

Toote samm ± 1 mm

Laius ± 1 mm

Paksus

2,0 mm $\pm 0,15$ mm

2,5 mm $\pm 0,17$ mm

3,0 mm $\pm 0,20$ mm

t 2.0 73612

Materjal: HDG DX51D Z275 MAC				Arv: 1 tk.	Mass:	Mõõt: M1:1	A4
Konstruktor	R.K.		6.04.11	Ninetus: Nurgik 50x50x40 73612			
Kontrollis							
			Leht: 1 Lehti: 1	Tähis: KR198	Muudat. -XX	Tootekaart	

3.2

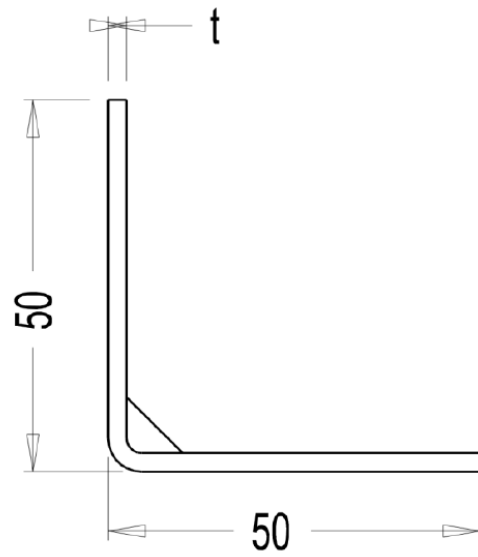
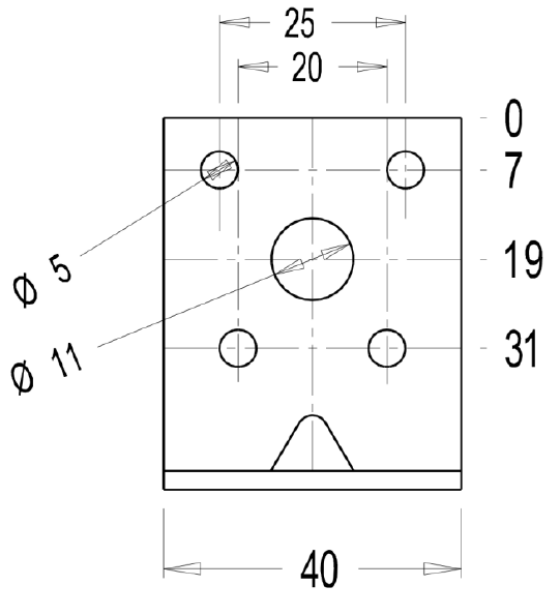
Lubatud toote nimimõõtude tolerantsid:

Haarade pikkused ± 2 mm

Toote samm ± 1 mm

Laius ± 1 mm

Paksus

2,0 mm $\pm 0,15$ mm

2,5 mm $\pm 0,17$ mm

3,0 mm $\pm 0,20$ mm

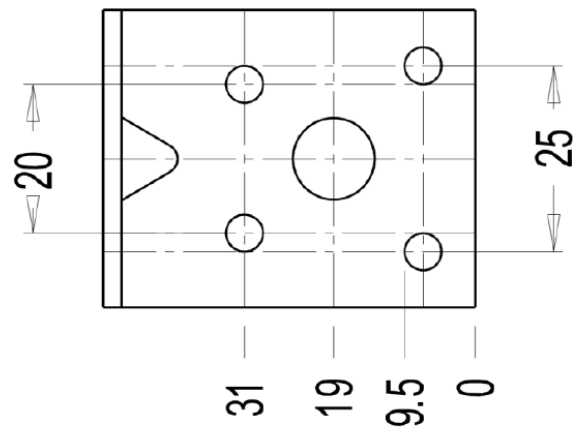

t 2.5 73622

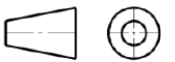
Materjal: HDG DX51D Z275 MAC				Arv: 1 tk.	Mass:	Mõõt: M1:1	A4
Konstruktor	R.K.		6.04.11	Ninetus: Nurqik 50x50x40 73622			
Kontrollis							
				Leht: 1	Tähis: KR198		Muudat. Tootekaart
				Lehti: 1	-XX		

3.2

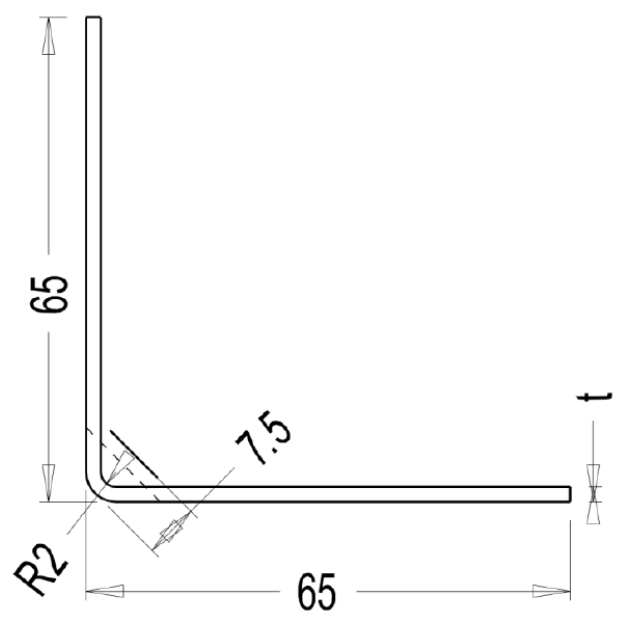
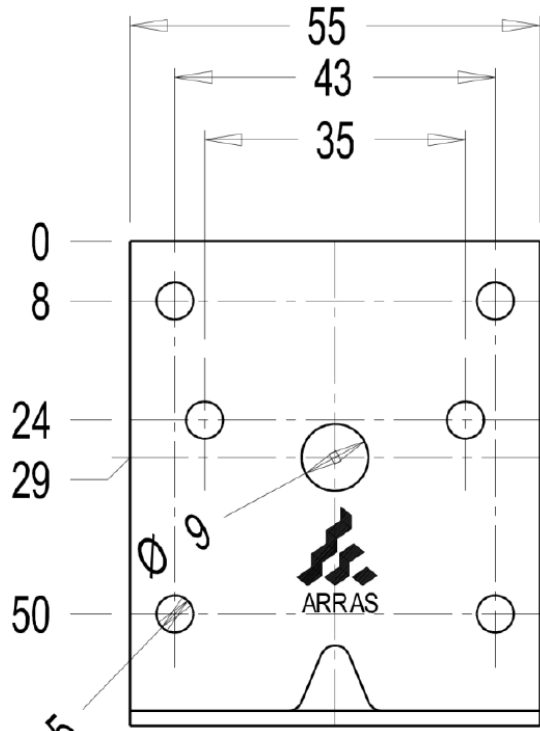

- Lubatud toote nimimõõtude tolerantsid:
- Haarade pikkused ± 2 mm
 - Toote samm ± 1 mm
 - Laius ± 1 mm
 - Paksus
 - 2,0 mm $\pm 0,15$ mm
 - 2,5 mm $\pm 0,17$ mm
 - 3,0 mm $\pm 0,20$ mm

t 3.0 73623

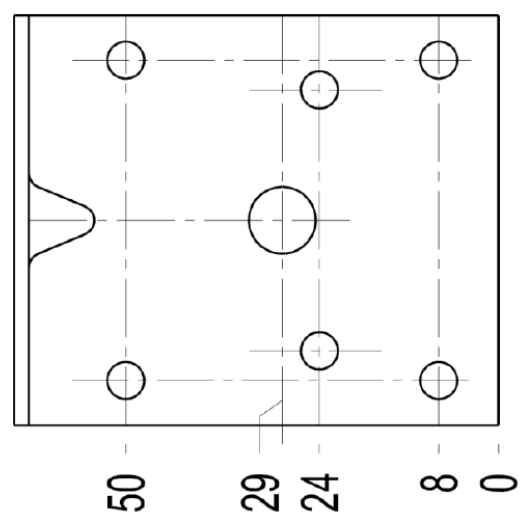

Materjal: HDG DX51D Z275 MAC				Arv: 1 tk.	Mass:	Mõõt: M1:1	A4
Konstruktor	R.K.	14.05.09	Ninetus: Nurgik 65x65x55				
Kontrollis			73623				
		Leht: 1	Tähis: KR 212		Muudat. -XX	Tootekaart	
		Lehti: 1					

3.2

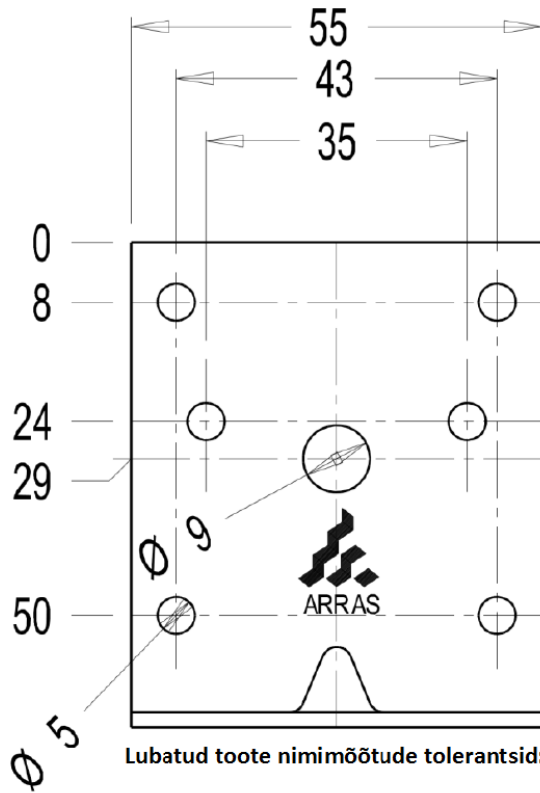

Lubatud toote nimimõõtude tolerantsid:

Haarade pikkused ± 2 mm

Toote samm ± 1 mm

Laius ± 1 mm

Paksus

2,0 mm $\pm 0,15$ mm

2,5 mm $\pm 0,17$ mm

3,0 mm $\pm 0,20$ mm

t 2.5 73624

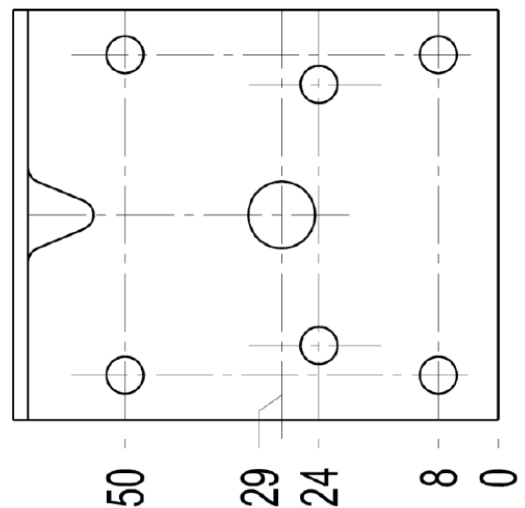
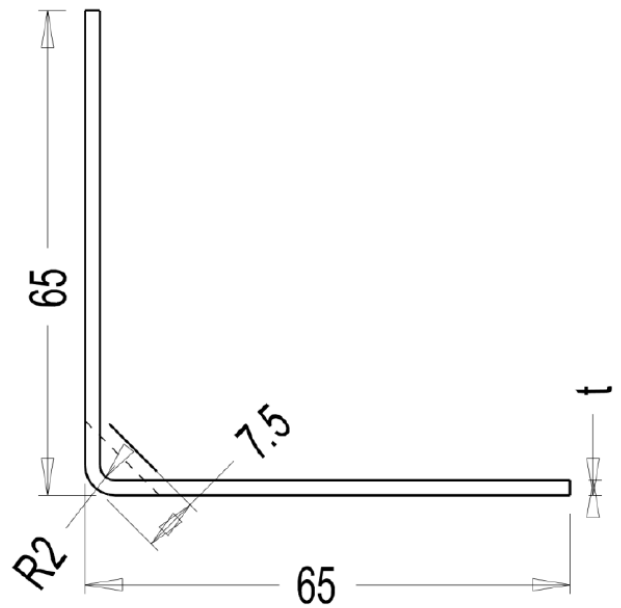

Materjal: HDG DX51D Z275 MAC			Arv: 1 tk.	Mass:	Mõõt: M1:1	A4
Konstruktor	R.K.	14.05.09	Ninetus: Nurgik 65x65x55			
Kontrollis			73624			
		Leht: 1	Tähis: KR 212	Muudat. -XX	Tootekaart	
		Lehti: 1				

3.2

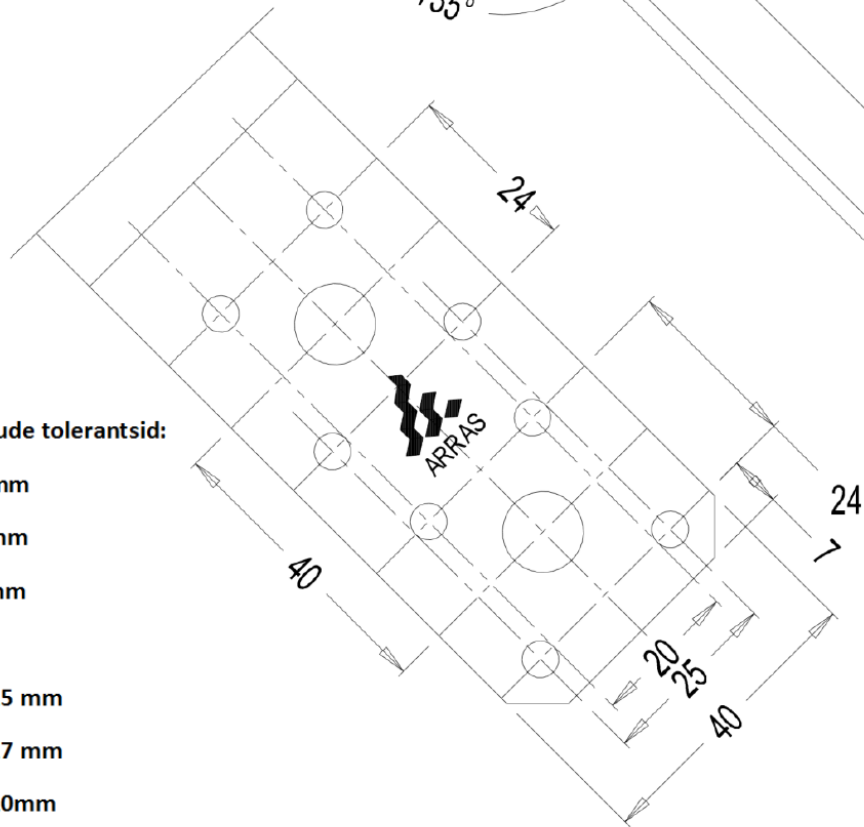
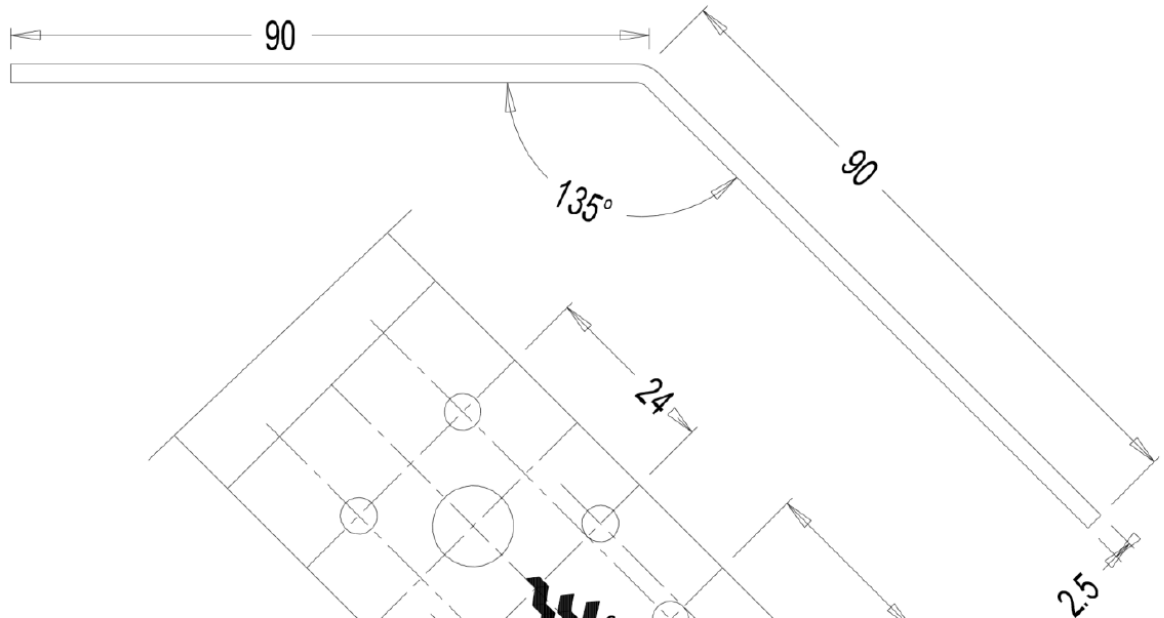
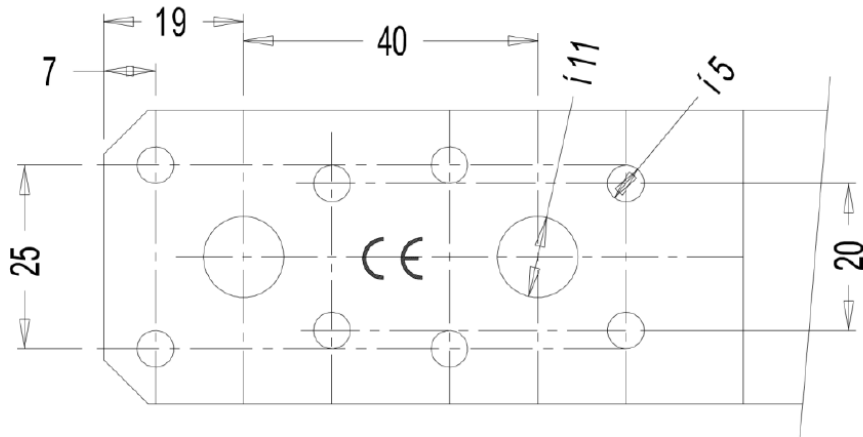

Lubatud toote nimimõõtude tolerantsid:

Haarade pikkused ± 2 mm

Toote samm ± 1 mm

Laius ± 1 mm

Paksus

2,0 mm $\pm 0,15$ mm

2,5 mm $\pm 0,17$ mm

3,0 mm $\pm 0,20$ mm

Materjal: HDG DX51D Z275 MAC			Arv: 1 tk.	Mass:	Mõõt: M1:1	A4
Konstruktor	R.K.	11.06.15	Ninetus: Nurgik 90x90x40x2.5 73104			
Kontrollis						
		Leht: 1	Tähis: KR198		Muudat. -XX	Tootekaart
		Lehti: 1				

ANNEX 1: Product details and definitions

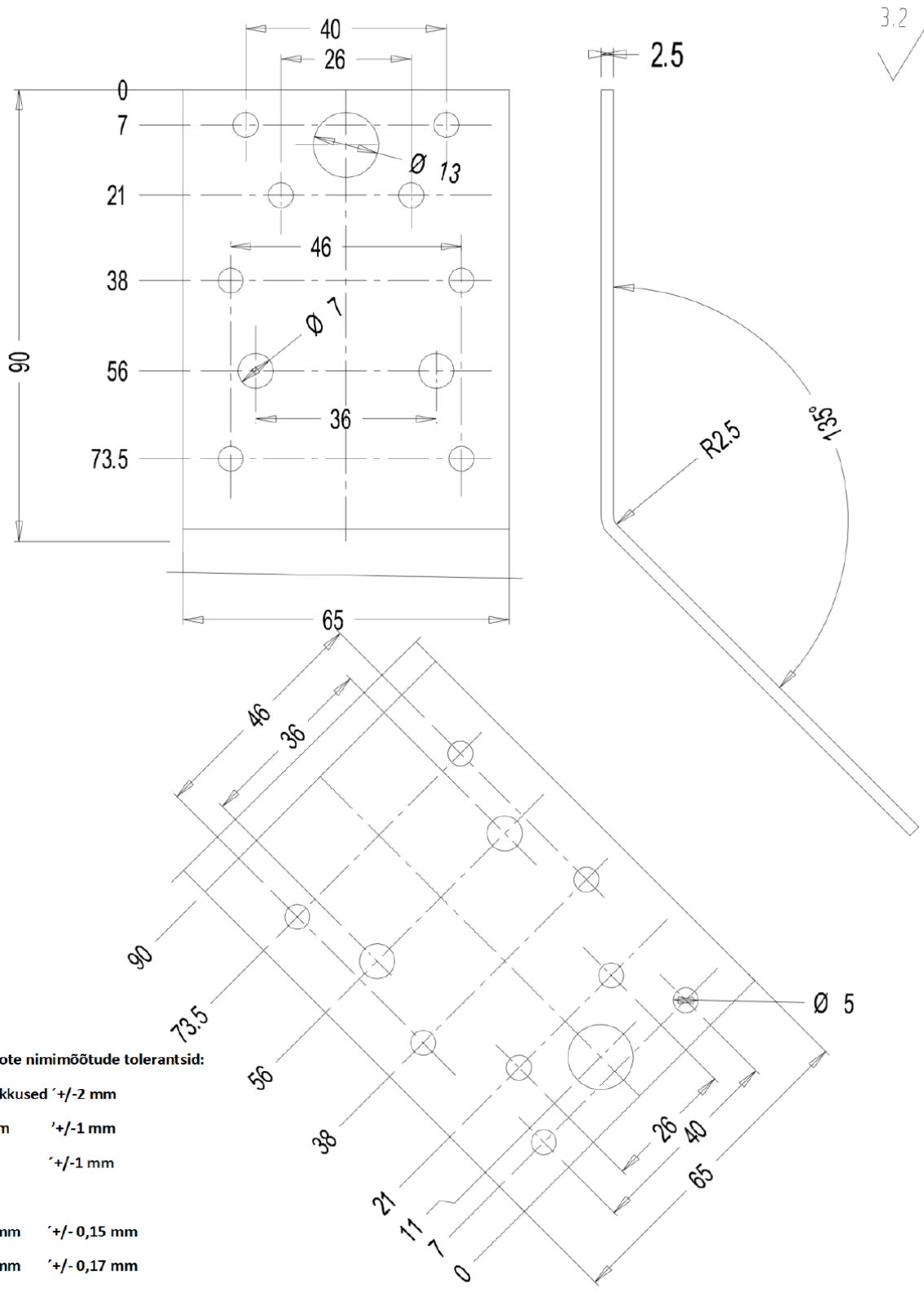

Lubatud toote nimimõõtude tolerantsid:

Haarade pikkused ± 2 mm

Toote samm ± 1 mm

Laius ± 1 mm

Paksus

2,0 mm $\pm 0,15$ mm

2,5 mm $\pm 0,17$ mm

3,0 mm $\pm 0,20$ mm

Materjal: HDG DX 510 Z275 MAC			Arv: X tk.	Mass:	Mõõt: M1:1	A4
Konstruktor	R.K.	16.04.15	Ningetus: Nurgik 90x90x65x2.5 135° 73107			
Kontrollis			Tähis: KR 186		Muudat. -XX	Tootekaart
			Leht: 1			
			Lehti: 1			

3.2

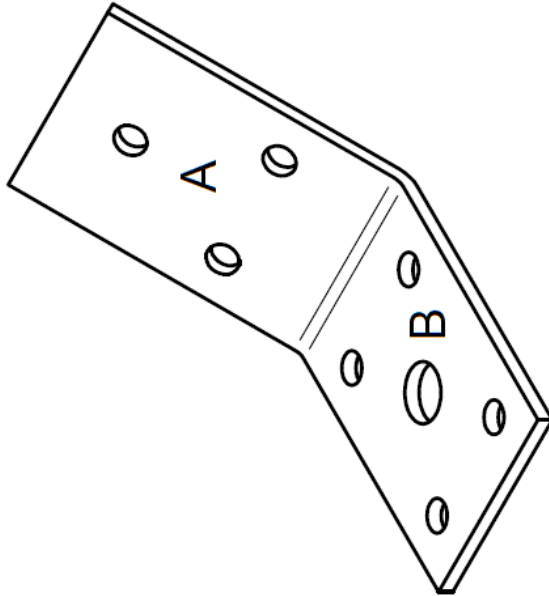

Lubatud toote nimimõõtmiste tolerantsid:
 - Haarade pikkused ± 2 mm
 - Toote samm ± 1 mm
 - Laius ± 1 mm
 - Avad $\pm 0,4$ mm

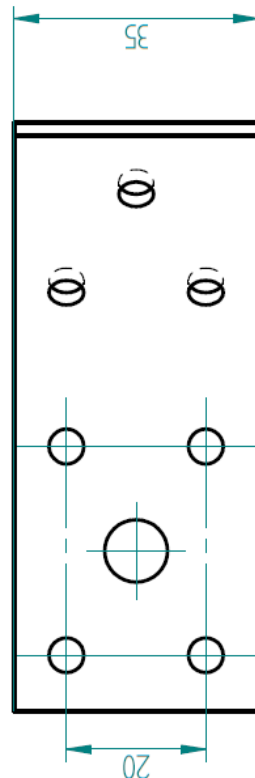
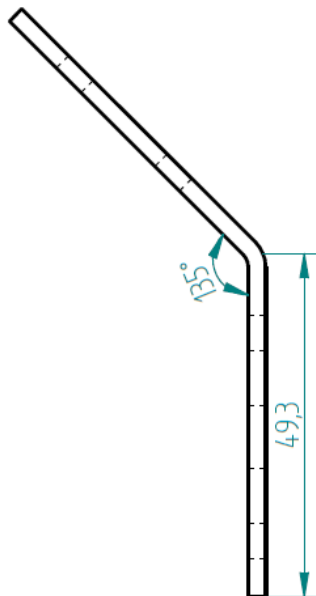

Materjal:	HDG DX 510 Z275	Nimetus:	Nurgik 50x50x35x2,5 135°	
Konstruktor:	M.R.	Artikkel:	73111	Starts: KR-184
Kontrollis:				
Kuupäev:	11.12.2020			
		Lehe mõõt	A4	
		Mõõt:	1:2	Kaal:0,053 kg

ANNEX 1: Product details and definitions

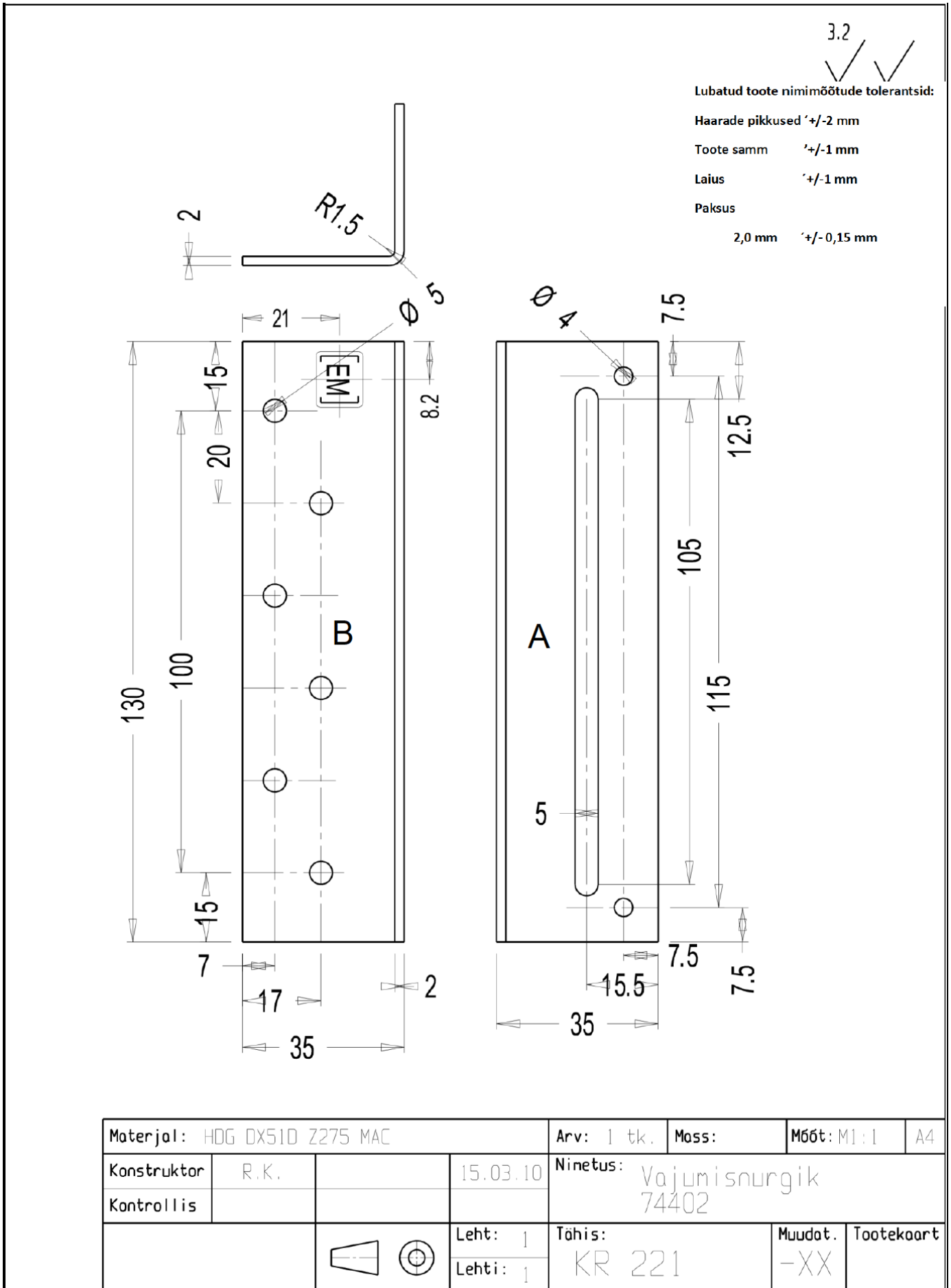

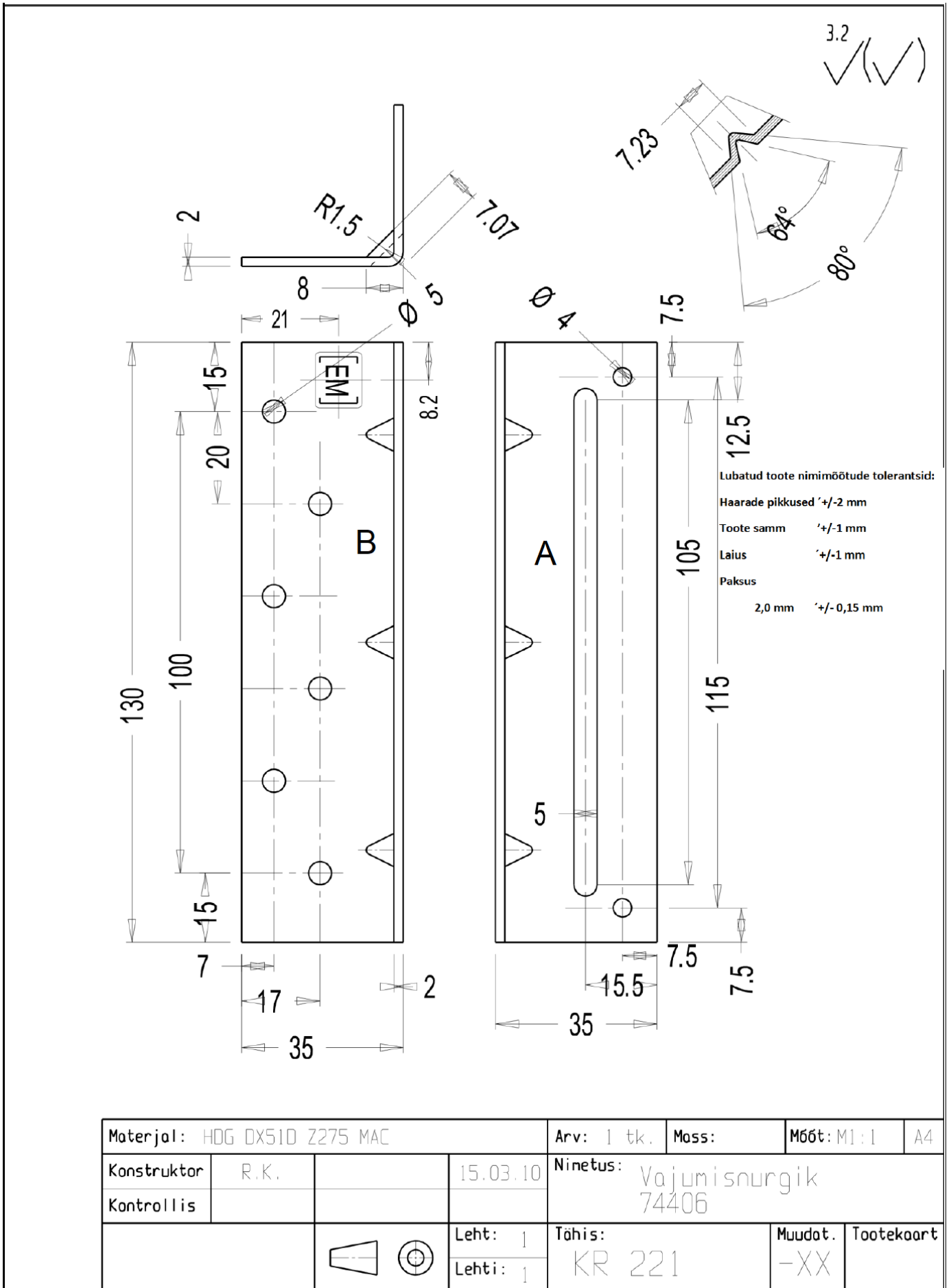

ANNEX 2. CHARACTERISTIC LOAD-CARRYING CAPACITIES

Characteristic resistances for EJOT Angle Brackets - calculation method

Load carrying capacity of non-sliding angle bracket connections

The design resistance R_d of the angle bracket connection is

$$R_d = k_{\text{mod}} \frac{R_k}{\gamma_M} \quad (1)$$

where k_{mod} is the modification factor according to EN 1995-1-1 taking into account the effect of the duration of the load and moisture content for timber, γ_M is the partial factor for the resistance of connections according to the relevant National annex of EN 1995-1-1 and R_k is the characteristic resistance of the angle bracket connection.

When the connection made by the angle bracket is loaded by a shear force at the plane of flange A in the middle of the flange, it shall be checked that the conditions according to equations (2) to (4) are fulfilled

$$F_d \leq R_{A,d} \quad (2)$$

$$F_{x,d} \leq R_{B,x,d} \quad (3)$$

$$F_{z,d} \leq \begin{cases} R_{B,z,t,d} & \text{when the connection is in tension} \\ R_{B,z,c,d} & \text{when the connection is in compression} \end{cases} \quad (4)$$

where $F_{x,d}$ is the component in the direction of the bent edge of the angle bracket from the connection force F_d and $F_{z,d}$ is the component perpendicular to $F_{x,d}$ from the connection force F_d . The obtuse-angled Angle Bracket 135° connectors types 90/40/135° (73104), 90R/135° (73107) and 35/50/135° (73111) may be loaded only by a shear force parallel to the bent edge: $F_d = F_{x,d}$.

In addition, when the connection is loaded in tension, the following interaction equation shall be fulfilled:

$$\left(\frac{F_{z,d}}{R_{B,z,t,d}} \right)^2 + \left(\frac{F_{x,d}}{R_{B,x,d}} \right)^2 \leq 1 \quad (5)$$

Characteristic resistance

$$R_{A,k} = n_A F_{A,v,Rk} \quad (6)$$

where n_A is number of fasteners at flange A. $F_{A,v,Rk}$ is the characteristic lateral load-carrying capacity of the fastener in the timber part against flange A according to EN 1995-1-1, equation (7) for steel plate thickness t less than or equal to $d/2$ and (8) for thicker steel plates of thickness greater than or equal to d :

$$F_{v,Rk} = \min \begin{cases} 0,4 f_{h,k} t_1 d & \text{(a)} \\ 1,15 \sqrt{2 M_{y,Rk} f_{h,k} d} + \frac{F_{ax,Rk}}{4} & \text{(b)} \end{cases} \quad (7)$$

$$F_{v,Rk} = \min \begin{cases} f_{h,k} t_1 d & \text{(a)} \\ f_{h,k} t_1 d \left[\sqrt{2 + \frac{4M_{y,Rk}}{f_{h,k} d t_1^2}} - 1 \right] + \frac{F_{ax,Rk}}{4} & \text{(b)} \\ 2,3 \sqrt{M_{y,Rk} f_{h,k} d} + \frac{F_{ax,Rk}}{4} & \text{(c)} \end{cases} \quad (8)$$

where $t_1 = L - t$ when L is the length of the fastener, t is the thickness of steel plate, $M_{y,k}$ is according to standards EN 14592 and EN 409 experimentally determined characteristic value of the yield moment of the fastener, $F_{ax,Rk}$ is the withdrawal resistance of the fastener according to Eq. (10) limited at maximum to $1/3$ with nails and $1/2$ with screws from the load-carrying capacity $F_{v,Rk}$ and the characteristic value of the embedding strength

$$f_{h,k} = 0,082 \rho_k d^{-0,3} \quad \text{N/mm}^2 \quad (9)$$

The characteristic withdrawal resistance of the nail

$$F_{ax,Rk} = f_{ax,k} d t_{pen} \leq f_{tens,k} \quad (10a)$$

and for the screw

$$F_{ax,Rk} = n^{-0,1} f_{ax,k} d l_{ef} \left(\frac{\rho_k}{\rho_a} \right)^{0,8} \leq n^{-0,1} f_{tens,k} \quad (10b)$$

where $f_{ax,k}$ is the withdrawal parameter determined by testing according to standards EN 14592 and EN 1382 for the actual timber material with density ρ_a , $f_{tens,k}$ is the experimentally determined tensile resistance of the fastener together with a steel plate, t_{pen} is the penetration depth of the profiled part of the nail in timber, n is the number of the screws in the flange of connector, l_{ef} is the length of threaded part of the screw and ρ_k is the characteristic density of timber in the actual connection. If the penetration depth for an anchor nail is less than $t_{pen} \leq 8d = 32$ mm, the resistance according to Eq. (10a) is reduced by $(t_{pen}/8\text{mm} - 3)$.

Eq. (8) may be used for angular ring shank nails, if the length of the conical part is at least 4 mm and the diameter of the cone at the head of the nail is at least 5,2 mm. Otherwise linear interpolation of equations (7) and (8) is used for the steel plate thicknesses between 2 and 4 mm.

Characteristic resistance

$$R_{B,x,k} = k_m F_{B,v,Rk} \quad (11)$$

where $F_{B,v,Rk}$ is the characteristic lateral load-carrying capacity of the fastener in the timber part against flange B, according to EN 1995-1-1, and the factor k_m depends on the placement of the fasteners. Values of k_m are given in Table A2.1 for cases, where fasteners are used in all 5 mm holes of the angle bracket.

Characteristic tension resistance for angular brackets without reinforcement ribs

$$R_{B,z,t,k} = \min \begin{cases} F_{n,1} + F_{n,2} - 3 \cdot \frac{F_{n,1} \cdot d_1 + F_{n,2} \cdot d_2 - \frac{B \cdot t_d^2}{4} \cdot f_y}{2L_B + d_2} & \text{(a)} \\ \frac{t_d^2 f_y}{4 d_1} \cdot (B + B_{net,1}) & \text{(b)} \\ \frac{t_d^2 f_y}{4 d_2} \cdot (B + B_{net,2}) + \frac{F_{n,1} (d_2 - d_1)}{d_2} & \text{(c)} \\ F_{n,1} + F_{n,2} & \text{(d)} \end{cases} \quad (12)$$

where

- d_1 distance between the bent edge and the hole row nearest to it in flange B ($i = 1$),
- d_2 distance between the bent edge and the hole row second nearest to it in flange B ($i = 2$),
- B the width of the angular bracket,
- t_d is the thickness of the Angle Bracket to be used in calculations (= the minimum thickness minus the thickness of the zinc coating),
- f_y yield strength of the steel of the Angle Bracket,
- L_B the length of flange B from the middle of the bent edge,
- $B_{net,i}$ the net width of the Angle Bracket at hole row i and

$$F_{n,i} = n_i F_{ax,Rk} \quad (13)$$

when n_i is the number of fasteners at row i and $F_{ax,Rk}$ is the characteristic withdrawal resistance of the fastener in the timber member against flange B according to EN 1995-1-1.

If there are fasteners only in one or two rows at flange B, in expression (12) equation (a) is inserted by $F_{n,2} = 0$ and $d_2 = d_1$ and equation (c) needs not to be checked.

Characteristic tension resistance for a angle bracket with reinforcement rib

$$R_{B,z,t,k} = \min \left\{ \begin{array}{l} \Sigma F_{a,j} + F_{n,1} - 3 \cdot \frac{F_{n,1} \cdot d_1 - \frac{B \cdot t_d^2}{4} \cdot f_y}{2L_B - 2a + d_2} \quad (a) \\ \max \left\{ \begin{array}{l} \frac{t_d^2 f_y}{4(a + d_1)} \cdot (B + B_{net,1}) + \frac{\Sigma (F_{a,j} (a + d_1 - a_j))}{a + d_1} \quad (b) \\ \Sigma F_{a,j} + F_{n,1} \quad (c) \end{array} \right. \end{array} \right. \quad (14)$$

where

- d_1 distance between the end of the reinforcement fold and the hole row nearest to it in flange B ($i = 1$)
- a is the length of the stiffener ridge in flange B
- a_j is distance between bent edge and the fastener row j
- B the width of the angle bracket at the end of reinforcement rib
- t_d is the thickness of the connector to be used in calculations (= the minimum thickness minus the thickness of the zinc coating)
- f_y yield strength of the steel of the connector
- L_B the length of flange B from the middle of the bent edge
- $B_{net,i}$ the net width of the angle bracket at hole row i

$$F_{n,i} = n_i F_{ax,Rk} \quad (15)$$

$$F_{a,j} = n_j F_{ax,Rk} \quad (16)$$

when n_1 is the number of fasteners in the row nearest to the end of the reinforcement fold (i), n_j is the number of fasteners at row j in the part of flange B with the reinforcement and $F_{ax,Rk}$ is the characteristic withdrawal resistance of the fastener in the timber member against flange B according to EN 1995-1-1.

If the flange B of the connector only has one row of fasteners on the part without stiffener rib, in equation (14) is inserted $F_{n,1} = 0$.

For a stiffened connector that have no fasteners on the reinforcement area, the tension capacity may be calculated as maximum of equations (12) and (14). Then in expression (12), the flange length L_B is taken as distance between the end of the reinforcement rib and the end of the flange.

Characteristic compression resistance for angle brackets without reinforcement

$$R_{B,z,c,k} = t_d \cdot \sqrt{3 \cdot B \cdot B_{\text{net}} \cdot f_y \cdot f_{c,90,k}} \quad (17)$$

where t_d , B and f_y are defined as for equation (12) and B_{net} is the smallest net width of the flange B and $f_{c,90,k}$ is the characteristic compression strength perpendicular to the timber member against flange B .

Characteristic compression resistance for angle brackets with reinforcements

$$R_{z,c,B,k} = 3 \cdot a \cdot B_{\text{ef}} \cdot f_{c,90,k} + t_d \cdot \sqrt{3 \cdot B \cdot B_{\text{net}} \cdot f_y \cdot f_{c,90,k}} \quad (18)$$

where a is the length of the reinforcement rib from the bent edge of the angular bracket, B_{ef} is the width of the angular bracket minus the width of the reinforcement and the other symbols as for equation (17).

Calculated characteristic compression resistances of EJOT Angle Brackets are shown in Tables A2.3 and A2.4 for connections of sawn timber of strength class C24.

For a timber-to-concrete angle bracket connection, the resistance of the corresponding timber-to-timber connection may be used, provided that the lateral load carrying capacity and axial tension capacity of the fastener group of flange B in concrete are greater or equal than the capacities of the fastener group of flange B in timber member.

Load carrying capacity of long adjustable bracket types 35/35/130 (74402) 35/35/130R (74406)

In design of long adjustable hole brackets following condition shall be fulfilled

$$\left(\frac{F_{z,t,d}}{R_{B,z,t,d}} \right)^2 + \left(\frac{F_{y,t,d}}{R_{A,y,t,d}} \right)^2 \leq 1 \quad (19)$$

where $F_{z,t,d}$ is the design tension load perpendicular to flange B and $F_{y,t,d}$ is the design tension load perpendicular to the sliding flange A .

The design capacities are as follows

$$R_{B,z,t,d} = \min \left\{ \begin{array}{l} \frac{k_{\text{mod}} \cdot R_{t,z,k}}{\gamma_M} \\ \frac{k_{\text{mod}} \cdot R_{v,z,k}}{\gamma_M} \\ \frac{R_{b,z,k}}{\gamma_{M,1}} \end{array} \right. \quad (20)$$

$$R_{A,y,t,d} = \min \left\{ \begin{array}{l} \frac{k_{\text{mod}} \cdot R_{t,y,k}}{\gamma_M} \\ \frac{k_{\text{mod}} \cdot R_{v,y,k}}{\gamma_M} \\ \frac{R_{t,y,k}}{\gamma_{M,1}} \end{array} \right. \quad (21)$$

where $\gamma_{M,1}$ is the partial safety factor in accordance with the relevant national annex of standard EN 1993-1-3, k_{mod} is the modification factor for load duration and moisture content according to EN 1995-1-1 and γ_M is the partial safety factor of connection in accordance with the relevant national annex of standard EN 1995-1-1.

The characteristic lateral load capacities of the fastener connections are as follows

$$R_{v,z,k} = F_{v,A,Rk} \quad (22)$$

$$R_{v,y,k} = 2,213F_{v,B,Rk} \quad (23)$$

$$R_{b,z,k} = 824 \text{ N} \quad (24)$$

where $F_{v,A,Rk}$ is the lateral load-carrying capacity per fastener in the sliding part and $F_{v,B,Rk}$ is similarly the load-carrying capacity per fastener in nailing plate side, see equations (7) and (8).

The characteristic capacities for bracket type 35/35/130 (74402) are as follows:

$$R_{t,z,k} = \min \begin{cases} 1,2F_{ax,B,Rk} + 939 \text{ N} \\ 6F_{ax,B,Rk} \end{cases} \quad (25)$$

$$R_{t,y,k} = \min \begin{cases} 0,358F_{ax,A,Rk} + 923 \text{ N} \\ F_{ax,A,Rk} \end{cases} \quad (26)$$

$$R_{t,y,k} = 1807 \text{ N} \quad (27)$$

where $F_{ax,A,Rk}$ is the withdrawal capacity of the sliding fastener and $F_{ax,B,Rk}$ is the withdrawal capacity of nailing plate side fastener, see equations (10a) and (10b).

The characteristic capacities for bracket type 35/35/130R (74406) are respectively:

$$R_{t,z,k} = \min \begin{cases} 1,672F_{ax,B,Rk} + 1309 \text{ N} \\ 6F_{ax,B,Rk} \end{cases} \quad (28)$$

$$R_{t,y,k} = \min \begin{cases} 0,496F_{ax,A,Rk} + 1278 \text{ N} \\ F_{ax,A,Rk} \end{cases} \quad (29)$$

$$R_{t,y,k} = 3413 \text{ N} \quad (30)$$

Structural requirements

Connections with the angle brackets shall fulfil the minimum spacing and edge and end distance requirements specified in EN 1995-1-1. The minimum distances a_1 and a_2 in table 8.2 of EN 1995-1-1 can be multiplied by a factor of 0,7 (nailed steel-to-timber connections).

If angle brackets are placed on both sides of the timber, the point of the fastener shall be at most $4d$ from the surface of the opposing side, where d is the nominal diameter of the fastener.

It is not possible to fill all holes by fasteners in all configurations and loading combinations of the angle brackets. In partial fixing the fasteners shall always be placed in the row nearest to the end of the flange and as near as possible to the bent edge of the angle bracket. Additionally, the fasteners should be positioned symmetrically.

The sliding angle brackets are always fixed from all holes of 5 mm diameter.

All fasteners in same flange shall be identical. The opposing flanges may have different fasteners.

Table A2.1. Article numbers of the non-sliding EJOT Angle Brackets, nominal dimensions, grade of steel plate, number of fasteners in flange B n_B , eccentricity of the fastener group e , sum of the moment arms for the fastener group Σr_i and values for factor k_m when the fasteners are used in all 5 mm diameter of holes.

Product type name	Art. No.	Size (mm)	Grade	n_B	e (mm)	Σr_i (mm)	k_m
angle bracket 30	71101	30x30x25x2,0	DX51D	2	20,0	16,1	0,645
angle bracket 35/50	71102	50x50x35x2,0	DX51D	4	25,5	72,1	1,729
angle bracket 65	71103	65x65x55x2,0	DX51D	6	36,7	155,9	2,673
angle bracket 70	71104	70x70x55x2,0	DX51D	10	38,6	222,1	3,653
angle bracket type 90/40/2,5	71105	90x90x40x2,5	DX51D	8	49,8	191,1	2,621
angle bracket 100	71107	100x100x55x2,5	DX51D	9	56,3	319,0	3,552
angle bracket 50	71109	50x50x55x2,5	DX51D	4	26,8	93,8	2,144
angle bracket 105	71112	105x105x90x2,0	DX51D	11	50,1	416,6	4,735
angle bracket 90	71115	90x90x65x2,0	DX51D	8	54,1	241,3	2,958
angle bracket type 40/50	71116	50x50x40x2,0	DX51D	4	30,0	65,9	1,500
angle bracket type 90/40/2	71127	90x90x40x2,0	DX51D	8	50,0	185,5	2,554
angle bracket 100	71131	100x100x55x2,0	DX51D	9	56,5	319,0	3,543
angle bracket 120	71132	120x120x90x2,5	DX51D	11	49,9	416,3	4,745
angle bracket type 90/40/2,5/A2	71210	90x90x40x2,5	A2, AISI 304	8	49,8	191,1	2,621
angle bracket 70R	71304	70x70x55x2,0	DX51D	9	40,8	202,4	3,412
angle bracket 105R	71305	105x105x90x2,0	DX51D	10	51,8	399,4	4,494
angle bracket 120R	71306	120x120x90x2,5	DX51D	10	51,6	399,4	4,507
angle bracket 140R	71307	140x140x90x2,5	DX51D	13	69,4	614,8	5,351
angle bracket 90R	71308	90x90x65x2,0	DX51D	8	54,1	243,0	2,974
angle bracket 90/90R	71311	90x90x90x2,5	DX51D	8	41,0	287,4	3,951
angle bracket 40/40/2	71320	40x40x40x2,0	DX 51D	4	21,0	68,8	2,023
angle bracket 40/40/2,5	71321	40x40x40x2,5	DX51D	4	20,8	68,8	2,037
angle bracket type 60/40/2	71322	60x60x40x2,0	DX51D	6	31,0	125,7	2,532
angle bracket type 60/40/2,5	71323	60x60x40x2,5	DX51D	6	30,8	125,7	2,544
angle bracket type 80/40/2	71324	80x80x40x2,0	DX51D	8	41,5	201,2	3,088
angle bracket type 80/40/2,5	71325	80x80x40x2,5	DX51D	8	41,3	201,2	3,100
angle bracket type 100/40/2	71326	100x100x40x2,0	DX51D	10	51,5	295,2	3,692
angle bracket type 100/40/2,5	71327	100x100x40x2,5	DX51D	10	51,3	295,5	3,703

Product type name	Art. No.	Size (mm)	Grade	n_B	e (mm)	Σn (mm)	k_m
angle bracket type 40/120/2	71328	120x80x40x2,0	DX51D	8	41,5	201,2	3,088
angle bracket type 40/120/2,5	71329	120x80x40x2,5	DX51D	8	41,3	201,2	3,100
angle bracket type 40/160/2	71332	160x40x40x2,0	DX51D	4	21,5	68,8	1,996
angle bracket type 40/160/2,5	71333	160x40x40x2,5	DX51D	4	21,3	68,8	2,010
angle bracket type 40/200/2,5	71335	200x40x40x2,5	DX51D	4	21,3	68,8	2,010
angle bracket 90R	71340	90x90x65x2,0	DX51D	8	48,3	233,6	3,100
angle bracket 90	71345	90x90x65x2,0	DX51D	11	44,2	282,8	4,046
angle bracket type 20/40	71402	40x40x20x2,0	DX51D	2	20,2	22,8	0,744
angle bracket 90R/2,5 A4	71460	90x90x65x2,5	A4, AISI 316	8	53,9	243,0	2,983
angle bracket 40 A4	71461	40x40x40x2,0	A4, AISI 316	4	21,0	58,4	1,684
angle bracket 50/2,0 A4	71462	50x50x35x2,0	A4, AISI 316	4	25,5	72,1	1,729
angle bracket 90 A4	71463	90x90x65x2,5	A4, AISI 316	8	53,9	243,0	2,983
angle bracket type 40/60 A4	71464	60x60x40x2,0	A4, AISI 316	6	31,0	110,2	2,260
angle bracket 70R A4	71465	70x70x55x2,5	A4, AISI 316	9	40,5	202,4	3,425
angle bracket 50/2,5 A4	71466	50x50x35x2,5	A4, AISI 316	4	25,3	72,1	1,739
angle bracket type 60/60/2 A4	71467	60x60x60x2,0	A4, AISI 316	9	31,0	200,8	3,779
angle bracket 90R/2,0 A4	71468	90x90x65x2,0	A4, AISI 316	8	54,1	243,0	2,974
angle bracket 105R/2,5 A4	71469	105x105x90x2,5	A4, AISI 316	10	51,6	399,4	4,507
angle bracket 105/2,5 A4	71470	105x105x90x2,5	A4, AISI 316	11	49,9	416,6	4,748
angle bracket type 80/60	71502	80x60x60x2,5	DX51D	9	28,8	200,8	3,945
angle bracket type 60/160/2,5	71506	160x80x60x2,5	DX51D	12	41,3	318,3	4,712
angle bracket type 80/160/2,5	71507	160x80x80x2,5	DX51D	16	41,3	483,3	6,786
angle bracket type 100/200	71510	200x100x100x2,5	DX51D	25	46,8	945,8	11,200
angle bracket type 60/60	71512	60x40x60x2,5	DX51D	6	18,8	106,6	2,989
facade corner 150/90	71551	150x90x65x2,5	DX51D	6	62,8	149,6	1,885
facade corner 170/90	71552	170x90x65x2,5	DX51D	6	62,8	149,6	1,885
facade corner 190/90	71553	190x90x65x2,5	DX51D	6	62,8	149,6	1,885
facade corner 150/150	71554	150x150x65x2,5	DX51D	10	85,8	361,2	3,065
facade corner 170/170	71555	170x170x65x2,5	DX51D	12	98,4	514,5	3,699
facade corner 190/190	71556	190x190x65x2,5	DX51D	15	114,6	758,2	4,628
angle bracket type 40/90	73001	90x40x40x2,5	DX51D	2	17,8	20,0	0,982
angle bracket type 40/140	73002	140x40x40x2,5	DX51D	4	21,3	62,6	1,782

Product type name	Art. No.	Size (mm)	Grade	n_B	e (mm)	Σn (mm)	k_m
angle bracket type 55/90	73006	90x50x55x2,5	DX51D	7	26,8	139,5	3,119
angle bracket type 40/90/3	73007	90x40x40x3,0	DX51D	2	17,5	20,0	0,992
angle bracket type 20/180	73201	180x20x40x2,0	DX51D	2	9,0	20,0	1,487
angle bracket type 20/280	73202	280x20x40x2,0	DX51D	2	9,0	20,0	1,487
angle bracket type 20/380	73203	380x20x40x2,0	DX51D	2	9,0	20,0	1,487
angle bracket type 90/40/2,5R	73605	90x90x40x2,5	DX51D	8	49,8	191,1	2,621
angle bracket type 40/140/2,5R	73606	140x40x40x2,5	DX51D	4	21,3	65,9	1,856
angle bracket 50R	73609	50x50x55x2,5	DX51D	4	26,8	93,8	2,144
angle bracket 65R	73610	65x65x55x2,0	DX51D	6	36,7	155,9	2,673
angle bracket 40/50/2R	73612	50x50x40x2,0	DX51D	4	30,0	65,9	1,500
angle bracket 40/50/2,5R	73622	50x50x40x2,5	DX51D	4	29,8	65,9	1,508
angle bracket 65/3R	73623	65x65x55x3,0	DX51D	6	36,2	155,9	2,695
angle bracket 65/2,5R	73624	65x65x55x2,5	DX51D	6	36,4	155,9	2,684
angle bracket type 90/40/135°	73104	90x90x40x2,5	DX51D	8	87,1	191,1	1,736
angle bracket 90R/135°	73107	90x90x65x2,5	DX51D	8	94,1	243,0	2,005
angle bracket 35/50/135°	73111	50x50x35x2,5	DX51D	4	50,3	72,1	1,092

Table A2.2. Article numbers of the sliding EJOT Angle Brackets and their nominal dimensions, types and number of fasteners in flanges A and B.

Product type name	Art. No.	Size (mm)	Type	n_A	n_B
angle bracket 35/35/130	74402	35x35x130x2,0	non-reinforced	1	6
angle bracket 35/35/130R	74406	35x35x130x2,0	stiffened by 3 ribs	1	6

Table A2.3. Characteristic compression resistance $R_{B,z,c,k}$ for unreinforced EJOT Angle Brackets used with sawn timber in strength class C24. For compression capacities with other strength classes, the characteristic resistance $R_{B,z,c,k}$ should be multiplied by the factor $\sqrt{f_{c,90,k}}/2,5$, where $f_{c,90,k}$ is the characteristic compression strength perpendicular to the grain of the actual timber grade in N/mm².

Product type name	Art. No.	Size (mm)	f_y (N/mm ²)	t_d (mm)	B (mm)	B_{net} (mm)	$R_{B,z,c,k}$ (kN)
angle bracket 30	71101	30x30x25x2,0	250	1,81	25	20	1,75
angle bracket 35/50	71102	50x50x35x2,0	250	1,81	35	25	2,32
angle bracket 65	71103	65x65x55x2,0	250	1,81	55	45	3,90
angle bracket 70	71104	70x70x55x2,0	250	1,81	55	34	3,39
angle bracket type 90/40/2,5	71105	90x90x40x2,5	250	2,29	40	29	3,38
angle bracket 100	71107	100x100x55x2,5	250	2,29	55	40	4,65
angle bracket 50	71109	50x50x55x2,5	250	2,29	55	45	4,93
angle bracket 105	71112	105x105x90x2,0	250	1,81	90	63	5,90
angle bracket 90	71115	90x90x65x2,0	250	1,81	65	51	4,51
angle bracket type 40/50	71116	50x50x40x2,0	250	1,81	40	29	2,67
angle bracket type 90/40/2	71127	90x90x40x2,0	250	1,81	40	29	2,67
angle bracket 100	71131	100x100x55x2,0	250	1,81	55	40	3,68
angle bracket 120	71132	120x120x90x2,5	250	2,29	90	63	7,47
angle bracket type 90/40/2,5/A2	71210	90x90x40x2,5	220	2,38	40	29	3,29
angle bracket 40/40/2	71320	40x40x40x2,0	250	1,81	40	29	2,67
angle bracket 40/40/2,5	71321	40x40x40x2,5	250	2,29	40	29	3,38
angle bracket type 60/40/2	71322	60x60x40x2,0	250	1,81	40	29	2,67
angle bracket type 60/40/2,5	71323	60x60x40x2,5	250	2,29	40	29	3,38
angle bracket type 80/40/2	71324	80x80x40x2,0	250	1,81	40	29	2,67
angle bracket type 80/40/2,5	71325	80x80x40x2,5	250	2,29	40	29	3,38
angle bracket type 100/40/2	71326	100x100x40x2,0	250	1,81	40	29	2,67
angle bracket type 100/40/2,5	71327	100x100x40x2,5	250	2,29	40	29	3,38
angle bracket type 40/120/2	71328	120x80x40x2,0	250	1,81	40	29	2,67
angle bracket type 40/120/2,5	71329	120x80x40x2,5	250	2,29	40	29	3,38
angle bracket type 40/160/2	71332	160x40x40x2,0	250	1,81	40	29	2,67
angle bracket type 40/160/2,5	71333	160x40x40x2,5	250	2,29	40	29	3,38
angle bracket type 40/200/2,5	71335	200x40x40x2,5	250	2,29	40	29	3,38
angle bracket 90	71345	90x90x65x2,0	250	1,81	65	45	4,24
angle bracket type 20/40	71402	40x40x20x2,0	250	1,81	20	15	1,36

Product type name	Art. No.	Size (mm)	f_y (N/mm ²)	t_d (mm)	B (mm)	B_{net} (mm)	$R_{B,z,c,k}$ (kN)
angle bracket 40 A4	71461	40x40x40x2,0	240	1,90	40	30	2,79
angle bracket 50/2,0 A4	71462	50x50x35x2,0	240	1,90	35	25	2,38
angle bracket 90 A4	71463	90x90x65x2,5	240	2,38	65	51	5,81
angle bracket type 40/60 A4	71464	60x60x40x2,0	240	1,90	40	30	2,79
angle bracket 50/2,5 A4	71466	50x50x35x2,5	240	2,38	35	25	2,99
angle bracket type 60/60/2 A4	71467	60x60x60x2,0	240	1,90	60	45	4,19
angle bracket 105/2,5 A4	71470	105x105x90x2,5	240	2,38	90	63	7,60
angle bracket type 80/60	71502	80x60x60x2,5	250	2,29	60	45	5,15
angle bracket type 60/160/2,5	71506	160x80x60x2,5	250	2,29	60	45	5,15
angle bracket type 80/160/2,5	71507	160x80x80x2,5	250	2,29	80	60	6,87
angle bracket type 100/200	71510	200x100x100x2,5	250	2,29	100	75	8,59
angle bracket type 60/60	71512	60x40x60x2,5	250	2,29	60	45	5,15
angle bracket type 40/90	73001	90x40x40x2,5	250	2,29	40	29	3,38
angle bracket type 40/140	73002	140x40x40x2,5	250	2,29	40	29	3,38
angle bracket type 55/90	73006	90x50x55x2,5	250	2,29	55	34	4,29
angle bracket type 40/90/3	73007	90x40x40x3,0	250	2,76	40	29	4,07
angle bracket type 20/180	73201	180x20x40x2,0	250	1,81	40	30	2,72
angle bracket type 20/280	73202	280x20x40x2,0	250	1,81	40	30	2,72
angle bracket type 20/380	73203	380x20x40x2,0	250	1,81	40	30	2,72

Table A2.4. Characteristic compression resistance $R_{B,z,c,k}$ for reinforced EJOT Angle Brackets used with sawn timber in strength class C24. For compression capacities with other strength classes, the characteristic resistance $R_{B,z,c,k}$ should be multiplied by the factor $\sqrt{f_{c,90,k}}/2,5$, where $f_{c,90,k}$ is the characteristic compression strength perpendicular to the grain of the actual timber grade.

Product type name	Art. No.	Size (mm)	f_y (N/mm ²)	t_d (mm)	B (mm)	a (mm)	B_{ef} (mm)	B_{net} (mm)	$R_{B,z,c,k}$ (kN)
angle bracket 70R	71304	70x70x55x2,0	250	1,81	55	36,5	33	35	12,5
angle bracket 105R	71305	105x105x90x2,0	250	1,81	90	76	55	68	37,5
angle bracket 120R	71306	120x120x90x2,5	250	2,29	90	76,3	55	68	39,2
angle bracket 140R	71307	140x140x90x2,5	250	2,29	90	76,3	55	68	39,2
angle bracket 90R	71308	90x90x65x2,0	250	1,81	65	55	31	44	17,0
angle bracket 90/90R	71311	90x90x90x2,5	250	2,29	90	76,3	55	68	31,5
angle bracket 90R	71340	90x90x65x2,0	250	1,81	65	55	31	45	17,0
angle bracket 90R/2,5 A4	71460	90x90x65x2,5	240	2,38	65	45	40	45	19,0
angle bracket 70R A4	71465	70x70x55x2,5	240	2,38	55	36,3	31	35	12,9
angle bracket 90R/2,0 A4	71468	90x90x65x2,0	240	2,38	65	55	31	45	18,2
angle bracket 105R/2,5 A4	71469	105x105x90x2,5	240	2,38	90	65	60	70	37,3
facade corner 150/90	71551	150x90x65x2,5	250	2,29	65	71,3	48	44	25,7
facade corner 170/90	71552	170x90x65x2,5	250	2,29	65	71,3	48	44	25,7
facade corner 190/90	71553	190x90x65x2,5	250	2,29	65	71,3	48	44	25,7
facade corner 150/150	71554	150x150x65x2,5	250	2,29	65	71,3	48	44	30,9
facade corner 170/170	71555	170x170x65x2,5	250	2,29	65	71,3	48	44	30,9
facade corner 190/190	71556	190x190x65x2,5	250	2,29	65	71,3	48	44	30,9
angle bracket type 90/40/2,5R	73605	90x90x40x2,5	250	2,29	40	9	29	29	5,3
angle bracket type 40/140/2,5R	73606	140x40x40x2,5	250	2,29	40	9	29	29	5,3
angle bracket 50R	73609	50x50x55x2,5	250	2,29	55	9	44	45	7,9
angle bracket 65R	73610	65x65x55x2,0	250	1,81	55	9	44	45	6,9
angle bracket 40/50/2R	73612	50x50x40x2,0	250	1,81	40	9	29	29	4,6
angle bracket 40/50/2,5R	73622	50x50x40x2,5	250	2,29	40	9	29	29	5,3
angle bracket 65/3R	73623	65x65x55x3,0	250	2,76	55	9	44	45	8,9
angle bracket 65/2,5R	73624	65x65x55x2,5	250	2,29	55	9	44	45	7,9

Table A2.5. Characteristic tension resistance $R_{B,z,t,k}$ for unreinforced EJOT Angle Bracket connections when anchor nails 4x50, $f_{ax,k} = 6 \text{ N/mm}^2$ and $t_{pen} = 34 \text{ mm}$, are used in all holes.

Product type name	Art. No.	Size (mm)	L_B (mm)	d_1 (mm)	n_1	$B_{net,1}$ (mm)	$F_{n,1}$ (N)	d_2 (mm)	n_2	$B_{net,2}$ (mm)	$F_{n,2}$ (N)	$F_{z,t,k}$ (a) (N)	$F_{z,t,k}$ (b) (N)	$F_{z,t,k}$ (c) (N)	$F_{z,t,k}$ (d) (N)	$R_{B,z,t,k}$ (kN)
angle bracket 30	71101	30x30x25x2,0	29	16	1	20	816	24	0	20	0	526	576	656	816	0,53
angle bracket 35/50	71102	50x50x35x2,0	48,5	10,5	2	25	1632	40,5	0	25	0	1414	1170	1512	1632	1,17
angle bracket 65	71103	65x65x55x2,0	64	14	2	45	1632	40	2	45	1632	1891	1463	1573	3264	1,46
angle bracket 70	71104	70x70x55x2,0	71	21	3	40	2448	34	2	45	1632	2450	926	1538	4080	0,93
angle bracket type 90/40/2,5	71105	90x90x40x2,5	88,75	17,75	2	30	1632	41,75	2	30	1632	2115	1293	1488	3264	1,29
angle bracket 100	71107	100x100x55x2,5	98,75	11,75	2	45	1632	31,75	2	45	1632	2571	2789	2060	3264	2,06
angle bracket 50	71109	50x50x55x2,5	48,75	13,75	2	45	1632	39,75	0	45	0	1536	2384	1892	1632	1,54
angle bracket 105	71112	105x105x90x2,0	104	15,75	4	70	3264	33,25	1	63	816	3332	2080	2660	4080	2,08
angle bracket 90	71115	90x90x65x2,0	89	15,5	2	55	1632	51	2	55	1632	2017	1585	1618	3264	1,59
angle bracket type 40/50	71116	50x50x40x2,0	49	18	2	30	1632	42	0	30	0	1178	796	1274	1632	0,80
angle bracket type 90/40/2	71127	90x90x40x2,0	89	18	2	30	1632	42	2	30	1632	2040	796	1274	3264	0,80
angle bracket 100	71131	100x100x55x2,0	99	11,5	2	45	1632	31,5	2	45	1632	2494	1780	1686	3264	1,69
angle bracket 120	71132	120x120x90x2,5	118,75	15,5	4	70	3264	33	1	63	816	3547	3383	3251	4080	3,25
angle bracket type 90/40/2,5/A2	71210	90x90x40x2,5	88,5	17,75	2	30	1632	41,75	2	20	1632	2103	1229	1386	3264	1,23
angle bracket 40/40/2	71320	40x40x40x2,0	39	11	2	30	1632	31	0	30	0	1363	1303	1515	1632	1,30
angle bracket 40/40/2,5	71321	40x40x40x2,5	38,75	10,75	2	30	1632	30,75	0	30	0	1509	2134	1808	1632	1,51
angle bracket type 60/40/2	71322	60x60x40x2,0	59	11	2	30	1632	31	2	30	1632	2049	1303	1515	3264	1,30
angle bracket type 60/40/2,5	71323	60x60x40x2,5	58,75	10,75	2	30	1632	30,75	2	30	1632	2159	2134	1808	3264	1,81
angle bracket type 80/40/2	71324	80x80x40x2,0	79	11,5	2	30	1632	31,5	2	30	1632	2283	1246	1491	3264	1,25
angle bracket type 80/40/2,5	71325	80x80x40x2,5	78,75	11,25	2	30	1632	31,25	2	30	1632	2370	2039	1779	3264	1,78
angle bracket type 100/40/2	71326	100x100x40x2,0	99	11,5	2	30	1632	31,5	2	30	1632	2454	1246	1491	3264	1,25
angle bracket type 100/40/2,5	71327	100x100x40x2,5	88,75	11,25	2	30	1632	31,25	2	30	1632	2456	2039	1779	3264	1,78
angle bracket type 40/120/2	71328	120x80x40x2,0	79	11,5	2	30	1632	31,5	2	30	1632	2283	1246	1491	3264	1,25
angle bracket type 40/120/2,5	71329	120x80x40x2,5	78,75	11,25	2	30	1632	30,75	2	30	1632	2381	2039	1781	3264	1,78
angle bracket type 40/160/2	71332	160x40x40x2,0	39	11,5	2	30	1632	31,5	0	30	0	1342	1246	1491	1632	1,25
angle bracket type 40/160/2,5	71333	160x40x40x2,5	38,75	11,25	2	30	1632	31,25	0	30	0	1487	2039	1779	1632	1,49
angle bracket type 40/200/2,5	71335	200x40x40x2,5	38,75	11,25	2	30	1632	31,25	0	30	0	1487	2039	1779	1632	1,49
angle bracket 90	71345	90x90x65x2,0	89	14	3	55	2448	36	3	55	2448	3367	1755	2179	4896	1,76
angle bracket type 20/40	71402	40x40x20x2,0	39	10,2	1	15	816	31,2	0	15	0	953	703	779	816	0,70

Product type name	Art. No.	Size (mm)	L_B (mm)	d_1 (mm)	n_1	$B_{net,1}$ (mm)	$F_{n,1}$ (N)	d_2 (mm)	n_2	$B_{net,2}$ (mm)	$F_{n,2}$ (N)	$F_{z,t,k}$ (a) (N)	$F_{z,t,k}$ (b) (N)	$F_{z,t,k}$ (c) (N)	$F_{z,t,k}$ (d) (N)	$R_{B,z,t,k}$ (kN)
angle bracket 40 A4	71461	40x40x40x2,0	39	11	2	30	1632	31	0	30	0	1376	1378	1542	1632	1,38
angle bracket 50/2,0 A4	71462	50x50x35x2,0	48,5	10,5	2	25	1632	40,5	0	25	0	1549	1238	1530	1632	1,24
angle bracket 90 A4	71463	90x90x65x2,5	88,75	15,25	2	55	1632	50,75	2	55	1632	2139	2674	1945	3264	1,95
angle bracket type 40/60 A4	71464	60x60x40x2,0	59	11	2	30	1632	31	2	30	1632	2058	1378	1542	3264	1,38
angle bracket 50/2,5 A4	71466	50x50x35x2,5	48,25	10,25	2	25	1632	40,25	0	25	0	1557	1989	1723	1632	1,56
angle bracket type 60/60/2 A4	71467	60x60x60x2,0	59	11	3	45	2448	31	3	45	2448	3088	2068	2313	4896	2,07
angle bracket 105/2,5 A4	71470	105x105x90x2,5	103,75	15,5	4	70	3264	33	1	63	816	3495	3508	3307	4080	3,31
angle bracket type 80/60	71502	80x60x60x2,5	58,75	8,75	3	45	2448	28,75	3	45	2448	3416	3933	2900	4896	2,90
angle bracket type 60/160/2,5	71506	160x80x60x2,5	78,75	11,25	3	45	2448	31,25	3	45	2448	3454	3059	2668	4896	2,67
angle bracket type 80/160/2,5	71507	160x80x80x2,5	78,75	11,25	4	60	3264	31,25	4	60	3264	4535	4079	3557	6528	3,56
angle bracket type 100/200	71510	200x100x100x2,5	98,75	8,75	5	75	4080	28,75	5	75	4080	6566	6555	4833	8160	4,83
angle bracket type 60/60	71512	60x40x60x2,5	38,75	8,75	3	45	2448	28,75	0	45	0	2219	3933	2900	2448	2,22
angle bracket type 40/90	73001	90x40x40x2,5	38,75	19	2	30	1632					939	1208		1632	0,94
angle bracket type 40/140	73002	140x40x40x2,5	40,25	9,25	2	30	1632	33,25	0	30	0	1580	2480	1868	1632	1,58
angle bracket type 55/90	73006	90x50x55x2,5	48,75	11,75	2	45	1632	23,75	2	34	1632	2277	2789	2053	3264	2,05
angle bracket type 40/90/3	73007	90x40x40x3,0	38,5	17,5	2	30	1632				0	1038	1904		1632	1,04
angle bracket type 20/180	73201	180x20x40x2,0	19	9	2	30	1632				0	1523	1593		1632	1,52
angle bracket type 20/280	73202	280x20x40x2,0	19	9	2	30	1632				0	1119	1593		1632	1,12
angle bracket type 20/380	73203	380x20x40x2,0	19	9	2	30	1632				0	1119	1593		1632	1,12

Table A2.6. Characteristic tension resistance $R_{B,z,t,k}$ for reinforced EJOT Angle Bracket connections when anchor nails 4x50, $f_{ax,k} = 6 \text{ N/mm}^2$ and $t_{pen} = 34 \text{ mm}$, are used in all holes.

Tension resistances according to equation (14):

Product type name	Art. No.	Size (mm)	L_B (mm)	a (mm)	a_1 (mm)	n_{a1}	$F_{a,1}$ (N)	a_2 (mm)	n_{a2}	$F_{a,2}$ (N)	d_1 (mm)	n_1	$B_{net,1}$ (mm)	$F_{n,1}$ (N)	$F_{z,t,k}$ (a) (N)	$F_{z,t,k}$ (b) (N)	$F_{z,t,k}$ (c) (N)	$R_{B,z,t,k}$ (kN)
angle bracket 70R	71304	70x70x55x2,0	71,0	36,5	21,0	2	1632	34,0	2	1632	9,5	2	35	1632	4734	1713	4896	4,73
angle bracket 105R	71305	105x105x90x2,0	104,0	76,0	15,8	4	3264	51,3	2	1632	6,3	2	80	1632	6925	3676	6528	6,53
angle bracket 120R	71306	120x120x90x2,5	118,8	76,3	15,5	4	3264	51,0	2	1632	5,8	2	80	1632	7193	3943	6528	6,53
angle bracket 140R	71307	140x140x90x2,5	138,8	76,3	15,5	4	3264	51,0	2	1632	5,8	2	80	1632	6990	3943	6528	6,53
angle bracket 90R	71308	90x90x65x2,0	89,0	55,0	15,5	2	1632	51,0	2	1632	13,0	2	55	1632	4603	2029	4896	4,60
angle bracket 90/90R	71311	90x90x90x2,5	88,8	76,3	15,5	4	3264	51,0	2	1632	6,0	0	80	0	7751	3946	4896	4,90
angle bracket 90R	71340	90x90x65x2,0	89,0	55,0	14,0	2	1632	37,0	2	1632	6,0	2	55	1632	5039	2302	4896	4,90
angle bracket 90R/2,5 A4	71460	90x90x65x2,5	88,8	45,0	15,3	2	1632				5,8	2	55	1632	3673	1945	3264	3,26
angle bracket 70R A4	71465	70x70x55x2,5	71,3	36,3	21,3	2	1632	34,3	2	1632	10,0	2	35	1632	4985	1967	4896	4,90
angle bracket 90R/2,0 A4	71468	90x90x65x2,0	89,0	55,0	15,5	2	1632	51,0	2	1632	13,0	2	55	1632	4632	2050	4896	4,63
angle bracket 105R/2,5 A4	71469	105x105x90x2,5	103,8	65,0	15,5	4	3264	51,0	2	1632	17,0	2	80	1632	6618	3969	6528	6,53
facade corner 150/90	71551	150x90x65x2,5	88,8	71,3	45,8	2	1632	63,8	2	1632	7,5	0	44	0	4768	1447	3264	3,26
facade corner 170/90	71552	170x90x65x2,5	88,8	71,3	45,8	2	1632	63,8	2	1632	7,5	0	44	0	4768	1448	3264	3,26
facade corner 190/90	71553	190x90x65x2,5	88,8	71,3	45,8	2	1632	63,8	2	1632	7,5	0	44	0	4768	1448	3264	3,26
facade corner 150/150	71554	150x150x65x2,5	148,8	71,3	45,8	2	1632	63,8	2	1632	7,5	2	44	1632	5063	1448	4896	4,90
facade corner 170/170	71555	170x170x65x2,5	168,8	71,3	45,8	2	1632	63,8	2	1632	7,5	2	44	1632	5030	1448	4896	4,90
facade corner 190/190	71556	190x190x65x2,5	188,8	71,3	45,8	2	1632	63,8	2	1632	7,5	2	44	1632	5008	1448	4896	4,90
angle bracket type 90/40/2,5R	73605	90x90x40x2,5	88,8	9,0							8,8	2	30	1632	1611	1293	1632	1,61
angle bracket type 40/140/2,5R	73606	140x40x40x2,5	40,3	9,0							0,3	2	30	1632	2239	2480	1632	2,24
angle bracket 50R	73609	50x50x55x2,5	48,8	9,0							4,8	2	45	1632	1998	2384	1632	2,00
angle bracket 65R	73610	65x65x55x2,0	64,0	9,0							5,0	2	55	1632	1713	1609	1632	1,63
angle bracket 40/50/2R	73612	50x50x40x2,0	49,0	9,0							9,0	2	30	1632	1413	796	1632	1,41
angle bracket 40/50/2,5R	73622	50x50x40x2,5	48,8	9,0							8,8	2	30	1632	1592	1293	1632	1,59
angle bracket 65/3R	73623	65x65x55x3,0	63,5	9,0							4,5	2	45	1632	2130	3527	1632	2,13
angle bracket 65/2,5R	73624	65x65x55x2,5	63,8	9,0							4,8	2	45	1632	1902	2384	1632	1,90

Table A2.6. continued

For stiffened connectors of 73600 –series, resistances also according to equation (12) with reduced flange length LB (= from rib to flange end):

Product type name	Art. No.	Size (mm)	L_B (mm)	d_1 (mm)	n_1	$B_{net,1}$ (mm)	$F_{n,1}$ (N)	d_2 (mm)	n_2	$B_{net,2}$ (mm)	$F_{n,2}$ (N)	$F_{z,t,k}$ (a) (N)	$F_{z,t,k}$ (b) (N)	$F_{z,t,k}$ (c) (N)	$F_{z,t,k}$ (d) (N)	$R_{B,z,t,k}$ (kN)
angle bracket type 90/40/2,5R	73605	90x90x40x2,5	79,75	8,75	2	30	1632	32,75	2	30	1632	2412	2622	1897	3264	1,90
angle bracket type 40/140/2,5R	73606	140x40x40x2,5	31,25	0,25	2	30	1632	24,25	0	30	0	2071	91772	2561	1632	2,07
angle bracket 50R	73609	50x50x55x2,5	39,75	4,75	2	45	1632	30,75	0	45	0	1912	6900	2446	1632	1,91
angle bracket 65R	73610	65x65x55x2,0	55	5	2	55	1632	31	2	45	1632	2254	4505	2029	3264	2,03
angle bracket 40/50/2R	73612	50x50x40x2,0	40	9	2	30	1632	33	0	30	0	1459	1593	1621	1632	1,46
angle bracket 40/50/2,5R	73622	50x50x40x2,5	39,75	8,75	2	30	1632	32,75	0	30	0	1601	2622	1897	1632	1,60
angle bracket 65/3R	73623	65x65x55x3,0	54,5	4,5	2	45	1632	30,5	2	45	1632	2599	10580	2952	3264	2,60
angle bracket 65/2,5R	73624	65x65x55x2,5	54,75	4,75	2	45	1632	30,75	2	45	1632	2410	6900	2446	3264	2,41